

SCREW - LOCK ASSEMBLY — STYLE 1

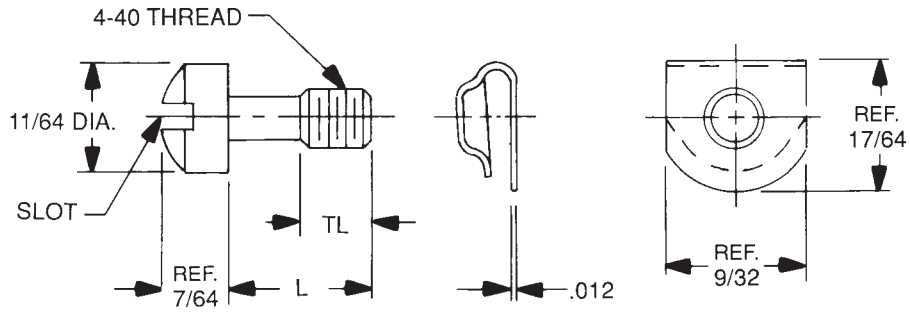

- Supplied with clip
- Supplied unassembled
- Supplied bulk packaged
- Screw locks mate with Jack Screws. See page 117
- See page 9 for finish codes

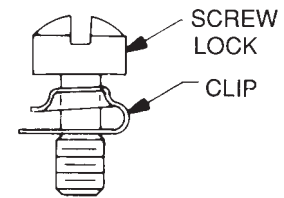

ASSEMBLY

Available with thread locking products, see page vii

Part No.	L Reference	TL Reference
4761	.200	.100
4762	.250	.125
4763	.281	.156
4764	.312	.156
4765	.375	.156
4766	.437	.156
4767	.500	.156
4768	.562	.156
4769	.625	.156
4770	.687	.156
4771	.750	.156

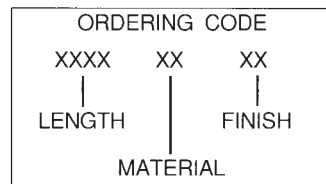

MATERIAL	CODE	RoHS
Steel	S	YES
Stainless Steel	SS	YES

SCREW - LOCK ASSEMBLY — STYLE 3

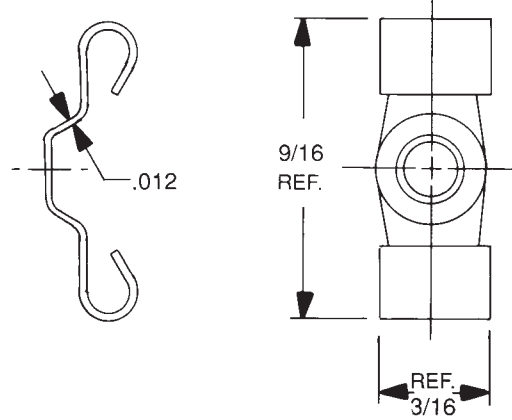
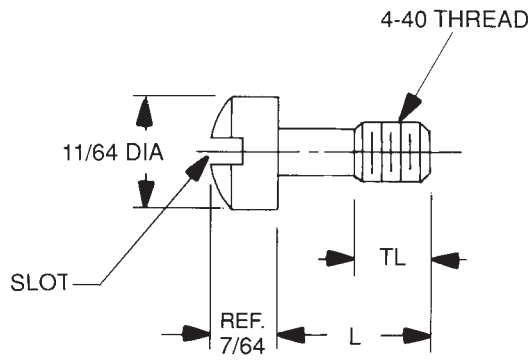

- Supplied with bow tie clip
- Supplied unassembled
- Supplied bulk packaged
- Screw locks mate with Jack Screws. See page 117
- Other material available - contact sales office
- See page 9 for finish codes

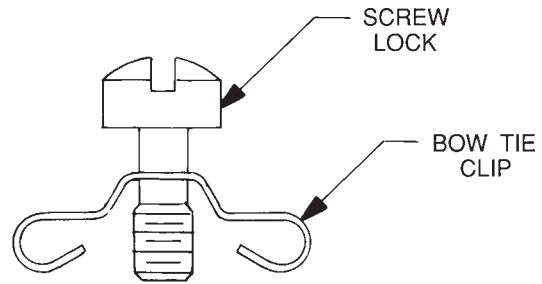

ASSEMBLY

Available with thread locking products, see page vii

Part No.	L Reference	TL Reference
4783	.200	.100
4784	.250	.125
4785	.281	.156
4786	.312	.156
4787	.375	.156
4788	.437	.156
4789	.500	.156
4790	.562	.156
4791	.625	.156
4792	.687	.156
4793	.750	.156

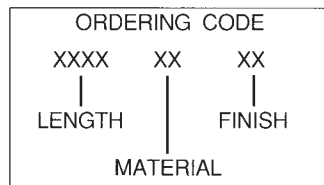

MATERIAL	CODE	RoHS
Steel	S	YES

MATERIALS

MATERIAL ROD & BAR	ORDERING CODE	MATERIAL SPECIFICATIONS	RoHS COMPLIANT
Aluminum	AL	QQ-A-225/3D, QQ-A-225/6A, QQ-A-225/8B, QQ-A-200/9D	YES
Brass	B	ASTM-B-16	YES
Nylon	N	LP-410A, D 4066	YES
Phenolic – Paper	PH	MIL-P-79 Type PBE, MIL-I-24768/10	YES
Phenolic – Linen	PHL	MIL-P-79 Type FBE, MIL-I-24768/13	YES
Steel	S	ASTM-A108-07	YES
Stainless Steel	SS	ASTM-A-581, A-582	YES
Teflon	TE	ASTM-1710	YES
Delrin	D	ASTM-D-4181	YES

* Non RoHS Compliant Finish

FINISH CODES

* 1	Cadmium (Commercial) (Special Order Only)	25	Black Oxide, Brass MIL-F-495E
* 2	Cadmium QQ-P-416F-Class 2 Type-1 (Clear Chromate) (Special Order Only)	26	Black Oxide, Stainless Steel, Steel Mil-DTL-13924D, Class 1 and 4
* 3	Cadmium QQ-P-416F-Class 2 Type-2 (Yellow Chromate) (Special Order Only)	27	Electro Tin Solder (60/40) per M222-MIL-F-14072D
4	Chrome Over Nickel	28	Zinc Plate .0002 ASTM-B-633 (Yellow Chromate)
5	Nickel QQ-N-290 Class 1 Grade G	29	Brushed Finish – Handles Only
* 6	Iridite #14 (Gold) MIL-DTL-5541F	30	Brushed Finish – Clear Lacquer – Handles Only
7	Iridite (Clear) MIL-DTL-5541F	31	Brushed Satin – Handles Only
* 9	Alodine 1200	32	Brushed Satin – Clear Anodize – Handles Only
10	Chrome QQ-C-320B Class 1 Type I (Bright Finish)	33	Brushed Satin – Black Anodize – Handles Only
11	Chrome QQ-C-320B Class 1 Type II (Satin Finish)	34	Satin Finish – Clear Anodize
12	Zinc .0002 ASTM-B-633 (Clear Chromate)	35	Satin Finish – Black Anodize
13	Bright Dip – Brass	36	Anodize MIL-A-8625F Black High Luster
14	Bright Tin ASTM B545 over Copper Flash Mil-C-14550	37	Ductile Nickel
15	Hot Tin Dip MIL-T-10727C Type II	38	Polished Nickel – Handles Only
16	Electro Tin ASTM B545 Class A, B or C	39	Caustic Etch and Lacquer
19	Caustic Etch	40	Semi-Frost Anodize (Clear)
20	Passivate MIL-F-14072E	41	Semi-Frost Anodize (Black)
21	Anodize MIL-A-8625F – Type II Class 2 (Sulfuric) Chemical Seal (Dark Grey)	42	Black Zinc
22	Anodize MIL-A-8625F – Type II Class 1 (Sulfuric) Hot Water Seal (Clear)	43	Blue Zinc
23	Anodize MIL-A-8625F – Type II Class 2 (Sulfuric) Chemical Seal (Yellow Green)	44	Electro Tin with Nickel Undercoat Per Mil-T-10727C
24	Anodize MIL-A-8625F – Type II Class 2 (Sulfuric) Chemical Seal (Black)	45	Passivate QQ-P-35C Type VI
		46	Passivate ASTM A 967 Nitric 1
		47	Passivate ASTM A 380-96
		48	Passivate AMS 2700 Type 2

NOTES

Responsibility ends with customer inspection or 10 days after customer receives parts. No returns will be accepted without prior approval from factory in writing.

All parts are stocked in plain finish. Parts will be plated to customer specification.

The items in this catalog are designed and manufactured to be functional. Engineering evaluation and quality assurance evaluations should be accomplished with functionality as a prime criteria.

RAF reserves the right to change any specifications, tolerances and plating types, for any products listed in this REFERENCE MANUAL without prior notice, provided the function of the item is not changed.

All custom (non-catalog) items are subject to an over shipment or under shipment of up to 10% of the order quantity. The price quotation from RAF will clearly identify these items.

The following processes make threaded fasteners of all sizes and configurations self-locking and self-sealing. They can be used with both male and female threads and leave fasteners fully adjustable. The ND Patches are *Automotive and Military Approved*.

ND PATCH®

Locking, Sealing, Reusable, Factory Pre-Applied

The ND Patch is completely dry, fused to the fastener, and requires no curing time after installation.

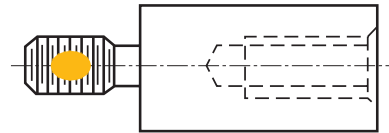

ND 360° RING-PATCH®

Locking, Sealing, Reusable, Factory Pre-Applied

The ND 360° Ring-Patch is completely dry, fused to the fastener, and requires no curing time after installation.

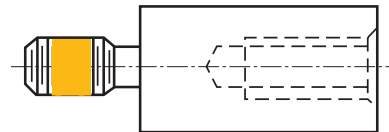

ND PELL-IT®

Locking, Sealing, Reusable, Factory Pre-Applied

The ND Pell-It is a special, tough nylon plug that is inserted into a drilled hole and makes any threaded fastener self-locking and self-sealing while leaving it fully adjustable. In addition to nylon, ND Pell-It is also available in KEL-F® and Vespel® for extremely high temperature applications.

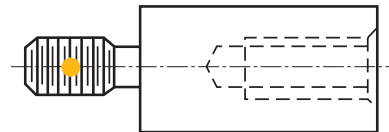

Two additional thread-locking products for your design needs:

ND MICROSPHERES®

Locking, Sealing, Bonding, Factory Pre-Applied

The micro-encapsulated adhesive market is no longer dominated by makers of expensive brand name products. ND Microspheres is an affordable, equivalent-quality alternative to brand name micro-encapsulated adhesives. It is offered in epoxy formulation, and is available *Pre-Applied*.

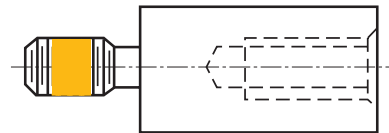

ND VIBRA-TITE®

Locking, Sealing, Re-Usable, Factory Pre-Applied, Minimizes Galling/Stripping

This low-cost blend of acrylic resins makes any threaded fastener self-locking and self-sealing, preventing it from loosening even under extreme vibration. Vibra-tite is available factory *Pre-Applied*. Once coated, the parts can be stored indefinitely before use. In addition, ND Vibra-tite is *Military Approved*.

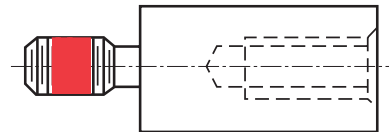

ND®, ND Patch®, ND 360° Ring-Patch®, ND Pell-It®, ND Microspheres®, and ND Vibra-tite® are all registered trademarks of ND Industries, Inc.

Thread-locking products can be added to:

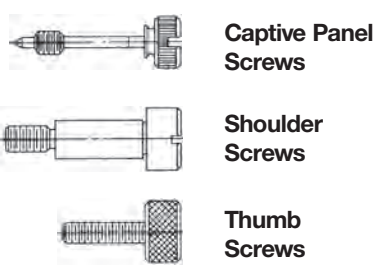
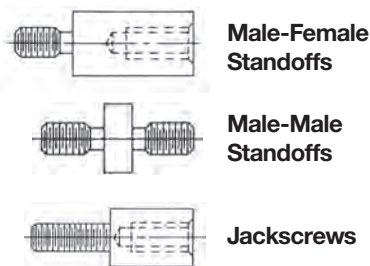

How to order

Just add the appropriate thread-locking designation to our product number. Here's an example of ND PATCH added to a hex male-female standoff number:

4500-440-SS-PL

Thread-locking product designations

ND PATCH	PL
ND 360° RING PATCH	RP
ND PELL-IT	PI
ND MICROSPHERES	MS
ND VIBRA-TITE	VT



3/16 HEX JACK SCREWS

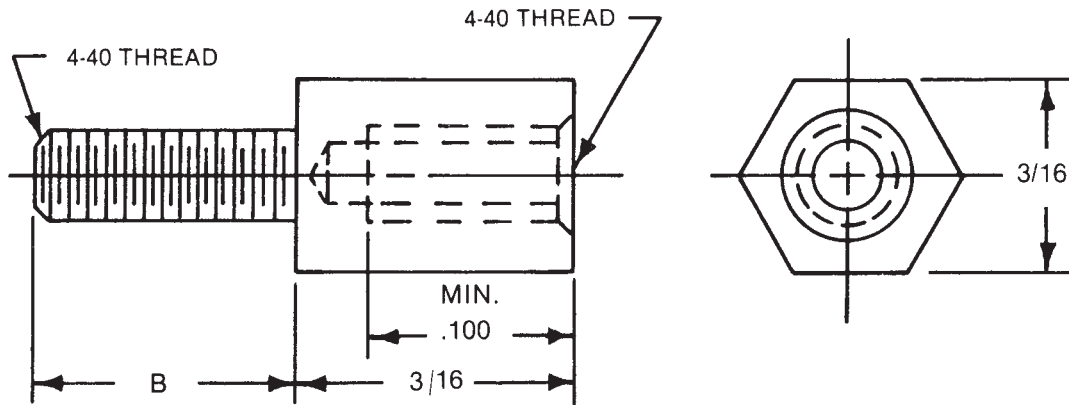

Available with thread locking products, see page vii

SUPPLIED WITH

- TWO (2) #4 FLAT WASHERS
- ONE (1) #4 LOCK WASHER
- ONE (1) #4-40 NUT

SUPPLIED UNASSEMBLED

(RoHS Compliant)

MATERIAL

STEEL ASTM-108

FINISH

ZINC PLATE PER ASTM-B-633
(YELLOW CHROMATE)

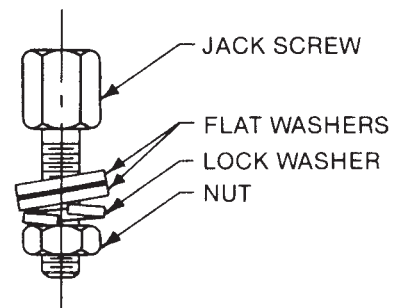

ASSEMBLY

B	PART NUMBER	RoHS
3/16	4750-1	YES
1/4	4750-2	YES
5/16	4750-3	YES
3/8	4750-4	YES
7/16	4750-5	YES
1/2	4750-6	YES
9/16	4750-7	YES
5/8	4750-8	YES
11/16	4750-9	YES
3/4	4750-10	YES

