

1/4 ROUND – 180° 3 POSITION – EXTERNAL THREAD HANDLES

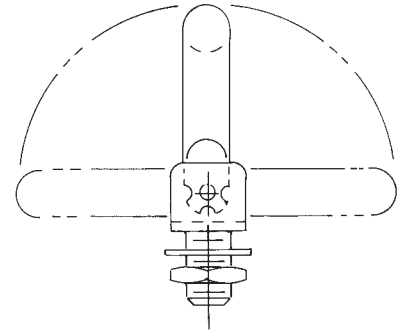

Nuts and washers supplied
 See page 4H for finish codes
 For non-standard parts contact Sales Office

PART NO.	L ±1/32	H ±1/32
8758	4"	1.430
8759	4-1/4"	
8760	4-1/2"	
8761	5"	
8762	6"	
8763	7"	
8764	3"	1.460
8765	3-1/2"	
8766	4"	
8767	4-1/4"	
8768	5"	
8769	6"	

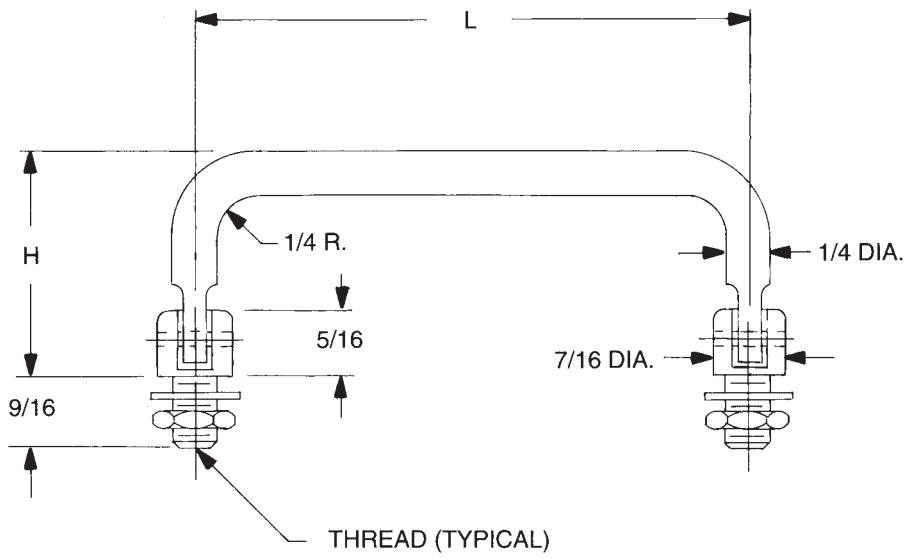
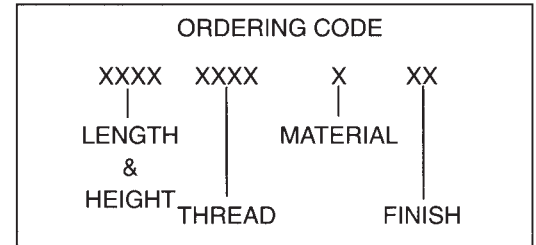

THREAD CODE	
THREAD	CODE
1/4-28	2528
5/16-24	3124

MATERIAL	CODE	RoHS
Aluminum	A	YES
Brass	B	YES
Stainless Steel	SS	YES
Steel	S	YES



5/16 ROUND – 180° 3 POSITION – EXTERNAL THREAD HANDLES

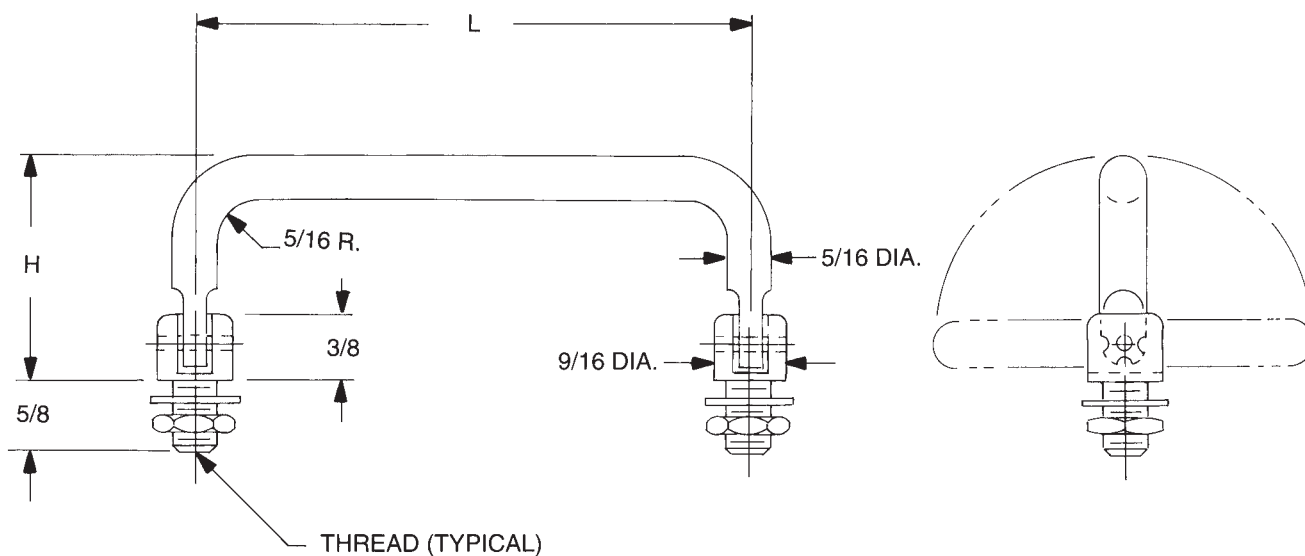

Nuts and washers supplied
 See page 4H for finish codes
 For non-standard parts contact Sales Office

PART NO.	L ±1/32	H ±1/32
8770	4"	1.430
8771	4-1/4"	
8772	4-1/2"	
8773	5"	
8774	6"	
8775	7"	
8776	3"	1.530
8777	3-1/2"	
8778	4"	
8779	4-1/4"	
8780	4-1/2"	
8781	5"	
8782	6"	
8783	3"	1.850
8784	3-1/2"	
8785	4"	
8786	4-1/4"	
8787	4-1/2"	
8788	5"	
8789	6"	

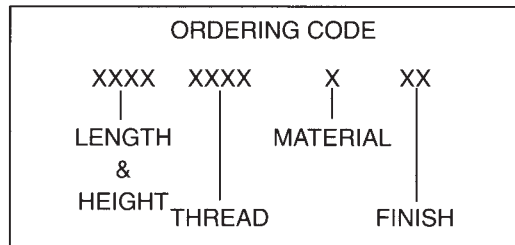

THREAD CODE	
THREAD	CODE
5/16-24	3124
3/8-24	3724

MATERIAL	CODE	RoHS
Aluminum	A	YES
Brass	B	YES
Stainless Steel	SS	YES
Steel	S	YES

3/8 ROUND – 180° 3 POSITION – EXTERNAL THREAD HANDLES

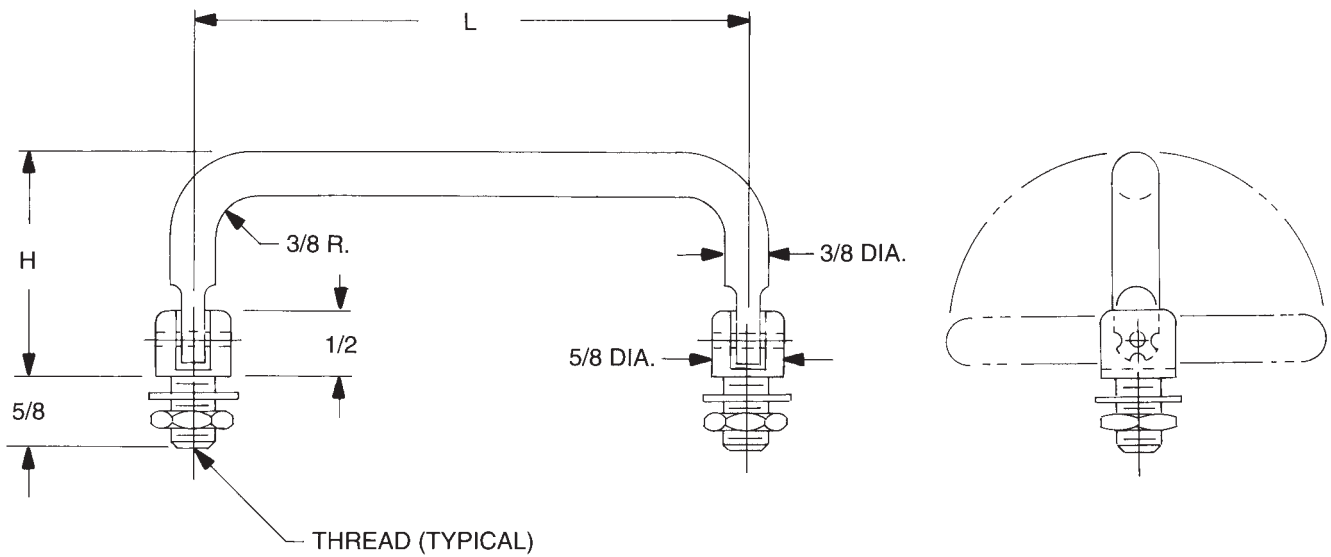

Nuts and washers supplied
 See page 4H for finish codes
 For non-standard parts contact Sales Office

PART NO.	L ±1/32	H ±1/32
8790	3"	
8791	3-1/2"	
8792	4"	
8793	4-1/4"	1.530
8794	4-1/2"	
8795	5"	
8796	6"	
8797	4"	1.810
8798	4-1/4"	
8799	4-1/2"	
8800	5"	
8801	6"	

PART NO.	L ±1/32	H ±1/32
8802	3"	
8803	3-1/2"	
8804	4"	
8805	4-1/4"	1.850
8806	4-1/2"	
8807	5"	
8808	6"	
8809	4"	2.375
8810	4-1/4"	
8811	4-1/2"	
8812	5"	

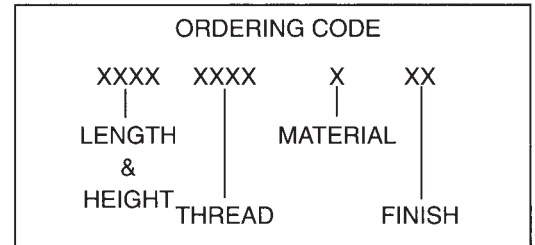

THREAD CODE	
THREAD	CODE
5/16-24	3124
3/8-24	3724

MATERIAL	CODE	RoHS
Aluminum	A	YES
Brass	B	YES
Stainless Steel	SS	YES
Steel	S	YES



MATERIALS

MATERIAL ROD & BAR	ORDERING CODE	MATERIAL SPECIFICATIONS	RoHS COMPLIANT
Aluminum	A	QQ-A-225/8B, QQ-A-200/9D	YES
Aluminum (Ferrules Only)	AL	QQ-A-225/3D, QQ-A-225/6A, QQ-A-225/8B, QQ-A-200/9D	YES
Brass	B	ASTM-B-16	YES
Steel	S	ASTM-A108-07	YES
Stainless Steel	SS	ASTM-A-581, A-582	YES

* Non RoHS Compliant Finish

FINISH CODES

*1	Cadmium (Commercial) (Special Order Only)	25	Black Oxide, Brass MIL-F-495E
*2	Cadmium QQ-P-416F-Class 2 (Special Order Only) Type-1 (Clear Chromate)	26	Black Oxide, Stainless Steel, Steel MIL-DTL-13924D, Class 1 and 4
*3	Cadmium QQ-P-416F-Class 2 (Special Order Only) Type-2 (Yellow Chromate)	28	Zinc Plate .0002 ASTM-B-633 (Yellow Chromate)
5	Nickel QQ-N-290 Class 1 Grade G	29	Brushed Finish – Handles Only
*6	Iridite #14 (Gold) MIL-DTL-5541F	30	Brushed Finish – Clear Lacquer – Handles Only
7	Iridite (Clear) MIL-DTL-5541F	31	Brushed Satin – Handles Only
*9	Alodine 1200	32	Brushed Satin – Clear Anodize – Handles Only
10	Chrome QQ-C-320B Class 1 Type I (Bright Finish)	33	Brushed Satin – Black Anodize – Handles Only
11	Chrome QQ-C-320B Class 1 Type II (Satin Finish)	34	Satin Finish – Clear Anodize
12	Zinc .0002 ASTM-B-633 (Clear Chromate)	35	Satin Finish – Black Anodize
19	Caustic Etch	36	Anodize MIL-A-8625F Black High Luster
20	Passivate MIL-F-14072E	38	Polished Nickel – Handles Only
21	Anodize MIL-A-8625F – Type II Class 2 (Sulfuric) Chemical Seal (Dark Grey)	39	Caustic Etch and Lacquer
22	Anodize MIL-A-8625F – Type II Class 1 (Sulfuric) Hot Water Seal (Clear)	40	Semi-Frost Anodize (Clear)
23	Anodize MIL-A-8625F – Type II Class 2 (Sulfuric) Chemical Seal (Yellow Green)	41	Semi-Frost Anodize (Black)
24	Anodize MIL-A-8625F – Type II Class 2 (Sulfuric) Chemical Seal (Black)	45	Passivate QQ-P-35C Type VI
		46	Passivate ASTM A 967 Nitric 1
		47	Passivate ASTM A 380-96
		48	Passivate AMS 2700 Type 2

DEPTHS OF THREADS

THREAD	BLIND TAP DEPTH
	ALUMINUM, BRASS ST. ST., STEEL
2-56	3/16
4-40	1/4
6-32	3/8
8-32	7/16
10-24	9/16
10-32	9/16
1/4-20	5/8
5/16-18	5/8
3/8-24	5/8

THREADS ARE TO COMMERCIAL 2A AND 2B STANDARDS PER HANDBOOK H-28 (PART I) SCREW THREAD STANDARDS (FEDERAL)

PERCENTAGE OF THREAD FOR TAPPED HOLES

TAP SIZE	FORM TAP	CUT TAP
2	55	65
4	55	65
6	55	65
8	55	65
10	55	65
1/4	55	65
5/16	60	70
3/8	60	70

THREADS ARE SUPPLIED CUT OR ROLLED AT OUR OPTION UNLESS SPECIFICALLY NOTED ON ORDER.