

# CAPTIVE PANEL HARDWARE

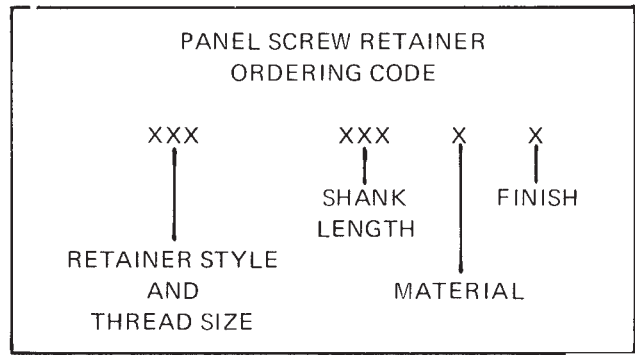
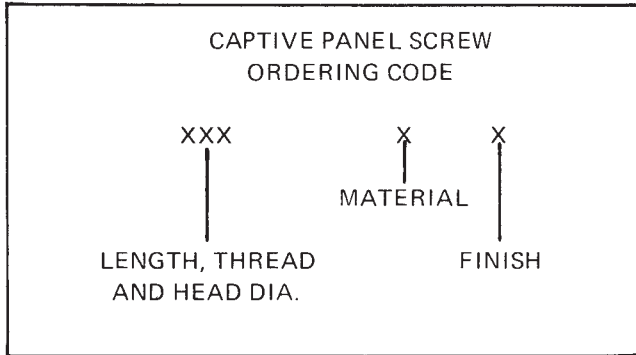

According to individual design any combination of captive panel screw and retainer may be used. Certain captive screws and retainers are more compatible. The following chart indicates the recommended combinations, but is intended as a guide only. The selection of captive panel screw and panel retainer is at the option of the buyer, as both items are purchased separately.

CAPTIVE SCREW	CAPTIVE SCREW RETAINER
Style 1	Style – B – C – D – E
Style 2	Style – A
Style 3	Style – F – G

MATERIAL	CODE	RoHS
Brass	B	Yes
Stainless Steel	SS	Yes
Steel	S	Yes

Any captive panel screw can be supplied without the slot. Indicate on purchase order after part number – unslotted.

The following are a few examples of screws that can be supplied to your specifications. There is no set pattern, dimensions and configurations can be determined using the examples as a guide.

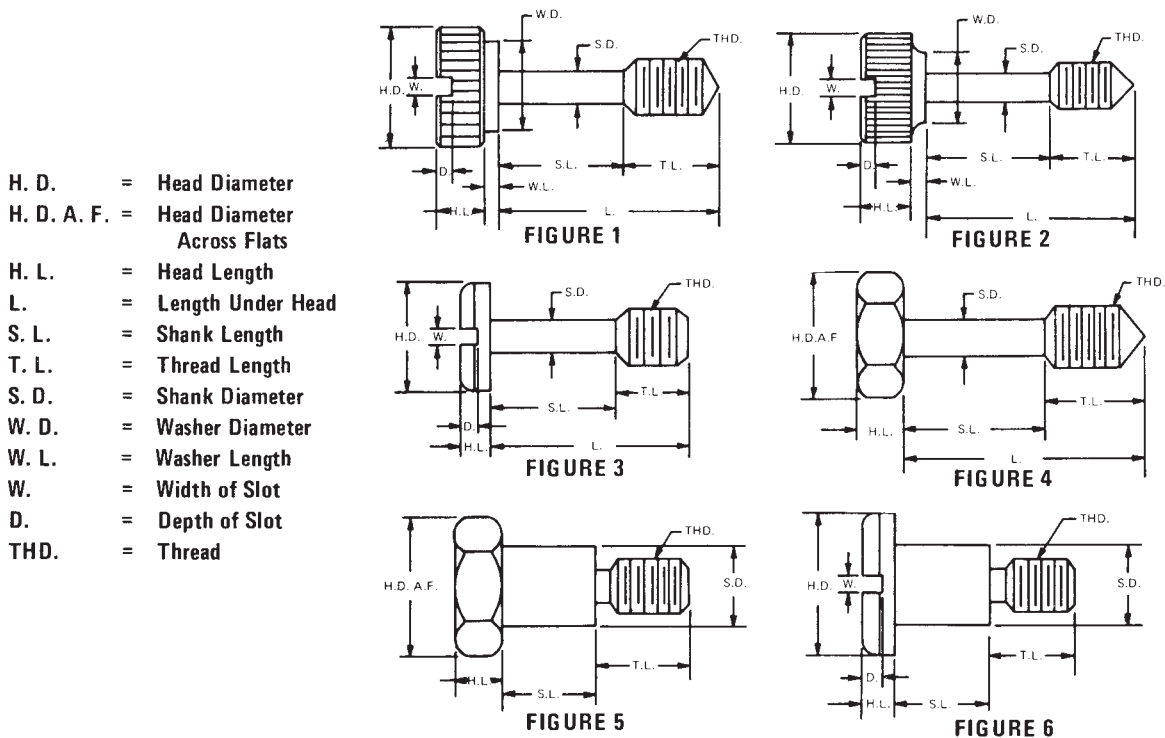

# CAPTIVE PANEL SCREW – STYLE 1

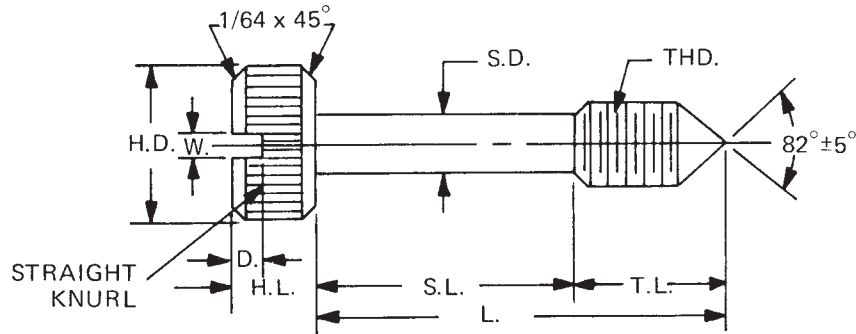

Available with thread locking products, see page vii

See page 11 for ordering code  
 See page 9 for finish codes  
 For non-standard parts contact Sales Office

PART NO.	THD.	H.D. +.015 -.000	H.L. ±.010	L. ±.015	T.L. ±.015	S.D. ±.005	S.L. ±.010	W. +.005 -.000	D. +.010 -.000	KNURL TPI
0100	4-40	5/16	3/16	21/32	9/32	.078	3/8	.036	1/16	35
0101	4-40	5/16	3/16	23/32	9/32	.078	7/16	.036	1/16	35
0102	4-40	5/16	3/16	25/32	9/32	.078	1/2	.036	1/16	35
0103	4-40	5/16	3/16	27/32	9/32	.078	9/16	.036	1/16	35
0104	4-40	5/16	3/16	29/32	9/32	.078	5/8	.036	1/16	35
0105	6-32	5/16	3/16	21/32	9/32	.095	3/8	.045	1/16	35
0106	6-32	5/16	3/16	23/32	9/32	.095	7/16	.045	1/16	35
0107	6-32	5/16	3/16	25/32	9/32	.095	1/2	.045	1/16	35
0108	6-32	5/16	3/16	27/32	9/32	.095	9/16	.045	1/16	35
0109	6-32	5/16	3/16	29/32	9/32	.095	5/8	.045	1/16	35
0110	6-32	3/8	3/16	21/32	9/32	.095	3/8	.045	1/16	30
0111	6-32	3/8	3/16	23/32	9/32	.095	7/16	.045	1/16	30
0112	6-32	3/8	3/16	25/32	9/32	.095	1/2	.045	1/16	30
0113	6-32	3/8	3/16	27/32	9/32	.095	9/16	.045	1/16	30
0114	6-32	3/8	3/16	29/32	9/32	.095	5/8	.045	1/16	30
0115	8-32	7/16	1/4	5/8	3/8	.120	1/4	1/16	1/16	30
0116	8-32	7/16	1/4	11/16	3/8	.120	5/16	1/16	1/16	30
0117	8-32	7/16	1/4	3/4	3/8	.120	3/8	1/16	1/16	30
0118	8-32	7/16	1/4	13/16	3/8	.120	7/16	1/16	1/16	30
0119	8-32	7/16	1/4	7/8	3/8	.120	1/2	1/16	1/16	30
0120	8-32	7/16	1/4	15/16	3/8	.120	9/16	1/16	1/16	30
0121	8-32	7/16	1/4	1"	3/8	.120	5/8	1/16	1/16	30
0122	8-32	7/16	1/4	1-1/16	3/8	.120	11/16	1/16	1/16	30
0123	8-32	7/16	1/4	1-1/8	3/8	.120	3/4	1/16	1/16	30
0124	8-32	7/16	1/4	1-3/16	3/8	.120	13/16	1/16	1/16	30
0125	8-32	7/16	1/4	1-1/4	3/8	.120	7/8	1/16	1/16	30
0126	8-32	7/16	1/4	1-5/16	3/8	.120	15/16	1/16	1/16	30
0127	8-32	7/16	1/4	1-3/8	3/8	.120	1"	1/16	1/16	30
0128	8-32	7/16	1/4	1-7/16	3/8	.120	1-1/16	1/16	1/16	30
0129	8-32	7/16	1/4	1-1/2	3/8	.120	1-1/8	1/16	1/16	30
0130	8-32	7/16	1/4	1-9/16	3/8	.120	1-3/16	1/16	1/16	30
0131	8-32	7/16	1/4	1-5/8	3/8	.120	1-1/4	1/16	1/16	30
0132	8-32	7/16	1/4	1-11/16	3/8	.120	1-5/16	1/16	1/16	30
0133	8-32	7/16	1/4	1-3/4	3/8	.120	1-3/8	1/16	1/16	30



# CAPTIVE PANEL SCREW – STYLE 1

See page 11 for ordering code  
 See page 9 for finish codes  
 For non-standard parts contact Sales Office

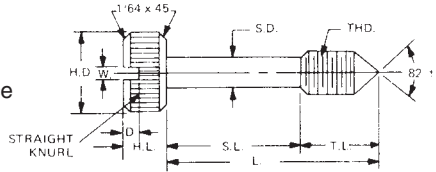

Available with thread locking products, see page vii

PART NO.	THD.	H.D. +.015 -.000	H.L. ±.010	L. ±.015	T.L. ±.015	S.D. ±.005	S.L. ±.010	W. +.005 -.000	D. +.010 -.000	KNURL TPI
0134	8-32	7/16	1/4	1-13/16	3/8	.120	1-7/16	1/16	1/16	30
0135	8-32	7/16	1/4	1-7/8	3/8	.120	1-1/2	1/16	1/16	30
0136	8-32	7/16	1/4	1-15/16	3/8	.120	1-9/16	1/16	1/16	30
0137	8-32	7/16	1/4	2"	3/8	.120	1-5/8	1/16	1/16	30
0138	10-24	7/16	1/4	5/8	3/8	.130	1/4	1/16	1/16	30
0139	10-24	7/16	1/4	11/16	3/8	.130	5/16	1/16	1/16	30
0140	10-24	7/16	1/4	3/4	3/8	.130	3/8	1/16	1/16	30
0141	10-24	7/16	1/4	13/16	3/8	.130	7/16	1/16	1/16	30
0142	10-24	7/16	1/4	7/8	3/8	.130	1/2	1/16	1/16	30
0143	10-24	7/16	1/4	15/16	3/8	.130	9/16	1/16	1/16	30
0144	10-24	7/16	1/4	1"	3/8	.130	5/8	1/16	1/16	30
0145	10-24	7/16	1/4	1-1/16	3/8	.130	11/16	1/16	1/16	30
0146	10-24	7/16	1/4	1-1/8	3/8	.130	3/4	1/16	1/16	30
0147	10-24	7/16	1/4	1-3/16	3/8	.130	13/16	1/16	1/16	30
0148	10-24	7/16	1/4	1-1/4	3/8	.130	7/8	1/16	1/16	30
0149	10-24	7/16	1/4	1-5/16	3/8	.130	15/16	1/16	1/16	30
0150	10-24	7/16	1/4	1-3/8	3/8	.130	1"	1/16	1/16	30
0151	10-24	7/16	1/4	1-7/16	3/8	.130	1-1/16	1/16	1/16	30
0152	10-24	7/16	1/4	1-1/2	3/8	.130	1-1/8	1/16	1/16	30
0153	10-24	7/16	1/4	1-9/16	3/8	.130	1-3/16	1/16	1/16	30
0154	10-24	7/16	1/4	1-5/8	3/8	.130	1-1/4	1/16	1/16	30
0155	10-24	7/16	1/4	1-11/16	3/8	.130	1-5/16	1/16	1/16	30
0156	10-24	7/16	1/4	1-3/4	3/8	.130	1-3/8	1/16	1/16	30
0157	10-24	7/16	1/4	1-13/16	3/8	.130	1-7/16	1/16	1/16	30
0158	10-24	7/16	1/4	1-7/8	3/8	.130	1-1/2	1/16	1/16	30
0159	10-24	7/16	1/4	1-15/16	3/8	.130	1-9/16	1/16	1/16	30
0160	10-24	7/16	1/4	2"	3/8	.130	1-5/8	1/16	1/16	30
0161	10-32	7/16	1/4	5/8	3/8	.130	1/4	1/16	1/16	30
0162	10-32	7/16	1/4	11/16	3/8	.130	5/16	1/16	1/16	30
0163	10-32	7/16	1/4	3/4	3/8	.130	3/8	1/16	1/16	30
0164	10-32	7/16	1/4	13/16	3/8	.130	7/16	1/16	1/16	30
0165	10-32	7/16	1/4	7/8	3/8	.130	1/2	1/16	1/16	30
0166	10-32	7/16	1/4	15/16	3/8	.130	9/16	1/16	1/16	30
0167	10-32	7/16	1/4	1"	3/8	.130	5/8	1/16	1/16	30
0168	10-32	7/16	1/4	1-1/16	3/8	.130	11/16	1/16	1/16	30
0169	10-32	7/16	1/4	1-1/8	3/8	.130	3/4	1/16	1/16	30
0170	10-32	7/16	1/4	1-3/16	3/8	.130	13/16	1/16	1/16	30
0171	10-32	7/16	1/4	1-1/4	3/8	.130	7/8	1/16	1/16	30
0172	10-32	7/16	1/4	1-5/16	3/8	.130	15/16	1/16	1/16	30
0173	10-32	7/16	1/4	1-3/8	3/8	.130	1"	1/16	1/16	30
0174	10-32	7/16	1/4	1-7/16	3/8	.130	1-1/16	1/16	1/16	30
0175	10-32	7/16	1/4	1-1/2	3/8	.130	1-1/8	1/16	1/16	30
0176	10-32	7/16	1/4	1-9/16	3/8	.130	1-3/16	1/16	1/16	30
0177	10-32	7/16	1/4	1-5/8	3/8	.130	1-1/4	1/16	1/16	30
0178	10-32	7/16	1/4	1-11/16	3/8	.130	1-5/16	1/16	1/16	30
0179	10-32	7/16	1/4	1-3/4	3/8	.130	1-3/8	1/16	1/16	30



# CAPTIVE PANEL SCREW – STYLE 1

See page 11 for ordering code  
 See page 9 for finish codes  
 For non-standard parts contact Sales Office

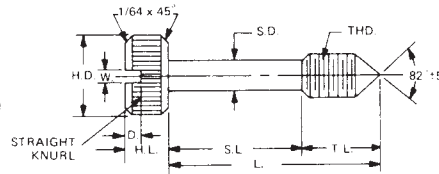

Available with thread locking products, see page vii

PART NO.	THD.	H.D. +.015 -.000	H.L. ±.010	L. ±.015	T.L. ±.015	S.D. ±.005	S.L. ±.010	W. +.005 -.000	D. +.010 -.000	KNURL TPI
0180	10-32	7/16	1/4	1-13/16	3/8	.130	1-7/16	1/16	1/16	30
0181	10-32	7/16	1/4	1-7/8	3/8	.130	1-1/2	1/16	1/16	30
0182	10-32	7/16	1/4	1-15/16	3/8	.130	1-9/16	1/16	1/16	30
0183	10-32	7/16	1/4	2"	3/8	.130	1-5/8	1/16	1/16	30
0184	12-24	9/16	1/4	5/8	3/8	.150	1/4	1/16	3/32	30
0185	12-24	9/16	1/4	11/16	3/8	.150	5/16	1/16	3/32	30
0186	12-24	9/16	1/4	3/4	3/8	.150	3/8	1/16	3/32	30
0187	12-24	9/16	1/4	13/16	3/8	.150	7/16	1/16	3/32	30
0188	12-24	9/16	1/4	7/8	3/8	.150	1/2	1/16	3/32	30
0189	12-24	9/16	1/4	15/16	3/8	.150	9/16	1/16	3/32	30
0190	12-24	9/16	1/4	1"	3/8	.150	5/8	1/16	3/32	30
0191	12-24	9/16	1/4	1-1/16	3/8	.150	11/16	1/16	3/32	30
0192	12-24	9/16	1/4	1-1/8	3/8	.150	3/4	1/16	3/32	30
0193	12-24	9/16	1/4	1-3/16	3/8	.150	13/16	1/16	3/32	30
0194	12-24	9/16	1/4	1-1/4	3/8	.150	7/8	1/16	3/32	30
0195	12-24	9/16	1/4	1-5/16	3/8	.150	15/16	1/16	3/32	30
0196	12-24	9/16	1/4	1-3/8	3/8	.150	1"	1/16	3/32	30
0197	12-24	9/16	1/4	1-7/16	3/8	.150	1-1/16	1/16	3/32	30
0198	12-24	9/16	1/4	1-1/2	3/8	.150	1-1/8	1/16	3/32	30
0199	12-24	9/16	1/4	1-9/16	3/8	.150	1-3/16	1/16	3/32	30
0200	12-24	9/16	1/4	1-5/8	3/8	.150	1-1/4	1/16	3/32	30
0201	12-24	9/16	1/4	1-11/16	3/8	.150	1-5/16	1/16	3/32	30
0202	12-24	9/16	1/4	1-3/4	3/8	.150	1-3/8	1/16	3/32	30
0203	12-24	9/16	1/4	1-13/16	3/8	.150	1-7/16	1/16	3/32	30
0204	12-24	9/16	1/4	1-7/8	3/8	.150	1-1/2	1/16	3/32	30
0205	12-24	9/16	1/4	1-15/16	3/8	.150	1-9/16	1/16	3/32	30
0206	12-24	9/16	1/4	2"	3/8	.150	1-5/8	1/16	3/32	30
0207	1/4-20	9/16	1/4	5/8	3/8	.175	1/4	1/16	3/32	30
0208	1/4-20	9/16	1/4	11/16	3/8	.175	5/16	1/16	3/32	30
0209	1/4-20	9/16	1/4	3/4	3/8	.175	3/8	1/16	3/32	30
0210	1/4-20	9/16	1/4	13/16	3/8	.175	7/16	1/16	3/32	30
0211	1/4-20	9/16	1/4	7/8	3/8	.175	1/2	1/16	3/32	30
0212	1/4-20	9/16	1/4	15/16	3/8	.175	9/16	1/16	3/32	30
0213	1/4-20	9/16	1/4	1"	3/8	.175	5/8	1/16	3/32	30
0214	1/4-20	9/16	1/4	1-1/16	3/8	.175	11/16	1/16	3/32	30
0215	1/4-20	9/16	1/4	1-1/8	3/8	.175	3/4	1/16	3/32	30
0216	1/4-20	9/16	1/4	1-3/16	3/8	.175	13/16	1/16	3/32	30
0217	1/4-20	9/16	1/4	1-1/4	3/8	.175	7/8	1/16	3/32	30
0218	1/4-20	9/16	1/4	1-5/16	3/8	.175	15/16	1/16	3/32	30
0219	1/4-20	9/16	1/4	1-3/8	3/8	.175	1"	1/16	3/32	30
0220	1/4-20	9/16	1/4	1-7/16	3/8	.175	1-1/16	1/16	3/32	30
0221	1/4-20	9/16	1/4	1-1/2	3/8	.175	1-1/8	1/16	3/32	30
0222	1/4-20	9/16	1/4	1-9/16	3/8	.175	1-3/16	1/16	3/32	30
0223	1/4-20	9/16	1/4	1-5/8	3/8	.175	1-1/4	1/16	3/32	30
0224	1/4-20	9/16	1/4	1-11/16	3/8	.175	1-5/16	1/16	3/32	30
0225	1/4-20	9/16	1/4	1-3/4	3/8	.175	1-3/8	1/16	3/32	30



# CAPTIVE PANEL SCREW – STYLE 1

See page 11 for ordering code  
 See page 9 for finish codes  
 For non-standard parts contact Sales Office

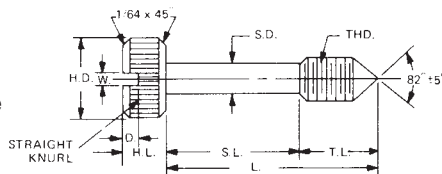

Available with thread locking products, see page vii

PART NO.	THD.	H.D. +.015 -.000	H.L. ±.010	L. ±.015	T.L. ±.015	S.D. ±.005	S.L. ±.010	W. +.005 -.000	D. +.010 -.000	KNURL TPI
0226	1/4-20	9/16	1/4	1-13/16	3/8	.175	1-7/16	1/16	3/32	30
0227	1/4-20	9/16	1/4	1-7/8	3/8	.175	1-1/2	1/16	3/32	30
0228	1/4-20	9/16	1/4	1-15/16	3/8	.175	1-9/16	1/16	3/32	30
0229	1/4-20	9/16	1/4	2"	3/8	.175	1-5/8	1/16	3/32	30
0230	1/4-20	3/4	1/4	5/8	3/8	.175	1/4	1/16	1/8	30
0231	1/4-20	3/4	1/4	11/16	3/8	.175	5/16	1/16	1/8	30
0232	1/4-20	3/4	1/4	3/4	3/8	.175	3/8	1/16	1/8	30
0233	1/4-20	3/4	1/4	13/16	3/8	.175	7/16	1/16	1/8	30
0234	1/4-20	3/4	1/4	7/8	3/8	.175	1/2	1/16	1/8	30
0235	1/4-20	3/4	1/4	15/16	3/8	.175	9/16	1/16	1/8	30
0236	1/4-20	3/4	1/4	1"	3/8	.175	5/8	1/16	1/8	30
0237	1/4-20	3/4	1/4	1-1/16	3/8	.175	11/16	1/16	1/8	30
0238	1/4-20	3/4	1/4	1-1/8	3/8	.175	3/4	1/16	1/8	30
0239	1/4-20	3/4	1/4	1-3/16	3/8	.175	13/16	1/16	1/8	30
0240	1/4-20	3/4	1/4	1-1/4	3/8	.175	7/8	1/16	1/8	30
0241	1/4-20	3/4	1/4	1-5/16	3/8	.175	15/16	1/16	1/8	30
0242	1/4-20	3/4	1/4	1-3/8	3/8	.175	1"	1/16	1/8	30
0243	1/4-20	3/4	1/4	1-7/16	3/8	.175	1-1/16	1/16	1/8	30
0244	1/4-20	3/4	1/4	1-1/2	3/8	.175	1-1/8	1/16	1/8	30
0245	1/4-20	3/4	1/4	1-9/16	3/8	.175	1-3/16	1/16	1/8	30
0246	1/4-20	3/4	1/4	1-5/8	3/8	.175	1-1/4	1/16	1/8	30
0247	1/4-20	3/4	1/4	1-11/16	3/8	.175	1-5/16	1/16	1/8	30
0248	1/4-20	3/4	1/4	1-3/4	3/8	.175	1-3/8	1/16	1/8	30
0249	1/4-20	3/4	1/4	1-13/16	3/8	.175	1-7/16	1/16	1/8	30
0250	1/4-20	3/4	1/4	1-7/8	3/8	.175	1-1/2	1/16	1/8	30
0251	1/4-20	3/4	1/4	1-15/16	3/8	.175	1-9/16	1/16	1/8	30
0252	1/4-20	3/4	1/4	2"	3/8	.175	1-5/8	1/16	1/8	30
0253	1/4-28	9/16	1/4	5/8	3/8	.175	1/4	1/16	3/32	30
0254	1/4-28	9/16	1/4	11/16	3/8	.175	5/16	1/16	3/32	30
0255	1/4-28	9/16	1/4	3/4	3/8	.175	3/8	1/16	3/32	30
0256	1/4-28	9/16	1/4	13/16	3/8	.175	7/16	1/16	3/32	30
0257	1/4-28	9/16	1/4	7/8	3/8	.175	1/2	1/16	3/32	30
0258	1/4-28	9/16	1/4	15/16	3/8	.175	9/16	1/16	3/32	30
0259	1/4-28	9/16	1/4	1"	3/8	.175	5/8	1/16	3/32	30
0260	1/4-28	9/16	1/4	1-1/16	3/8	.175	11/16	1/16	3/32	30
0261	1/4-28	9/16	1/4	1-1/8	3/8	.175	3/4	1/16	3/32	30
0262	1/4-28	9/16	1/4	1-3/16	3/8	.175	13/16	1/16	3/32	30
0263	1/4-28	9/16	1/4	1-1/4	3/8	.175	7/8	1/16	3/32	30
0264	1/4-28	9/16	1/4	1-5/16	3/8	.175	15/16	1/16	3/32	30
0265	1/4-28	9/16	1/4	1-3/8	3/8	.175	1"	1/16	3/32	30
0266	1/4-28	9/16	1/4	1-7/16	3/8	.175	1-1/16	1/16	3/32	30
0267	1/4-28	9/16	1/4	1-1/2	3/8	.175	1-1/8	1/16	3/32	30
0268	1/4-28	9/16	1/4	1-9/16	3/8	.175	1-3/16	1/16	3/32	30
0269	1/4-28	9/16	1/4	1-5/8	3/8	.175	1-1/4	1/16	3/32	30
0270	1/4-28	9/16	1/4	1-11/16	3/8	.175	1-5/16	1/16	3/32	30
0271	1/4-28	9/16	1/4	1-3/4	3/8	.175	1-3/8	1/16	3/32	30



# CAPTIVE PANEL SCREW – STYLE 1

See page 11 for ordering code  
 See page 9 for finish codes  
 For non-standard parts contact Sales Office

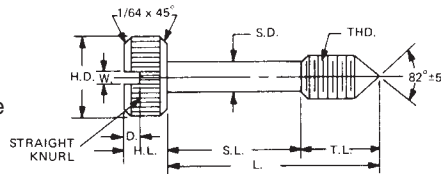

Available with thread locking products, see page vii

PART NO.	THD.	H.D. +.015 -.000	H.L. ±.010	L. ±.015	T.L. ±.015	S.D. ±.005	S.L. ±.010	W. +.005 -.000	D. +.010 -.000	KNURL TPI
0272	1/4-28	9/16	1/4	1-13/16	3/8	.175	1-7/16	1/16	3/32	30
0273	1/4-28	9/16	1/4	1-7/8	3/8	.175	1-1/2	1/16	3/32	30
0274	1/4-28	9/16	1/4	1-15/16	3/8	.175	1-9/16	1/16	3/32	30
0275	1/4-28	9/16	1/4	2"	3/8	.175	1-5/8	1/16	3/32	30
0276	1/4-28	3/4	1/4	5/8	3/8	.175	1/4	1/16	1/8	30
0277	1/4-28	3/4	1/4	11/16	3/8	.175	5/16	1/16	1/8	30
0278	1/4-28	3/4	1/4	3/4	3/8	.175	3/8	1/16	1/8	30
0279	1/4-28	3/4	1/4	13/16	3/8	.175	7/16	1/16	1/8	30
0280	1/4-28	3/4	1/4	7/8	3/8	.175	1/2	1/16	1/8	30
0281	1/4-28	3/4	1/4	15/16	3/8	.175	9/16	1/16	1/8	30
0282	1/4-28	3/4	1/4	1"	3/8	.175	5/8	1/16	1/8	30
0283	1/4-28	3/4	1/4	1-1/16	3/8	.175	11/16	1/16	1/8	30
0284	1/4-28	3/4	1/4	1-1/8	3/8	.175	3/4	1/16	1/8	30
0285	1/4-28	3/4	1/4	1-3/16	3/8	.175	13/16	1/16	1/8	30
0286	1/4-28	3/4	1/4	1-1/4	3/8	.175	7/8	1/16	1/8	30
0287	1/4-28	3/4	1/4	1-5/16	3/8	.175	15/16	1/16	1/8	30
0288	1/4-28	3/4	1/4	1-3/8	3/8	.175	1"	1/16	1/8	30
0289	1/4-28	3/4	1/4	1-7/16	3/8	.175	1-1/16	1/16	1/8	30
0290	1/4-28	3/4	1/4	1-1/2	3/8	.175	1-1/8	1/16	1/8	30
0291	1/4-28	3/4	1/4	1-9/16	3/8	.175	1-3/16	1/16	1/8	30
0292	1/4-28	3/4	1/4	1-5/8	3/8	.175	1-1/4	1/16	1/8	30
0293	1/4-28	3/4	1/4	1-11/16	3/8	.175	1-5/16	1/16	1/8	30
0294	1/4-28	3/4	1/4	1-3/4	3/8	.175	1-3/8	1/16	1/8	30
0295	1/4-28	3/4	1/4	1-13/16	3/8	.175	1-7/16	1/16	1/8	30
0296	1/4-28	3/4	1/4	1-7/8	3/8	.175	1-1/2	1/16	1/8	30
0297	1/4-28	3/4	1/4	1-15/16	3/8	.175	1-9/16	1/16	1/8	30
0298	1/4-28	3/4	1/4	2"	3/8	.175	1-5/8	1/16	1/8	30
0299	5/16-18	9/16	1/4	1"	3/8	.235	5/8	1/16	3/32	30
0300	5/16-18	9/16	1/4	1-1/16	3/8	.235	11/16	1/16	3/32	30
0301	5/16-18	9/16	1/4	1-1/8	3/8	.235	3/4	1/16	3/32	30
0302	5/16-18	9/16	1/4	1-3/16	3/8	.235	13/16	1/16	3/32	30
0303	5/16-18	9/16	1/4	1-1/4	3/8	.235	7/8	1/16	3/32	30
0304	5/16-18	9/16	1/4	1-5/16	3/8	.235	15/16	1/16	3/32	30
0305	5/16-18	9/16	1/4	1-3/8	3/8	.235	1"	1/16	3/32	30
0306	5/16-18	9/16	1/4	1-7/16	3/8	.235	1-1/16	1/16	3/32	30
0307	5/16-18	9/16	1/4	1-1/2	3/8	.235	1-1/8	1/16	3/32	30
0308	5/16-18	9/16	1/4	1-9/16	3/8	.235	1-3/16	1/16	3/32	30
0309	5/16-18	9/16	1/4	1-5/8	3/8	.235	1-1/4	1/16	3/32	30
0310	5/16-18	9/16	1/4	1-11/16	3/8	.235	1-5/16	1/16	3/32	30
0311	5/16-18	9/16	1/4	1-3/4	3/8	.235	1-3/8	1/16	3/32	30
0312	5/16-18	9/16	1/4	1-13/16	3/8	.235	1-7/16	1/16	3/32	30
0313	5/16-18	9/16	1/4	1-7/8	3/8	.235	1-1/2	1/16	3/32	30
0314	5/16-18	9/16	1/4	1-15/16	3/8	.235	1-9/16	1/16	3/32	30
0315	5/16-18	9/16	1/4	2"	3/8	.235	1-5/8	1/16	3/32	30
0316	5/16-18	3/4	1/4	1"	3/8	.235	5/8	1/16	1/8	30
0317	5/16-18	3/4	1/4	1-1/16	3/8	.235	11/16	1/16	1/8	30



# CAPTIVE PANEL SCREW – STYLE 1

See page 11 for ordering code  
 See page 9 for finish codes  
 For non-standard parts contact Sales Office

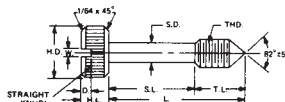

Available with thread locking products, see page vii

PART NO.	THD.	H.D. +.015 -.000	H.L. ±.010	L. ±.015	T.L. ±.015	S.D. ±.005	S.L. ±.010	W. +.005 -.000	D. +.010 -.000	KNURL TPI
0318	5/16-18	3/4	1/4	1-1/8	3/8	.235	3/4	1/16	1/8	30
0319	5/16-18	3/4	1/4	1-3/16	3/8	.235	13/16	1/16	1/8	30
0320	5/16-18	3/4	1/4	1-1/4	3/8	.235	7/8	1/16	1/8	30
0321	5/16-18	3/4	1/4	1-5/16	3/8	.235	15/16	1/16	1/8	30
0322	5/16-18	3/4	1/4	1-3/8	3/8	.235	1"	1/16	1/8	30
0323	5/16-18	3/4	1/4	1-7/16	3/8	.235	1-1/16	1/16	1/8	30
0324	5/16-18	3/4	1/4	1-1/2	3/8	.235	1-1/8	1/16	1/8	30
0325	5/16-18	3/4	1/4	1-9/16	3/8	.235	1-3/16	1/16	1/8	30
0326	5/16-18	3/4	1/4	1-5/8	3/8	.235	1-1/4	1/16	1/8	30
0327	5/16-18	3/4	1/4	1-11/16	3/8	.235	1-5/16	1/16	1/8	30
0328	5/16-18	3/4	1/4	1-3/4	3/8	.235	1-3/8	1/16	1/8	30
0329	5/16-18	3/4	1/4	1-13/16	3/8	.235	1-7/16	1/16	1/8	30
0330	5/16-18	3/4	1/4	1-7/8	3/8	.235	1-1/2	1/16	1/8	30
0331	5/16-18	3/4	1/4	1-15/16	3/8	.235	1-9/16	1/16	1/8	30
0332	5/16-18	3/4	1/4	2"	3/8	.235	1-5/8	1/16	1/8	30
0333	5/16-24	9/16	1/4	1"	3/8	.235	5/8	1/16	3/32	30
0334	5/16-24	9/16	1/4	1-1/16	3/8	.235	11/16	1/16	3/32	30
0335	5/16-24	9/16	1/4	1-1/8	3/8	.235	3/4	1/16	3/32	30
0336	5/16-24	9/16	1/4	1-3/16	3/8	.235	13/16	1/16	3/32	30
0337	5/16-24	9/16	1/4	1-1/4	3/8	.235	7/8	1/16	3/32	30
0338	5/16-24	9/16	1/4	1-5/16	3/8	.235	15/16	1/16	3/32	30
0339	5/16-24	9/16	1/4	1-3/8	3/8	.235	1"	1/16	3/32	30
0340	5/16-24	9/16	1/4	1-7/16	3/8	.235	1-1/16	1/16	3/32	30
0341	5/16-24	9/16	1/4	1-1/2	3/8	.235	1-1/8	1/16	3/32	30
0342	5/16-24	9/16	1/4	1-9/16	3/8	.235	1-3/16	1/16	3/32	30
0343	5/16-24	9/16	1/4	1-5/8	3/8	.235	1-1/4	1/16	3/32	30
0344	5/16-24	9/16	1/4	1-11/16	3/8	.235	1-5/16	1/16	3/32	30
0345	5/16-24	9/16	1/4	1-3/4	3/8	.235	1-3/8	1/16	3/32	30
0346	5/16-24	9/16	1/4	1-13/16	3/8	.235	1-7/16	1/16	3/32	30
0347	5/16-24	9/16	1/4	1-7/8	3/8	.235	1-1/2	1/16	3/32	30
0348	5/16-24	9/16	1/4	1-15/16	3/8	.235	1-9/16	1/16	3/32	30
0349	5/16-24	9/16	1/4	2"	3/8	.235	1-5/8	1/16	3/32	30
0350	5/16-24	3/4	1/4	1"	3/8	.235	5/8	1/16	1/8	30
0351	5/16-24	3/4	1/4	1-1/16	3/8	.235	11/16	1/16	1/8	30
0352	5/16-24	3/4	1/4	1-1/8	3/8	.235	3/4	1/16	1/8	30
0353	5/16-24	3/4	1/4	1-3/16	3/8	.235	13/16	1/16	1/8	30
0354	5/16-24	3/4	1/4	1-1/4	3/8	.235	7/8	1/16	1/8	30
0355	5/16-24	3/4	1/4	1-5/16	3/8	.235	15/16	1/16	1/8	30
0356	5/16-24	3/4	1/4	1-3/8	3/8	.235	1"	1/16	1/8	30
0357	5/16-24	3/4	1/4	1-7/16	3/8	.235	1-1/16	1/16	1/8	30
0358	5/16-24	3/4	1/4	1-1/2	3/8	.235	1-1/8	1/16	1/8	30
0359	5/16-24	3/4	1/4	1-9/16	3/8	.235	1-3/16	1/16	1/8	30
0360	5/16-24	3/4	1/4	1-5/8	3/8	.235	1-1/4	1/16	1/8	30
0361	5/16-24	3/4	1/4	1-11/16	3/8	.235	1-5/16	1/16	1/8	30
0362	5/16-24	3/4	1/4	1-3/4	3/8	.235	1-3/8	1/16	1/8	30
0363	5/16-24	3/4	1/4	1-13/16	3/8	.235	1-7/16	1/16	1/8	30
0364	5/16-24	3/4	1/4	1-7/8	3/8	.235	1-1/2	1/16	1/8	30
0365	5/16-24	3/4	1/4	1-15/16	3/8	.235	1-9/16	1/16	1/8	30
0366	5/16-24	3/4	1/4	2"	3/8	.235	1-5/8	1/16	1/8	30



# CAPTIVE PANEL SCREW – STYLE 2

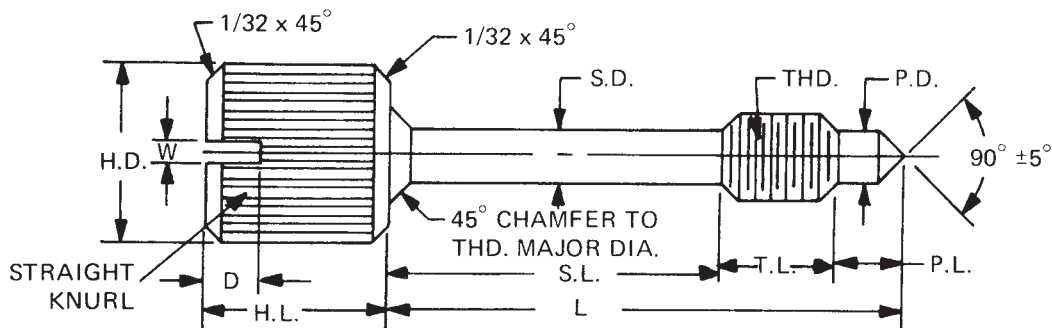

Available with thread locking products, see page vii

See page 11 for ordering code  
See page 9 for finish codes  
For non-standard parts contact Sales Office

PART NO.	THD.	H.D. +.015 -.000	H.L. ±.010	L. ±.015	T.L. +.000 -.015	S.D. ±.005	S.L. ±.010	P.D. +.000 -.010	P.L. ±.015	W. +.005 -.000	D. +.010 -.000	KNURL TPI
0367	4-40	1/4	1/4	3/8	1/8	.078	11/64	.078	5/64	3/64	5/64	35
0368	4-40	1/4	1/4	7/16	1/8	.078	15/64	.078	5/64	3/64	5/64	35
0369	4-40	1/4	1/4	1/2	1/8	.078	19/64	.078	5/64	3/64	5/64	35
0370	4-40	1/4	1/4	9/16	1/8	.078	23/64	.078	5/64	3/64	5/64	35
0371	4-40	1/4	1/4	5/8	1/8	.078	27/64	.078	5/64	3/64	5/64	35
0372	4-40	1/4	1/4	11/16	1/8	.078	31/64	.078	5/64	3/64	5/64	35
0373	4-40	1/4	1/4	3/4	1/8	.078	35/64	.078	5/64	3/64	5/64	35
0374	4-40	1/4	1/4	13/16	1/8	.078	39/64	.078	5/64	3/64	5/64	35
0375	4-40	1/4	1/4	7/8	1/8	.078	43/64	.078	5/64	3/64	5/64	35
0376	4-40	1/4	1/4	15/16	1/8	.078	47/64	.078	5/64	3/64	5/64	35
0377	4-40	1/4	1/4	1"	1/8	.078	51/64	.078	5/64	3/64	5/64	35
0378	4-40	5/16	5/16	3/8	1/8	.078	11/64	.078	5/64	3/64	5/64	35
0379	4-40	5/16	5/16	7/16	1/8	.078	15/64	.078	5/64	3/64	5/64	35
0380	4-40	5/16	5/16	1/2	1/8	.078	19/64	.078	5/64	3/64	5/64	35
0381	4-40	5/16	5/16	9/16	1/8	.078	23/64	.078	5/64	3/64	5/64	35
0382	4-40	5/16	5/16	5/8	1/8	.078	27/64	.078	5/64	3/64	5/64	35
0383	4-40	5/16	5/16	11/16	1/8	.078	31/64	.078	5/64	3/64	5/64	35
0384	4-40	5/16	5/16	3/4	1/8	.078	35/64	.078	5/64	3/64	5/64	35
0385	4-40	5/16	5/16	13/16	1/8	.078	39/64	.078	5/64	3/64	5/64	35
0386	4-40	5/16	5/16	7/8	1/8	.078	43/64	.078	5/64	3/64	5/64	35
0387	4-40	5/16	5/16	15/16	1/8	.078	47/64	.078	5/64	3/64	5/64	35
0388	4-40	5/16	5/16	1"	1/8	.078	51/64	.078	5/64	3/64	5/64	35
0389	6-32	5/16	5/16	7/16	7/32	.095	1/8	.095	3/32	3/64	5/64	35
0390	6-32	5/16	5/16	1/2	7/32	.095	3/16	.095	3/32	3/64	5/64	35
0391	6-32	5/16	5/16	9/16	7/32	.095	1/4	.095	3/32	3/64	5/64	35
0392	6-32	5/16	5/16	5/8	7/32	.095	5/16	.095	3/32	3/64	5/64	35
0393	6-32	5/16	5/16	11/16	7/32	.095	3/8	.095	3/32	3/64	5/64	35
0394	6-32	5/16	5/16	3/4	7/32	.095	7/16	.095	3/32	3/64	5/64	35
0395	6-32	5/16	5/16	13/16	7/32	.095	1/2	.095	3/32	3/64	5/64	35
0396	6-32	5/16	5/16	7/8	7/32	.095	9/16	.095	3/32	3/64	5/64	35
0397	6-32	5/16	5/16	15/16	7/32	.095	5/8	.095	3/32	3/64	5/64	35
0398	6-32	5/16	5/16	1"	7/32	.095	11/16	.095	3/32	3/64	5/64	35
0399	6-32	5/16	5/16	1-1/16	7/32	.095	3/4	.095	3/32	3/64	5/64	35
0400	6-32	5/16	5/16	1-1/8	7/32	.095	13/16	.095	3/32	3/64	5/64	35





# CAPTIVE PANEL SCREW – STYLE 2

See page 11 for ordering code  
 See page 9 for finish codes  
 For non-standard parts  
 contact Sales Office

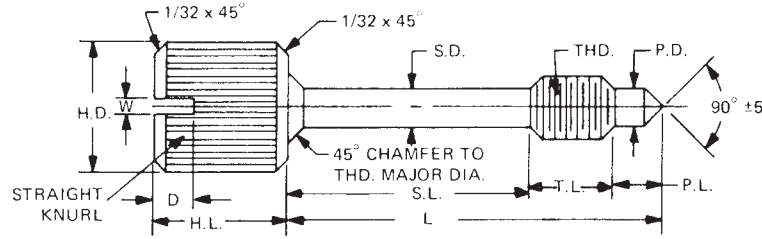

Available with thread locking products, see page vii

PART NO.	THD.	H.D. +.015 -.000	H.L. ±.010	L. ±.015	T.L. +.000 -.015	S.D. ±.005	S.L. ±.010	P.D. +.000 -.010	P.L. ±.015	W. +.005 -.000	D. +.010 -.000	KNURL TPI
0401	6-32	5/16	5/16	1-3/16	7/32	.095	7/8	.095	3/32	3/64	5/64	35
0402	6-32	5/16	5/16	1-1/4	7/32	.095	15/16	.095	3/32	3/64	5/64	35
0403	8-32	5/16	5/16	7/16	7/32	.120	1/8	.120	3/32	3/64	5/64	35
0404	8-32	5/16	5/16	1/2	7/32	.120	3/16	.120	3/32	3/64	5/64	35
0405	8-32	5/16	5/16	9/16	7/32	.120	1/4	.120	3/32	3/64	5/64	35
0406	8-32	5/16	5/16	5/8	7/32	.120	5/16	.120	3/32	3/64	5/64	35
0407	8-32	5/16	5/16	11/16	7/32	.120	3/8	.120	3/32	3/64	5/64	35
0408	8-32	5/16	5/16	3/4	7/32	.120	7/16	.120	3/32	3/64	5/64	35
0409	8-32	5/16	5/16	13/16	7/32	.120	1/2	.120	3/32	3/64	5/64	35
0410	8-32	5/16	5/16	7/8	7/32	.120	9/16	.120	3/32	3/64	5/64	35
0411	8-32	5/16	5/16	15/16	7/32	.120	5/8	.120	3/32	3/64	5/64	35
0412	8-32	5/16	5/16	1"	7/32	.120	11/16	.120	3/32	3/64	5/64	35
0413	8-32	5/16	5/16	1-1/16	7/32	.120	3/4	.120	3/32	3/64	5/64	35
0414	8-32	5/16	5/16	1-1/8	7/32	.120	13/16	.120	3/32	3/64	5/64	35
0415	8-32	5/16	5/16	1-3/16	7/32	.120	7/8	.120	3/32	3/64	5/64	35
0416	8-32	5/16	5/16	1-1/4	7/32	.120	15/16	.120	3/32	3/64	5/64	35
0417	10-24	3/8	7/16	1/2	1/4	.130	3/32	.130	5/32	1/16	3/32	35
0418	10-24	3/8	7/16	9/16	1/4	.130	5/32	.130	5/32	1/16	3/32	35
0419	10-24	3/8	7/16	5/8	1/4	.130	7/32	.130	5/32	1/16	3/32	35
0420	10-24	3/8	7/16	11/16	1/4	.130	9/32	.130	5/32	1/16	3/32	35
0421	10-24	3/8	7/16	3/4	1/4	.130	11/32	.130	5/32	1/16	3/32	35
0422	10-24	3/8	7/16	13/16	1/4	.130	13/32	.130	5/32	1/16	3/32	35
0423	10-24	3/8	7/16	7/8	1/4	.130	15/32	.130	5/32	1/16	3/32	35
0424	10-24	3/8	7/16	15/16	1/4	.130	17/32	.130	5/32	1/16	3/32	35
0425	10-24	3/8	7/16	1"	1/4	.130	19/32	.130	5/32	1/16	3/32	35
0426	10-24	3/8	7/16	1-1/16	1/4	.130	21/32	.130	5/32	1/16	3/32	35
0427	10-24	3/8	7/16	1-1/8	1/4	.130	23/32	.130	5/32	1/16	3/32	35
0428	10-24	3/8	7/16	1-3/16	1/4	.130	25/32	.130	5/32	1/16	3/32	35
0429	10-24	3/8	7/16	1-1/4	1/4	.130	27/32	.130	5/32	1/16	3/32	35
0430	10-24	3/8	7/16	1-5/16	1/4	.130	29/32	.130	5/32	1/16	3/32	35
0431	10-24	3/8	7/16	1-3/8	1/4	.130	31/32	.130	5/32	1/16	3/32	35
0432	10-24	3/8	7/16	1-7/16	1/4	.130	1-1/32	.130	5/32	1/16	3/32	35
0433	10-24	3/8	7/16	1-1/2	1/4	.130	1-3/32	.130	5/32	1/16	3/32	35
0434	10-24	3/8	7/16	1-9/16	1/4	.130	1-5/32	.130	5/32	1/16	3/32	35
0435	10-24	3/8	7/16	1-5/8	1/4	.130	1-7/32	.130	5/32	1/16	3/32	35
0436	10-24	3/8	7/16	1-11/16	1/4	.130	1-9/32	.130	5/32	1/16	3/32	35
0437	10-24	3/8	7/16	1-3/4	1/4	.130	1-11/32	.130	5/32	1/16	3/32	35
0438	10-24	3/8	7/16	1-13/16	1/4	.130	1-13/32	.130	5/32	1/16	3/32	35
0439	10-24	3/8	7/16	1-7/8	1/4	.130	1-15/32	.130	5/32	1/16	3/32	35
0440	10-24	3/8	7/16	1-15/16	1/4	.130	1-17/32	.130	5/32	1/16	3/32	35
0441	10-24	3/8	7/16	2"	1/4	.130	1-19/32	.130	5/32	1/16	3/32	35



# CAPTIVE PANEL SCREW – STYLE 2

See page 11 for ordering code  
See page 9 for finish codes  
For non-standard parts  
contact Sales Office

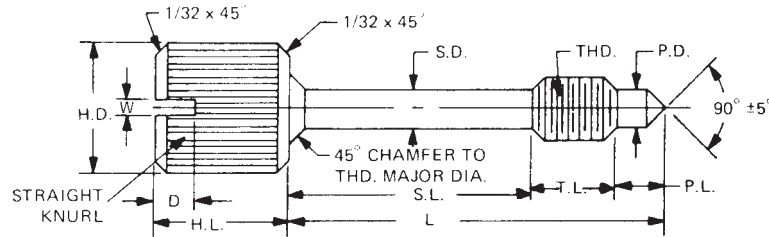

Available with thread locking products, see page vii

PART NO.	THD.	H.D. +.015 -.000	H.L. ±.010	L. ±.015	T.L. +.000 -.015	S.D. ±.005	S.L. ±.010	P.D. +.000 -.010	P.L. ±.015	W. +.005 -.000	D. +.010 -.000	KNURL TPI
0442	10-32	3/8	7/16	1/2	1/4	.130	3/32	.130	5/32	1/16	3/32	35
0443	10-32	3/8	7/16	9/16	1/4	.130	5/32	.130	5/32	1/16	3/32	35
0444	10-32	3/8	7/16	5/8	1/4	.130	7/32	.130	5/32	1/16	3/32	35
0445	10-32	3/8	7/16	11/16	1/4	.130	9/32	.130	5/32	1/16	3/32	35
0446	10-32	3/8	7/16	3/4	1/4	.130	11/32	.130	5/32	1/16	3/32	35
0447	10-32	3/8	7/16	13/16	1/4	.130	13/32	.130	5/32	1/16	3/32	35
0448	10-32	3/8	7/16	7/8	1/4	.130	15/32	.130	5/32	1/16	3/32	35
0449	10-32	3/8	7/16	15/16	1/4	.130	17/32	.130	5/32	1/16	3/32	35
0450	10-32	3/8	7/16	1"	1/4	.130	19/32	.130	5/32	1/16	3/32	35
0451	10-32	3/8	7/16	1-1/16	1/4	.130	21/32	.130	5/32	1/16	3/32	35
0452	10-32	3/8	7/16	1-1/8	1/4	.130	23/32	.130	5/32	1/16	3/32	35
0453	10-32	3/8	7/16	1-3/16	1/4	.130	25/32	.130	5/32	1/16	3/32	35
0454	10-32	3/8	7/16	1-1/4	1/4	.130	27/32	.130	5/32	1/16	3/32	35
0455	10-32	3/8	7/16	1-5/16	1/4	.130	29/32	.130	5/32	1/16	3/32	35
0456	10-32	3/8	7/16	1-3/8	1/4	.130	31/32	.130	5/32	1/16	3/32	35
0457	10-32	3/8	7/16	1-7/16	1/4	.130	1-1/32	.130	5/32	1/16	3/32	35
0458	10-32	3/8	7/16	1-1/2	1/4	.130	1-3/32	.130	5/32	1/16	3/32	35
0459	10-32	3/8	7/16	1-9/16	1/4	.130	1-5/32	.130	5/32	1/16	3/32	35
0460	10-32	3/8	7/16	1-5/8	1/4	.130	1-7/32	.130	5/32	1/16	3/32	35
0461	10-32	3/8	7/16	1-11/16	1/4	.130	1-9/32	.130	5/32	1/16	3/32	35
0462	10-32	3/8	7/16	1-3/4	1/4	.130	1-11/32	.130	5/32	1/16	3/32	35
0463	10-32	3/8	7/16	1-13/16	1/4	.130	1-13/32	.130	5/32	1/16	3/32	35
0464	10-32	3/8	7/16	1-7/8	1/4	.130	1-15/32	.130	5/32	1/16	3/32	35
0465	10-32	3/8	7/16	1-15/16	1/4	.130	1-17/32	.130	5/32	1/16	3/32	35
0466	10-32	3/8	7/16	2"	1/4	.130	1-19/32	.130	5/32	1/16	3/32	35
0467	1/4-20	1/2	9/16	5/8	5/16	.175	1/8	.175	3/16	5/64	3/32	30
0468	1/4-20	1/2	9/16	11/16	5/16	.175	3/16	.175	3/16	5/64	3/32	30
0469	1/4-20	1/2	9/16	3/4	5/16	.175	1/4	.175	3/16	5/64	3/32	30
0470	1/4-20	1/2	9/16	13/16	5/16	.175	5/16	.175	3/16	5/64	3/32	30
0471	1/4-20	1/2	9/16	7/8	5/16	.175	3/8	.175	3/16	5/64	3/32	30
0472	1/4-20	1/2	9/16	15/16	5/16	.175	7/16	.175	3/16	5/64	3/32	30
0473	1/4-20	1/2	9/16	1"	5/16	.175	1/2	.175	3/16	5/64	3/32	30
0474	1/4-20	1/2	9/16	1-1/16	5/16	.175	9/16	.175	3/16	5/64	3/32	30
0475	1/4-20	1/2	9/16	1-1/8	5/16	.175	5/8	.175	3/16	5/64	3/32	30
0476	1/4-20	1/2	9/16	1-3/16	5/16	.175	11/16	.175	3/16	5/64	3/32	30
0477	1/4-20	1/2	9/16	1-1/4	5/16	.175	3/4	.175	3/16	5/64	3/32	30
0478	1/4-20	1/2	9/16	1-5/16	5/16	.175	13/16	.175	3/16	5/64	3/32	30
0479	1/4-20	1/2	9/16	1-3/8	5/16	.175	7/8	.175	3/16	5/64	3/32	30
0480	1/4-20	1/2	9/16	1-7/16	5/16	.175	15/16	.175	3/16	5/64	3/32	30
0481	1/4-20	1/2	9/16	1-1/2	5/16	.175	1"	.175	3/16	5/64	3/32	30
0482	1/4-20	1/2	9/16	1-9/16	5/16	.175	1-1/16	.175	3/16	5/64	3/32	30



# CAPTIVE PANEL SCREW – STYLE 2

See page 11 for ordering code  
 See page 9 for finish codes  
 For non-standard parts  
 contact Sales Office

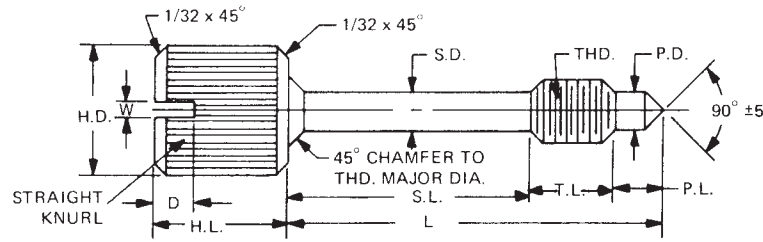

Available with thread locking products, see page vii

PART NO.	THD.	H.D. +.015 -.000	H.L. ±.010	L. ±.015	T.L. +.000 -.015	S.D. ±.005	S.L. ±.010	P.D. +.000 -.010	P.L. ±.015	W. +.005 -.000	D. +.010 -.000	KNURL TPI
0483	1/4-20	1/2	9/16	1-5/8	5/16	.175	1-1/8	.175	3/16	5/64	3/32	30
0484	1/4-20	1/2	9/16	1-11/16	5/16	.175	1-3/16	.175	3/16	5/64	3/32	30
0485	1/4-20	1/2	9/16	1-3/4	5/16	.175	1-1/4	.175	3/16	5/64	3/32	30
0486	1/4-20	1/2	9/16	1-13/16	5/16	.175	1-5/16	.175	3/16	5/64	3/32	30
0487	1/4-20	1/2	9/16	1-7/8	5/16	.175	1-3/8	.175	3/16	5/64	3/32	30
0488	1/4-20	1/2	9/16	1-15/16	5/16	.175	1-7/16	.175	3/16	5/64	3/32	30
0489	1/4-20	1/2	9/16	2"	5/16	.175	1-1/2	.175	3/16	5/64	3/32	30
0490	1/4-28	1/2	9/16	5/8	5/16	.175	1/8	.175	3/16	5/64	3/32	30
0491	1/4-28	1/2	9/16	11/16	5/16	.175	3/16	.175	3/16	5/64	3/32	30
0492	1/4-28	1/2	9/16	3/4	5/16	.175	1/4	.175	3/16	5/64	3/32	30
0493	1/4-28	1/2	9/16	13/16	5/16	.175	5/16	.175	3/16	5/64	3/32	30
0494	1/4-28	1/2	9/16	7/8	5/16	.175	3/8	.175	3/16	5/64	3/32	30
0495	1/4-28	1/2	9/16	15/16	5/16	.175	7/16	.175	3/16	5/64	3/32	30
0496	1/4-28	1/2	9/16	1"	5/16	.175	1/2	.175	3/16	5/64	3/32	30
0497	1/4-28	1/2	9/16	1-1/16	5/16	.175	9/16	.175	3/16	5/64	3/32	30
0498	1/4-28	1/2	9/16	1-1/8	5/16	.175	5/8	.175	3/16	5/64	3/32	30
0499	1/4-28	1/2	9/16	1-3/16	5/16	.175	11/16	.175	3/16	5/64	3/32	30
0500	1/4-28	1/2	9/16	1-1/4	5/16	.175	3/4	.175	3/16	5/64	3/32	30
0501	1/4-28	1/2	9/16	1-5/16	5/16	.175	13/16	.175	3/16	5/64	3/32	30
0502	1/4-28	1/2	9/16	1-3/8	5/16	.175	7/8	.175	3/16	5/64	3/32	30
0503	1/4-28	1/2	9/16	1-7/16	5/16	.175	15/16	.175	3/16	5/64	3/32	30
0504	1/4-28	1/2	9/16	1-1/2	5/16	.175	1"	.175	3/16	5/64	3/32	30
0505	1/4-28	1/2	9/16	1-9/16	5/16	.175	1-1/16	.175	3/16	5/64	3/32	30
0506	1/4-28	1/2	9/16	1-5/8	5/16	.175	1-1/8	.175	3/16	5/64	3/32	30
0507	1/4-28	1/2	9/16	1-11/16	5/16	.175	1-3/16	.175	3/16	5/64	3/32	30
0508	1/4-28	1/2	9/16	1-3/4	5/16	.175	1-1/4	.175	3/16	5/64	3/32	30
0509	1/4-28	1/2	9/16	1-13/16	5/16	.175	1-5/16	.175	3/16	5/64	3/32	30
0510	1/4-28	1/2	9/16	1-7/8	5/16	.175	1-3/8	.175	3/16	5/64	3/32	30
0511	1/4-28	1/2	9/16	1-15/16	5/16	.175	1-7/16	.175	3/16	5/64	3/32	30
0512	1/4-28	1/2	9/16	2"	5/16	.175	1-1/2	.175	3/16	5/64	3/32	30
0513	5/16-18	5/8	11/16	7/8	3/8	.230	1/4	.230	1/4	3/32	1/8	30
0514	5/16-18	5/8	11/16	15/16	3/8	.230	5/16	.230	1/4	3/32	1/8	30
0515	5/16-18	5/8	11/16	1"	3/8	.230	3/8	.230	1/4	3/32	1/8	30
0516	5/16-18	5/8	11/16	1-1/16	3/8	.230	7/16	.230	1/4	3/32	1/8	30
0517	5/16-18	5/8	11/16	1-1/8	3/8	.230	1/2	.230	1/4	3/32	1/8	30
0518	5/16-18	5/8	11/16	1-3/16	3/8	.230	9/16	.230	1/4	3/32	1/8	30
0519	5/16-18	5/8	11/16	1-1/4	3/8	.230	5/8	.230	1/4	3/32	1/8	30
0520	5/16-18	5/8	11/16	1-5/16	3/8	.230	11/16	.230	1/4	3/32	1/8	30
0521	5/16-18	5/8	11/16	1-3/8	3/8	.230	3/4	.230	1/4	3/32	1/8	30
0522	5/16-18	5/8	11/16	1-7/16	3/8	.230	13/16	.230	1/4	3/32	1/8	30
0523	5/16-18	5/8	11/16	1-1/2	3/8	.230	7/8	.230	1/4	3/32	1/8	30



# CAPTIVE PANEL SCREW – STYLE 2

See page 11 for ordering code  
 See page 9 for finish codes  
 For non-standard parts  
 contact Sales Office

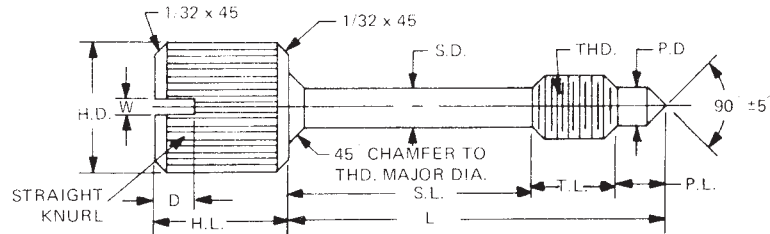

Available with thread locking products, see page vii

PART NO.	THD.	H.D. +.015 -.000	H.L. ±.010	L. ±.015	T.L. +.000 -.015	S.D. ±.005	S.L. ±.010	P.D. +.000 -.010	P.L. ±.015	W. +.005 -.000	D. +.010 -.000	KNURL TPI
0524	5/16-18	5/8	11/16	1-9/16	3/8	.230	15/16	.230	1/4	3/32	1/8	30
0525	5/16-18	5/8	11/16	1-5/8	3/8	.230	1"	.230	1/4	3/32	1/8	30
0526	5/16-18	5/8	11/16	1-11/16	3/8	.230	1-1/16	.230	1/4	3/32	1/8	30
0527	5/16-18	5/8	11/16	1-3/4	3/8	.230	1-1/8	.230	1/4	3/32	1/8	30
0528	5/16-18	5/8	11/16	1-13/16	3/8	.230	1-3/16	.230	1/4	3/32	1/8	30
0529	5/16-18	5/8	11/16	1-7/8	3/8	.230	1-1/4	.230	1/4	3/32	1/8	30
0530	5/16-18	5/8	11/16	1-15/16	3/8	.230	1-5/16	.230	1/4	3/32	1/8	30
0531	5/16-18	5/8	11/16	2"	3/8	.230	1-3/8	.230	1/4	3/32	1/8	30
0532	5/16-24	5/8	11/16	7/8	3/8	.230	1/4	.230	1/4	3/32	1/8	30
0533	5/16-24	5/8	11/16	15/16	3/8	.230	5/16	.230	1/4	3/32	1/8	30
0534	5/16-24	5/8	11/16	1"	3/8	.230	3/8	.230	1/4	3/32	1/8	30
0535	5/16-24	5/8	11/16	1-1/16	3/8	.230	7/16	.230	1/4	3/32	1/8	30
0536	5/16-24	5/8	11/16	1-1/8	3/8	.230	1/2	.230	1/4	3/32	1/8	30
0537	5/16-24	5/8	11/16	1-3/16	3/8	.230	9/16	.230	1/4	3/32	1/8	30
0538	5/16-24	5/8	11/16	1-1/4	3/8	.230	5/8	.230	1/4	3/32	1/8	30
0539	5/16-24	5/8	11/16	1-5/16	3/8	.230	11/16	.230	1/4	3/32	1/8	30
0540	5/16-24	5/8	11/16	1-3/8	3/8	.230	3/4	.230	1/4	3/32	1/8	30
0541	5/16-24	5/8	11/16	1-7/16	3/8	.230	13/16	.230	1/4	3/32	1/8	30
0542	5/16-24	5/8	11/16	1-1/2	3/8	.230	7/8	.230	1/4	3/32	1/8	30
0543	5/16-24	5/8	11/16	1-9/16	3/8	.230	15/16	.230	1/4	3/32	1/8	30
0544	5/16-24	5/8	11/16	1-5/8	3/8	.230	1"	.230	1/4	3/32	1/8	30
0545	5/16-24	5/8	11/16	1-11/16	3/8	.230	1-1/16	.230	1/4	3/32	1/8	30
0546	5/16-24	5/8	11/16	1-3/4	3/8	.230	1-1/8	.230	1/4	3/32	1/8	30
0547	5/16-24	5/8	11/16	1-13/16	3/8	.230	1-3/16	.230	1/4	3/32	1/8	30
0548	5/16-24	5/8	11/16	1-7/8	3/8	.230	1-1/4	.230	1/4	3/32	1/8	30
0549	5/16-24	5/8	11/16	1-15/16	3/8	.230	1-5/16	.230	1/4	3/32	1/8	30
0550	5/16-24	5/8	11/16	2"	3/8	.230	1-3/8	.230	1/4	3/32	1/8	30
0551	3/8-16	5/8	11/16	1"	3/8	.280	3/8	.280	1/4	3/32	1/8	30
0552	3/8-16	5/8	11/16	1-1/16	3/8	.280	7/16	.280	1/4	3/32	1/8	30
0553	3/8-16	5/8	11/16	1-1/8	3/8	.280	1/2	.280	1/4	3/32	1/8	30
0554	3/8-16	5/8	11/16	1-3/16	3/8	.280	9/16	.280	1/4	3/32	1/8	30
0555	3/8-16	5/8	11/16	1-1/4	3/8	.280	5/8	.280	1/4	3/32	1/8	30
0556	3/8-16	5/8	11/16	1-5/16	3/8	.280	11/16	.280	1/4	3/32	1/8	30
0557	3/8-16	5/8	11/16	1-3/8	3/8	.280	3/4	.280	1/4	3/32	1/8	30
0558	3/8-16	5/8	11/16	1-7/16	3/8	.280	13/16	.280	1/4	3/32	1/8	30
0559	3/8-16	5/8	11/16	1-1/2	3/8	.280	7/8	.280	1/4	3/32	1/8	30
0560	3/8-16	5/8	11/16	1-9/16	3/8	.280	15/16	.280	1/4	3/32	1/8	30
0561	3/8-16	5/8	11/16	1-5/8	3/8	.280	1"	.280	1/4	3/32	1/8	30
0562	3/8-16	5/8	11/16	1-11/16	3/8	.280	1-1/16	.280	1/4	3/32	1/8	30
0563	3/8-16	5/8	11/16	1-3/4	3/8	.280	1-1/8	.280	1/4	3/32	1/8	30
0564	3/8-16	5/8	11/16	1-13/16	3/8	.280	1-3/16	.280	1/4	3/32	1/8	30
0565	3/8-16	5/8	11/16	1-7/8	3/8	.280	1-1/4	.280	1/4	3/32	1/8	30
0566	3/8-16	5/8	11/16	1-15/16	3/8	.280	1-5/16	.280	1/4	3/32	1/8	30
0567	3/8-16	5/8	11/16	2"	3/8	.280	1-3/8	.280	1/4	3/32	1/8	30



# CAPTIVE PANEL SCREW – STYLE 3

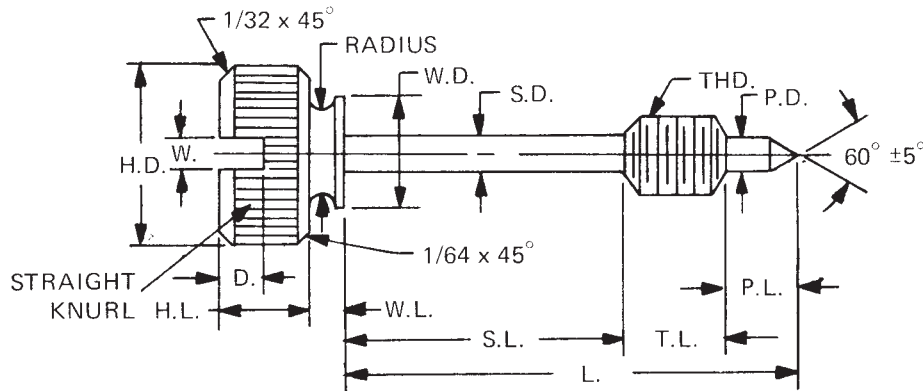

Available with thread locking products, see page vii

See page 11 for ordering code  
See page 9 for finish codes  
For non-standard parts contact Sales Office

PART NO.	THD.	H.D. +.015 -.000	H.L. ±.010	L. ±.015	T.L. ±.010	S.D. ±.005	S.L. ±.010	P.D. +.000 -.010	P.L. ±.015	W.D. ±.010	W.L. ±.010	W. +.005 -.000	D. +.010 -.000	KNURL TPI
0568	4-40	1/4	1/8	1/2	3/16	.078	3/16	.078	1/8	13/64	1/16	3/64	1/16	35
0569	4-40	1/4	1/8	9/16	3/16	.078	1/4	.078	1/8	13/64	1/16	3/64	1/16	35
0570	4-40	1/4	1/8	5/8	3/16	.078	5/16	.078	1/8	13/64	1/16	3/64	1/16	35
0571	4-40	1/4	1/8	11/16	3/16	.078	3/8	.078	1/8	13/64	1/16	3/64	1/16	35
0572	4-40	1/4	1/8	3/4	3/16	.078	7/16	.078	1/8	13/64	1/16	3/64	1/16	35
0573	4-40	1/4	1/8	13/16	3/16	.078	1/2	.078	1/8	13/64	1/16	3/64	1/16	35
0574	4-40	1/4	1/8	7/8	3/16	.078	9/16	.078	1/8	13/64	1/16	3/64	1/16	35
0575	4-40	1/4	1/8	15/16	3/16	.078	5/8	.078	1/8	13/64	1/16	3/64	1/16	35
0576	4-40	1/4	1/8	1"	3/16	.078	11/16	.078	1/8	13/64	1/16	3/64	1/16	35
0577	4-40	5/16	1/8	1/2	3/16	.078	3/16	.078	1/8	13/64	1/16	3/64	1/16	35
0578	4-40	5/16	1/8	9/16	3/16	.078	1/4	.078	1/8	13/64	1/16	3/64	1/16	35
0579	4-40	5/16	1/8	5/8	3/16	.078	5/16	.078	1/8	13/64	1/16	3/64	1/16	35
0580	4-40	5/16	1/8	11/16	3/16	.078	3/8	.078	1/8	13/64	1/16	3/64	1/16	35
0581	4-40	5/16	1/8	3/4	3/16	.078	7/16	.078	1/8	13/64	1/16	3/64	1/16	35
0582	4-40	5/16	1/8	13/16	3/16	.078	1/2	.078	1/8	13/64	1/16	3/64	1/16	35
0583	4-40	5/16	1/8	7/8	3/16	.078	9/16	.078	1/8	13/64	1/16	3/64	1/16	35
0584	4-40	5/16	1/8	15/16	3/16	.078	5/8	.078	1/8	13/64	1/16	3/64	1/16	35
0585	4-40	5/16	1/8	1"	3/16	.078	11/16	.078	1/8	13/64	1/16	3/64	1/16	35
0586	6-32	5/16	1/8	1/2	3/16	.095	3/16	.095	1/8	13/64	1/16	3/64	1/16	35
0587	6-32	5/16	1/8	9/16	3/16	.095	1/4	.095	1/8	13/64	1/16	3/64	1/16	35
0588	6-32	5/16	1/8	5/8	3/16	.095	5/16	.095	1/8	13/64	1/16	3/64	1/16	35
0589	6-32	5/16	1/8	11/16	3/16	.095	3/8	.095	1/8	13/64	1/16	3/64	1/16	35
0590	6-32	5/16	1/8	3/4	3/16	.095	7/16	.095	1/8	13/64	1/16	3/64	1/16	35
0591	6-32	5/16	1/8	13/16	3/16	.095	1/2	.095	1/8	13/64	1/16	3/64	1/16	35
0592	6-32	5/16	1/8	7/8	3/16	.095	9/16	.095	1/8	13/64	1/16	3/64	1/16	35
0593	6-32	5/16	1/8	15/16	3/16	.095	5/8	.095	1/8	13/64	1/16	3/64	1/16	35
0594	6-32	5/16	1/8	1"	3/16	.095	11/16	.095	1/8	13/64	1/16	3/64	1/16	35
0595	6-32	5/16	1/8	1-1/16	3/16	.095	3/4	.095	1/8	13/64	1/16	3/64	1/16	35
0596	6-32	5/16	1/8	1-1/8	3/16	.095	13/16	.095	1/8	13/64	1/16	3/64	1/16	35
0597	6-32	5/16	1/8	1-3/16	3/16	.095	7/8	.095	1/8	13/64	1/16	3/64	1/16	35
0598	6-32	5/16	1/8	1-1/4	3/16	.095	15/16	.095	1/8	13/64	1/16	3/64	1/16	35
0599	6-32	3/8	1/8	1/2	3/16	.095	3/16	.095	1/8	13/64	1/16	3/64	1/16	35
0600	6-32	3/8	1/8	9/16	3/16	.095	1/4	.095	1/8	13/64	1/16	3/64	1/16	35
0601	6-32	3/8	1/8	5/8	3/16	.095	5/16	.095	1/8	13/64	1/16	3/64	1/16	35
0602	6-32	3/8	1/8	11/16	3/16	.095	3/8	.095	1/8	13/64	1/16	3/64	1/16	35



# CAPTIVE PANEL SCREW – STYLE 3

See page 11 for ordering code  
 See page 9 for finish codes  
 For non-standard parts contact Sales Office

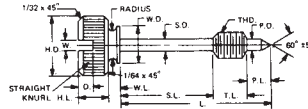

Available with thread locking products, see page vii

PART NO.	THD.	H.D. +.015 -.000	H.L. ±.010	L. ±.015	T.L. ±.010	S.D. ±.005	S.L. ±.010	P.D. +.000 -.010	P.L. ±.015	W.D. ±.010	W.L. ±.010	W. +.005 -.000	D. +.010 -.000	KNURL TPI
0603	6-32	3/8	1/8	3/4	3/16	.095	7/16	.095	1/8	13/64	1/16	3/64	1/16	35
0604	6-32	3/8	1/8	13/16	3/16	.095	1/2	.095	1/8	13/64	1/16	3/64	1/16	35
0605	6-32	3/8	1/8	7/8	3/16	.095	9/16	.095	1/8	13/64	1/16	3/64	1/16	35
0606	6-32	3/8	1/8	15/16	3/16	.095	5/8	.095	1/8	13/64	1/16	3/64	1/16	35
0607	6-32	3/8	1/8	1"	3/16	.095	11/16	.095	1/8	13/64	1/16	3/64	1/16	35
0608	6-32	3/8	1/8	1-1/16	3/16	.095	3/4	.095	1/8	13/64	1/16	3/64	1/16	35
0609	6-32	3/8	1/8	1-1/8	3/16	.095	13/16	.095	1/8	13/64	1/16	3/64	1/16	35
0610	6-32	3/8	1/8	1-3/16	3/16	.095	7/8	.095	1/8	13/64	1/16	3/64	1/16	35
0611	6-32	3/8	1/8	1-1/4	3/16	.095	15/16	.095	1/8	13/64	1/16	3/64	1/16	35
0612	8-32	1/2	3/16	1/2	1/4	.120	1/8	.120	1/8	13/32	1/16	1/16	3/32	30
0613	8-32	1/2	3/16	9/16	1/4	.120	3/16	.120	1/8	13/32	1/16	1/16	3/32	30
0614	8-32	1/2	3/16	5/8	1/4	.120	1/4	.120	1/8	13/32	1/16	1/16	3/32	30
0615	8-32	1/2	3/16	11/16	1/4	.120	5/16	.120	1/8	13/32	1/16	1/16	3/32	30
0616	8-32	1/2	3/16	3/4	1/4	.120	3/8	.120	1/8	13/32	1/16	1/16	3/32	30
0617	8-32	1/2	3/16	13/16	1/4	.120	7/16	.120	1/8	13/32	1/16	1/16	3/32	30
0618	8-32	1/2	3/16	7/8	1/4	.120	1/2	.120	1/8	13/32	1/16	1/16	3/32	30
0619	8-32	1/2	3/16	15/16	1/4	.120	9/16	.120	1/8	13/32	1/16	1/16	3/32	30
0620	8-32	1/2	3/16	1"	1/4	.120	5/8	.120	1/8	13/32	1/16	1/16	3/32	30
0621	8-32	1/2	3/16	1-1/16	1/4	.120	11/16	.120	1/8	13/32	1/16	1/16	3/32	30
0622	8-32	1/2	3/16	1-1/8	1/4	.120	3/4	.120	1/8	13/32	1/16	1/16	3/32	30
0623	8-32	1/2	3/16	1-3/16	1/4	.120	13/16	.120	1/8	13/32	1/16	1/16	3/32	30
0624	8-32	1/2	3/16	1-1/4	1/4	.120	7/8	.120	1/8	13/32	1/16	1/16	3/32	30
0625	8-32	1/2	3/16	1-5/16	1/4	.120	15/16	.120	1/8	13/32	1/16	1/16	3/32	30
0626	8-32	1/2	3/16	1-3/8	1/4	.120	1"	.120	1/8	13/32	1/16	1/16	3/32	30
0627	8-32	1/2	3/16	1-7/16	1/4	.120	1-1/16	.120	1/8	13/32	1/16	1/16	3/32	30
0628	8-32	1/2	3/16	1-1/2	1/4	.120	1-1/8	.120	1/8	13/32	1/16	1/16	3/32	30
0629	8-32	5/8	3/16	1/2	1/4	.120	1/8	.120	1/8	1/2	1/16	1/16	3/32	30
0630	8-32	5/8	3/16	9/16	1/4	.120	3/16	.120	1/8	1/2	1/16	1/16	3/32	30
0631	8-32	5/8	3/16	5/8	1/4	.120	1/4	.120	1/8	1/2	1/16	1/16	3/32	30
0632	8-32	5/8	3/16	11/16	1/4	.120	5/16	.120	1/8	1/2	1/16	1/16	3/32	30
0633	8-32	5/8	3/16	3/4	1/4	.120	3/8	.120	1/8	1/2	1/16	1/16	3/32	30
0634	8-32	5/8	3/16	13/16	1/4	.120	7/16	.120	1/8	1/2	1/16	1/16	3/32	30
0635	8-32	5/8	3/16	7/8	1/4	.120	1/2	.120	1/8	1/2	1/16	1/16	3/32	30
0636	8-32	5/8	3/16	15/16	1/4	.120	9/16	.120	1/8	1/2	1/16	1/16	3/32	30
0637	8-32	5/8	3/16	1"	1/4	.120	5/8	.120	1/8	1/2	1/16	1/16	3/32	30
0638	8-32	5/8	3/16	1-1/16	1/4	.120	11/16	.120	1/8	1/2	1/16	1/16	3/32	30
0639	8-32	5/8	3/16	1-1/8	1/4	.120	3/4	.120	1/8	1/2	1/16	1/16	3/32	30
0640	8-32	5/8	3/16	1-3/16	1/4	.120	13/16	.120	1/8	1/2	1/16	1/16	3/32	30
0641	8-32	5/8	3/16	1-1/4	1/4	.120	7/8	.120	1/8	1/2	1/16	1/16	3/32	30
0642	8-32	5/8	3/16	1-5/16	1/4	.120	15/16	.120	1/8	1/2	1/16	1/16	3/32	30
0643	8-32	5/8	3/16	1-3/8	1/4	.120	1"	.120	1/8	1/2	1/16	1/16	3/32	30
0644	8-32	5/8	3/16	1-7/16	1/4	.120	1-1/16	.120	1/8	1/2	1/16	1/16	3/32	30
0645	8-32	5/8	3/16	1-1/2	1/4	.120	1-1/8	.120	1/8	1/2	1/16	1/16	3/32	30
0646	10-24	1/2	3/16	1/2	1/4	.130	1/8	.130	1/8	13/32	1/16	1/16	3/32	30
0647	10-24	1/2	3/16	9/16	1/4	.130	3/16	.130	1/8	13/32	1/16	1/16	3/32	30
0648	10-24	1/2	3/16	5/8	1/4	.130	1/4	.130	1/8	13/32	1/16	1/16	3/32	30
0649	10-24	1/2	3/16	11/16	1/4	.130	5/16	.130	1/8	13/32	1/16	1/16	3/32	30
0650	10-24	1/2	3/16	3/4	1/4	.130	3/8	.130	1/8	13/32	1/16	1/16	3/32	30
0651	10-24	1/2	3/16	13/16	1/4	.130	7/16	.130	1/8	13/32	1/16	1/16	3/32	30



# CAPTIVE PANEL SCREW – STYLE 3

See page 11 for ordering code  
 See page 9 for finish codes  
 For non-standard parts contact Sales Office

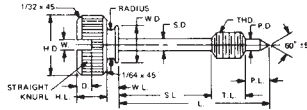

Available with thread locking products, see page vii

PART NO.	THD.	H.D. +.015 -.000	H.L. ±.010	L. ±.015	T.L. ±.010	S.D. ±.005	S.L. ±.010	P.D. +.000 -.010	P.L. ±.015	W.D. ±.010	W.L. ±.010	W. +.005 -.000	D. +.010 -.000	KNURL TPI
0652	10-24	1/2	3/16	7/8	1/4	.130	1/2	.130	1/8	13/32	1/16	1/16	3/32	30
0653	10-24	1/2	3/16	15/16	1/4	.130	9/16	.130	1/8	13/32	1/16	1/16	3/32	30
0654	10-24	1/2	3/16	1"	1/4	.130	5/8	.130	1/8	13/32	1/16	1/16	3/32	30
0655	10-24	1/2	3/16	1-1/16	1/4	.130	11/16	.130	1/8	13/32	1/16	1/16	3/32	30
0656	10-24	1/2	3/16	1-1/8	1/4	.130	3/4	.130	1/8	13/32	1/16	1/16	3/32	30
0657	10-24	1/2	3/16	1-3/16	1/4	.130	13/16	.130	1/8	13/32	1/16	1/16	3/32	30
0658	10-24	1/2	3/16	1-1/4	1/4	.130	7/8	.130	1/8	13/32	1/16	1/16	3/32	30
0659	10-24	1/2	3/16	1-5/16	1/4	.130	15/16	.130	1/8	13/32	1/16	1/16	3/32	30
0660	10-24	1/2	3/16	1-3/8	1/4	.130	1"	.130	1/8	13/32	1/16	1/16	3/32	30
0661	10-24	1/2	3/16	1-7/16	1/4	.130	1-1/16	.130	1/8	13/32	1/16	1/16	3/32	30
0662	10-24	1/2	3/16	1-1/2	1/4	.130	1-1/8	.130	1/8	13/32	1/16	1/16	3/32	30
0663	10-24	5/8	3/16	1/2	1/4	.130	1/8	.130	1/8	1/2	1/16	1/16	3/32	30
0664	10-24	5/8	3/16	9/16	1/4	.130	3/16	.130	1/8	1/2	1/16	1/16	3/32	30
0665	10-24	5/8	3/16	5/8	1/4	.130	1/4	.130	1/8	1/2	1/16	1/16	3/32	30
0666	10-24	5/8	3/16	11/16	1/4	.130	5/16	.130	1/8	1/2	1/16	1/16	3/32	30
0667	10-24	5/8	3/16	3/4	1/4	.130	3/8	.130	1/8	1/2	1/16	1/16	3/32	30
0668	10-24	5/8	3/16	13/16	1/4	.130	7/16	.130	1/8	1/2	1/16	1/16	3/32	30
0669	10-24	5/8	3/16	7/8	1/4	.130	1/2	.130	1/8	1/2	1/16	1/16	3/32	30
0670	10-24	5/8	3/16	15/16	1/4	.130	9/16	.130	1/8	1/2	1/16	1/16	3/32	30
0671	10-24	5/8	3/16	1"	1/4	.130	5/8	.130	1/8	1/2	1/16	1/16	3/32	30
0672	10-24	5/8	3/16	1-1/16	1/4	.130	11/16	.130	1/8	1/2	1/16	1/16	3/32	30
0673	10-24	5/8	3/16	1-1/8	1/4	.130	3/4	.130	1/8	1/2	1/16	1/16	3/32	30
0674	10-24	5/8	3/16	1-3/16	1/4	.130	13/16	.130	1/8	1/2	1/16	1/16	3/32	30
0675	10-24	5/8	3/16	1-1/4	1/4	.130	7/8	.130	1/8	1/2	1/16	1/16	3/32	30
0676	10-24	5/8	3/16	1-5/16	1/4	.130	15/16	.130	1/8	1/2	1/16	1/16	3/32	30
0677	10-24	5/8	3/16	1-3/8	1/4	.130	1"	.130	1/8	1/2	1/16	1/16	3/32	30
0678	10-24	5/8	3/16	1-7/16	1/4	.130	1-1/16	.130	1/8	1/2	1/16	1/16	3/32	30
0679	10-24	5/8	3/16	1-1/2	1/4	.130	1-1/8	.130	1/8	1/2	1/16	1/16	3/32	30
0680	10-32	1/2	3/16	1/2	1/4	.130	1/8	.130	1/8	13/32	1/16	1/16	3/32	30
0681	10-32	1/2	3/16	9/16	1/4	.130	3/16	.130	1/8	13/32	1/16	1/16	3/32	30
0682	10-32	1/2	3/16	5/8	1/4	.130	1/4	.130	1/8	13/32	1/16	1/16	3/32	30
0683	10-32	1/2	3/16	11/16	1/4	.130	5/16	.130	1/8	13/32	1/16	1/16	3/32	30
0684	10-32	1/2	3/16	3/4	1/4	.130	3/8	.130	1/8	13/32	1/16	1/16	3/32	30
0685	10-32	1/2	3/16	13/16	1/4	.130	7/16	.130	1/8	13/32	1/16	1/16	3/32	30
0686	10-32	1/2	3/16	7/8	1/4	.130	1/2	.130	1/8	13/32	1/16	1/16	3/32	30
0687	10-32	1/2	3/16	15/16	1/4	.130	9/16	.130	1/8	13/32	1/16	1/16	3/32	30
0688	10-32	1/2	3/16	1"	1/4	.130	5/8	.130	1/8	13/32	1/16	1/16	3/32	30
0689	10-32	1/2	3/16	1-1/16	1/4	.130	11/16	.130	1/8	13/32	1/16	1/16	3/32	30
0690	10-32	1/2	3/16	1-1/8	1/4	.130	3/4	.130	1/8	13/32	1/16	1/16	3/32	30
0691	10-32	1/2	3/16	1-3/16	1/4	.130	13/16	.130	1/8	13/32	1/16	1/16	3/32	30
0692	10-32	1/2	3/16	1-1/4	1/4	.130	7/8	.130	1/8	13/32	1/16	1/16	3/32	30
0693	10-32	1/2	3/16	1-5/16	1/4	.130	15/16	.130	1/8	13/32	1/16	1/16	3/32	30
0694	10-32	1/2	3/16	1-3/8	1/4	.130	1"	.130	1/8	13/32	1/16	1/16	3/32	30
0695	10-32	1/2	3/16	1-7/16	1/4	.130	1-1/16	.130	1/8	13/32	1/16	1/16	3/32	30
0696	10-32	1/2	3/16	1-1/2	1/4	.130	1-1/8	.130	1/8	13/32	1/16	1/16	3/32	30
0697	10-32	5/8	3/16	1/2	1/4	.130	1/8	.130	1/8	1/2	1/16	1/16	3/32	30
0698	10-32	5/8	3/16	9/16	1/4	.130	3/16	.130	1/8	1/2	1/16	1/16	3/32	30
0699	10-32	5/8	3/16	5/8	1/4	.130	1/4	.130	1/8	1/2	1/16	1/16	3/32	30
0700	10-32	5/8	3/16	11/16	1/4	.130	5/16	.130	1/8	1/2	1/16	1/16	3/32	30



# CAPTIVE PANEL SCREW – STYLE 3

See page 11 for ordering code  
 See page 9 for finish codes  
 For non-standard parts contact Sales Office

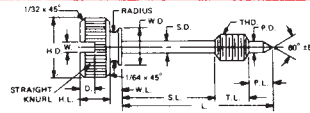

Available with thread locking products, see page vii

PART NO.	THD.	H.D. +.015 -.000	H.L. ±.010	L. ±.015	T.L. ±.010	S.D. ±.005	S.L. ±.010	P.D. +.000 -.010	P.L. ±.015	W.D. ±.010	W.L. ±.010	W. +.005 -.000	D. +.010 -.000	KNURL TPI
0701	10-32	5/8	3/16	3/4	1/4	.130	3/8	.130	1/8	1/2	1/16	1/16	3/32	30
0702	10-32	5/8	3/16	13/16	1/4	.130	7/16	.130	1/8	1/2	1/16	1/16	3/32	30
0703	10-32	5/8	3/16	7/8	1/4	.130	1/2	.130	1/8	1/2	1/16	1/16	3/32	30
0704	10-32	5/8	3/16	15/16	1/4	.130	9/16	.130	1/8	1/2	1/16	1/16	3/32	30
0705	10-32	5/8	3/16	1"	1/4	.130	5/8	.130	1/8	1/2	1/16	1/16	3/32	30
0706	10-32	5/8	3/16	1-1/16	1/4	.130	11/16	.130	1/8	1/2	1/16	1/16	3/32	30
0707	10-32	5/8	3/16	1-1/8	1/4	.130	3/4	.130	1/8	1/2	1/16	1/16	3/32	30
0708	10-32	5/8	3/16	1-3/16	1/4	.130	13/16	.130	1/8	1/2	1/16	1/16	3/32	30
0709	10-32	5/8	3/16	1-1/4	1/4	.130	7/8	.130	1/8	1/2	1/16	1/16	3/32	30
0710	10-32	5/8	3/16	1-5/16	1/4	.130	15/16	.130	1/8	1/2	1/16	1/16	3/32	30
0711	10-32	5/8	3/16	1-3/8	1/4	.130	1"	.130	1/8	1/2	1/16	1/16	3/32	30
0712	10-32	5/8	3/16	1-7/16	1/4	.130	1-1/16	.130	1/8	1/2	1/16	1/16	3/32	30
0713	10-32	5/8	3/16	1-1/2	1/4	.130	1-1/8	.130	1/8	1/2	1/16	1/16	3/32	30
0714	12-24	5/8	3/16	1/2	1/4	.150	1/8	.150	1/8	1/2	1/16	5/64	3/32	30
0715	12-24	5/8	3/16	9/16	1/4	.150	3/16	.150	1/8	1/2	1/16	5/64	3/32	30
0716	12-24	5/8	3/16	5/8	1/4	.150	1/4	.150	1/8	1/2	1/16	5/64	3/32	30
0717	12-24	5/8	3/16	11/16	1/4	.150	5/16	.150	1/8	1/2	1/16	5/64	3/32	30
0718	12-24	5/8	3/16	3/4	1/4	.150	3/8	.150	1/8	1/2	1/16	5/64	3/32	30
0719	12-24	5/8	3/16	13/16	1/4	.150	7/16	.150	1/8	1/2	1/16	5/64	3/32	30
0720	12-24	5/8	3/16	7/8	1/4	.150	1/2	.150	1/8	1/2	1/16	5/64	3/32	30
0721	12-24	5/8	3/16	15/16	1/4	.150	9/16	.150	1/8	1/2	1/16	5/64	3/32	30
0722	12-24	5/8	3/16	1"	1/4	.150	5/8	.150	1/8	1/2	1/16	5/64	3/32	30
0723	12-24	5/8	3/16	1-1/16	1/4	.150	11/16	.150	1/8	1/2	1/16	5/64	3/32	30
0724	12-24	5/8	3/16	1-1/8	1/4	.150	3/4	.150	1/8	1/2	1/16	5/64	3/32	30
0725	12-24	5/8	3/16	1-3/16	1/4	.150	13/16	.150	1/8	1/2	1/16	5/64	3/32	30
0726	12-24	5/8	3/16	1-1/4	1/4	.150	7/8	.150	1/8	1/2	1/16	5/64	3/32	30
0727	12-24	5/8	3/16	1-5/16	1/4	.150	15/16	.150	1/8	1/2	1/16	5/64	3/32	30
0728	12-24	5/8	3/16	1-3/8	1/4	.150	1"	.150	1/8	1/2	1/16	5/64	3/32	30
0729	12-24	5/8	3/16	1-7/16	1/4	.150	1-1/16	.150	1/8	1/2	1/16	5/64	3/32	30
0730	12-24	5/8	3/16	1-1/2	1/4	.150	1-1/8	.150	1/8	1/2	1/16	5/64	3/32	30
0731	1/4-20	5/8	3/16	3/4	3/8	.175	1/8	.175	1/4	1/2	1/16	5/64	3/32	30
0732	1/4-20	5/8	3/16	13/16	3/8	.175	3/16	.175	1/4	1/2	1/16	5/64	3/32	30
0733	1/4-20	5/8	3/16	7/8	3/8	.175	1/4	.175	1/4	1/2	1/16	5/64	3/32	30
0734	1/4-20	5/8	3/16	15/16	3/8	.175	5/16	.175	1/4	1/2	1/16	5/64	3/32	30
0735	1/4-20	5/8	3/16	1"	3/8	.175	3/8	.175	1/4	1/2	1/16	5/64	3/32	30
0736	1/4-20	5/8	3/16	1-1/16	3/8	.175	7/16	.175	1/4	1/2	1/16	5/64	3/32	30
0737	1/4-20	5/8	3/16	1-1/8	3/8	.175	1/2	.175	1/4	1/2	1/16	5/64	3/32	30
0738	1/4-20	5/8	3/16	1-3/16	3/8	.175	9/16	.175	1/4	1/2	1/16	5/64	3/32	30
0739	1/4-20	5/8	3/16	1-1/4	3/8	.175	5/8	.175	1/4	1/2	1/16	5/64	3/32	30
0740	1/4-20	5/8	3/16	1-5/16	3/8	.175	11/16	.175	1/4	1/2	1/16	5/64	3/32	30
0741	1/4-20	5/8	3/16	1-3/8	3/8	.175	3/4	.175	1/4	1/2	1/16	5/64	3/32	30
0742	1/4-20	5/8	3/16	1-7/16	3/8	.175	13/16	.175	1/4	1/2	1/16	5/64	3/32	30
0743	1/4-20	5/8	3/16	1-1/2	3/8	.175	7/8	.175	1/4	1/2	1/16	5/64	3/32	30
0744	1/4-20	5/8	3/16	1-9/16	3/8	.175	15/16	.175	1/4	1/2	1/16	5/64	3/32	30
0745	1/4-20	5/8	3/16	1-5/8	3/8	.175	1"	.175	1/4	1/2	1/16	5/64	3/32	30
0746	1/4-20	5/8	3/16	1-11/16	3/8	.175	1-1/16	.175	1/4	1/2	1/16	5/64	3/32	30
0747	1/4-20	5/8	3/16	1-3/4	3/8	.175	1-1/8	.175	1/4	1/2	1/16	5/64	3/32	30
0748	1/4-20	3/4	1/4	3/4	3/8	.175	1/8	.175	1/4	1/2	1/8	3/32	1/8	30
0749	1/4-20	3/4	1/4	13/16	3/8	.175	3/16	.175	1/4	1/2	1/8	3/32	1/8	30





# CAPTIVE PANEL SCREW – STYLE 3

See page 11 for ordering code  
 See page 9 for finish codes  
 For non-standard parts contact Sales Office

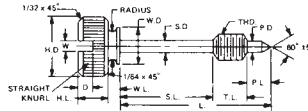

Available with thread locking products, see page vii

PART NO.	THD.	H.D. +.015 -.000	H.L. ±.010	L. ±.015	T.L. ±.010	S.D. ±.005	S.L. ±.010	P.D. +.000 -.010	P.L. ±.015	W.D. ±.010	W.L. ±.010	W. +.005 -.000	D. +.010 -.000	KNURL TPI
0750	1/4-20	3/4	1/4	7/8	3/8	.175	1/4	.175	1/4	1/2	1/8	3/32	1/8	30
0751	1/4-20	3/4	1/4	15/16	3/8	.175	5/16	.175	1/4	1/2	1/8	3/32	1/8	30
0752	1/4-20	3/4	1/4	1"	3/8	.175	3/8	.175	1/4	1/2	1/8	3/32	1/8	30
0753	1/4-20	3/4	1/4	1-1/16	3/8	.175	7/16	.175	1/4	1/2	1/8	3/32	1/8	30
0754	1/4-20	3/4	1/4	1-1/8	3/8	.175	1/2	.175	1/4	1/2	1/8	3/32	1/8	30
0755	1/4-20	3/4	1/4	1-3/16	3/8	.175	9/16	.175	1/4	1/2	1/8	3/32	1/8	30
0756	1/4-20	3/4	1/4	1-1/4	3/8	.175	5/8	.175	1/4	1/2	1/8	3/32	1/8	30
0757	1/4-20	3/4	1/4	1-5/16	3/8	.175	11/16	.175	1/4	1/2	1/8	3/32	1/8	30
0758	1/4-20	3/4	1/4	1-3/8	3/8	.175	3/4	.175	1/4	1/2	1/8	3/32	1/8	30
0759	1/4-20	3/4	1/4	1-7/16	3/8	.175	13/16	.175	1/4	1/2	1/8	3/32	1/8	30
0760	1/4-20	3/4	1/4	1-1/2	3/8	.175	7/8	.175	1/4	1/2	1/8	3/32	1/8	30
0761	1/4-20	3/4	1/4	1-9/16	3/8	.175	15/16	.175	1/4	1/2	1/8	3/32	1/8	30
0762	1/4-20	3/4	1/4	1-5/8	3/8	.175	1"	.175	1/4	1/2	1/8	3/32	1/8	30
0763	1/4-20	3/4	1/4	1-11/16	3/8	.175	1-1/16	.175	1/4	1/2	1/8	3/32	1/8	30
0764	1/4-20	3/4	1/4	1-3/4	3/8	.175	1-1/8	.175	1/4	1/2	1/8	3/32	1/8	30
0765	1/4-28	5/8	3/16	3/4	3/8	.175	1/8	.175	1/4	1/2	1/16	5/64	3/32	30
0766	1/4-28	5/8	3/16	13/16	3/8	.175	3/16	.175	1/4	1/2	1/16	5/64	3/32	30
0767	1/4-28	5/8	3/16	7/8	3/8	.175	1/4	.175	1/4	1/2	1/16	5/64	3/32	30
0768	1/4-28	5/8	3/16	15/16	3/8	.175	5/16	.175	1/4	1/2	1/16	5/64	3/32	30
0769	1/4-28	5/8	3/16	1"	3/8	.175	3/8	.175	1/4	1/2	1/16	5/64	3/32	30
0770	1/4-28	5/8	3/16	1-1/16	3/8	.175	7/16	.175	1/4	1/2	1/16	5/64	3/32	30
0771	1/4-28	5/8	3/16	1-1/8	3/8	.175	1/2	.175	1/4	1/2	1/16	5/64	3/32	30
0772	1/4-28	5/8	3/16	1-3/16	3/8	.175	9/16	.175	1/4	1/2	1/16	5/64	3/32	30
0773	1/4-28	5/8	3/16	1-1/4	3/8	.175	5/8	.175	1/4	1/2	1/16	5/64	3/32	30
0774	1/4-28	5/8	3/16	1-5/16	3/8	.175	11/16	.175	1/4	1/2	1/16	5/64	3/32	30
0775	1/4-28	5/8	3/16	1-3/8	3/8	.175	3/4	.175	1/4	1/2	1/16	5/64	3/32	30
0776	1/4-28	5/8	3/16	1-7/16	3/8	.175	13/16	.175	1/4	1/2	1/16	5/64	3/32	30
0777	1/4-28	5/8	3/16	1-1/2	3/8	.175	7/8	.175	1/4	1/2	1/16	5/64	3/32	30
0778	1/4-28	5/8	3/16	1-9/16	3/8	.175	15/16	.175	1/4	1/2	1/16	5/64	3/32	30
0779	1/4-28	5/8	3/16	1-5/8	3/8	.175	1"	.175	1/4	1/2	1/16	5/64	3/32	30
0780	1/4-28	5/8	3/16	1-11/16	3/8	.175	1-1/16	.175	1/4	1/2	1/16	5/64	3/32	30
0781	1/4-28	5/8	3/16	1-3/4	3/8	.175	1-1/8	.175	1/4	1/2	1/16	5/64	3/32	30
0782	1/4-28	3/4	1/4	3/4	3/8	.175	1/8	.175	1/4	1/2	1/8	3/32	1/8	30
0783	1/4-28	3/4	1/4	13/16	3/8	.175	3/16	.175	1/4	1/2	1/8	3/32	1/8	30
0784	1/4-28	3/4	1/4	7/8	3/8	.175	1/4	.175	1/4	1/2	1/8	3/32	1/8	30
0785	1/4-28	3/4	1/4	15/16	3/8	.175	5/16	.175	1/4	1/2	1/8	3/32	1/8	30
0786	1/4-28	3/4	1/4	1"	3/8	.175	3/8	.175	1/4	1/2	1/8	3/32	1/8	30
0787	1/4-28	3/4	1/4	1-1/16	3/8	.175	7/16	.175	1/4	1/2	1/8	3/32	1/8	30
0788	1/4-28	3/4	1/4	1-1/8	3/8	.175	1/2	.175	1/4	1/2	1/8	3/32	1/8	30
0789	1/4-28	3/4	1/4	1-3/16	3/8	.175	9/16	.175	1/4	1/2	1/8	3/32	1/8	30
0790	1/4-28	3/4	1/4	1-1/4	3/8	.175	5/8	.175	1/4	1/2	1/8	3/32	1/8	30
0791	1/4-28	3/4	1/4	1-5/16	3/8	.175	11/16	.175	1/4	1/2	1/8	3/32	1/8	30
0792	1/4-28	3/4	1/4	1-3/8	3/8	.175	3/4	.175	1/4	1/2	1/8	3/32	1/8	30
0793	1/4-28	3/4	1/4	1-7/16	3/8	.175	13/16	.175	1/4	1/2	1/8	3/32	1/8	30
0794	1/4-28	3/4	1/4	1-1/2	3/8	.175	7/8	.175	1/4	1/2	1/8	3/32	1/8	30
0795	1/4-28	3/4	1/4	1-9/16	3/8	.175	15/16	.175	1/4	1/2	1/8	3/32	1/8	30
0796	1/4-28	3/4	1/4	1-5/8	3/8	.175	1"	.175	1/4	1/2	1/8	3/32	1/8	30
0797	1/4-28	3/4	1/4	1-11/16	3/8	.175	1-1/16	.175	1/4	1/2	1/8	3/32	1/8	30
0798	1/4-28	3/4	1/4	1-3/4	3/8	.175	1-1/8	.175	1/4	1/2	1/8	3/32	1/8	30



# CAPTIVE PANEL SCREW – STYLE 4

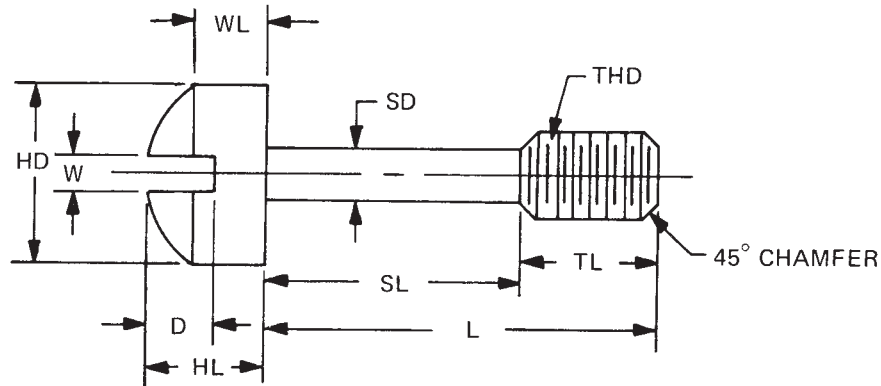

Available with thread locking products, see page vii

See page 11 for ordering code  
See page 9 for finish codes  
For non-standard parts contact Sales Office

PART NO.	THD.	H.D. ±.005	H.L. +.000 -.015	L. ±.015	T.L. ±.010	S.D. ±.005	S.L. ±.010	W.L. +.000 -.010	W. +.000 -.010	D. +.000 -.015
0799	2-56	1/8	.083	1/4	5/32	.061	3/32	.062	.031	.037
0800	2-56	1/8	.083	5/16	5/32	.061	5/32	.062	.031	.037
0801	2-56	1/8	.083	3/8	5/32	.061	7/32	.062	.031	.037
0802	2-56	1/8	.083	7/16	5/32	.061	9/32	.062	.031	.037
0803	2-56	1/8	.083	1/2	5/32	.061	11/32	.062	.031	.037
0804	2-56	1/8	.083	9/16	5/32	.061	13/32	.062	.031	.037
0805	2-56	1/8	.083	5/8	5/32	.061	15/32	.062	.031	.037
0806	2-56	1/8	.083	11/16	5/32	.061	17/32	.062	.031	.037
0807	2-56	1/8	.083	3/4	5/32	.061	19/32	.062	.031	.037
0808	3-48	5/32	.095	1/4	5/32	.070	3/32	.070	.035	.043
0809	3-48	5/32	.095	5/16	5/32	.070	5/32	.070	.035	.043
0810	3-48	5/32	.095	3/8	5/32	.070	7/32	.070	.035	.043
0811	3-48	5/32	.095	7/16	5/32	.070	9/32	.070	.035	.043
0812	3-48	5/32	.095	1/2	5/32	.070	11/32	.070	.035	.043
0813	3-48	5/32	.095	9/16	5/32	.070	13/32	.070	.035	.043
0814	3-48	5/32	.095	5/8	5/32	.070	15/32	.070	.035	.043
0815	3-48	5/32	.095	11/16	5/32	.070	17/32	.070	.035	.043
0816	3-48	5/32	.095	3/4	5/32	.070	19/32	.070	.035	.043
0817	4-40	11/64	.107	1/4	3/16	.078	1/16	.079	.039	.048
0818	4-40	11/64	.107	5/16	3/16	.078	1/8	.079	.039	.048
0819	4-40	11/64	.107	3/8	3/16	.078	3/16	.079	.039	.048
0820	4-40	11/64	.107	7/16	3/16	.078	1/4	.079	.039	.048
0821	4-40	11/64	.107	1/2	3/16	.078	5/16	.079	.039	.048
0822	4-40	11/64	.107	9/16	3/16	.078	3/8	.079	.039	.048
0823	4-40	11/64	.107	5/8	3/16	.078	7/16	.079	.039	.048
0824	4-40	11/64	.107	11/16	3/16	.078	1/2	.079	.039	.048
0825	4-40	11/64	.107	3/4	3/16	.078	9/16	.079	.039	.048
0826	4-40	11/64	.107	13/16	3/16	.078	5/8	.079	.039	.048
0827	4-40	11/64	.107	7/8	3/16	.078	11/16	.079	.039	.048
0828	4-40	11/64	.107	15/16	3/16	.078	3/4	.079	.039	.048
0829	4-40	11/64	.107	1"	3/16	.078	13/16	.079	.039	.048
0830	6-32	7/32	.132	5/16	7/32	.095	3/32	.096	.048	.060
0831	6-32	7/32	.132	3/8	7/32	.095	5/32	.096	.048	.060
0832	6-32	7/32	.132	7/16	7/32	.095	7/32	.096	.048	.060



# CAPTIVE PANEL SCREW – STYLE 4

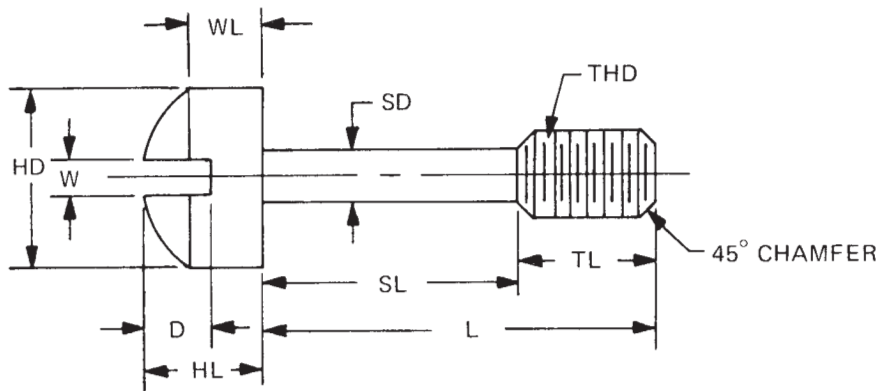

Available with thread locking products, see page vii

See page 11 for ordering code  
See page 9 for finish codes  
For non-standard parts contact Sales Office

PART NO.	THD.	H.D. ±.005	H.L. +.000 -.015	L. ±.015	T.L. ±.010	S.D. ±.005	S.L. ±.010	W.L. +.000 -.010	W. +.000 -.010	D. +.000 -.015
0833	6-32	7/32	.132	1/2	7/32	.095	9/32	.096	.048	.060
0834	6-32	7/32	.132	9/16	7/32	.095	11/32	.096	.048	.060
0835	6-32	7/32	.132	5/8	7/32	.095	13/32	.096	.048	.060
0836	6-32	7/32	.132	11/16	7/32	.095	15/32	.096	.048	.060
0837	6-32	7/32	.132	3/4	7/32	.095	17/32	.096	.048	.060
0838	6-32	7/32	.132	13/16	7/32	.095	19/32	.096	.048	.060
0839	6-32	7/32	.132	7/8	7/32	.095	21/32	.096	.048	.060
0840	6-32	7/32	.132	15/16	7/32	.095	23/32	.096	.048	.060
0841	6-32	7/32	.132	1"	7/32	.095	25/32	.096	.048	.060
0842	8-32	1/4	.156	5/16	7/32	.120	3/32	.113	.054	.071
0843	8-32	1/4	.156	3/8	7/32	.120	5/32	.113	.054	.071
0844	8-32	1/4	.156	7/16	7/32	.120	7/32	.113	.054	.071
0845	8-32	1/4	.156	1/2	7/32	.120	9/32	.113	.054	.071
0846	8-32	1/4	.156	9/16	7/32	.120	11/32	.113	.054	.071
0847	8-32	1/4	.156	5/8	7/32	.120	13/32	.113	.054	.071
0848	8-32	1/4	.156	11/16	7/32	.120	15/32	.113	.054	.071
0849	8-32	1/4	.156	3/4	7/32	.120	17/32	.113	.054	.071
0850	8-32	1/4	.156	13/16	7/32	.120	19/32	.113	.054	.071
0851	8-32	1/4	.156	7/8	7/32	.120	21/32	.113	.054	.071
0852	8-32	1/4	.156	15/16	7/32	.120	23/32	.113	.054	.071
0853	8-32	1/4	.156	1"	7/32	.120	25/32	.113	.054	.071
0854	8-32	1/4	.156	1-1/16	7/32	.120	27/32	.113	.054	.071
0855	8-32	1/4	.156	1-1/8	7/32	.120	29/32	.113	.054	.071
0856	8-32	1/4	.156	1-3/16	7/32	.120	31/32	.113	.054	.071
0857	8-32	1/4	.156	1-1/4	7/32	.120	1-1/32	.113	.054	.071
0858	10-24	5/16	.180	3/8	9/32	.130	3/32	.130	.060	.083
0859	10-24	5/16	.180	7/16	9/32	.130	5/32	.130	.060	.083
0860	10-24	5/16	.180	1/2	9/32	.130	7/32	.130	.060	.083
0861	10-24	5/16	.180	9/16	9/32	.130	9/32	.130	.060	.083
0862	10-24	5/16	.180	5/8	9/32	.130	11/32	.130	.060	.083
0863	10-24	5/16	.180	11/16	9/32	.130	13/32	.130	.060	.083
0864	10-24	5/16	.180	3/4	9/32	.130	15/32	.130	.060	.083



# CAPTIVE PANEL SCREW – STYLE 4

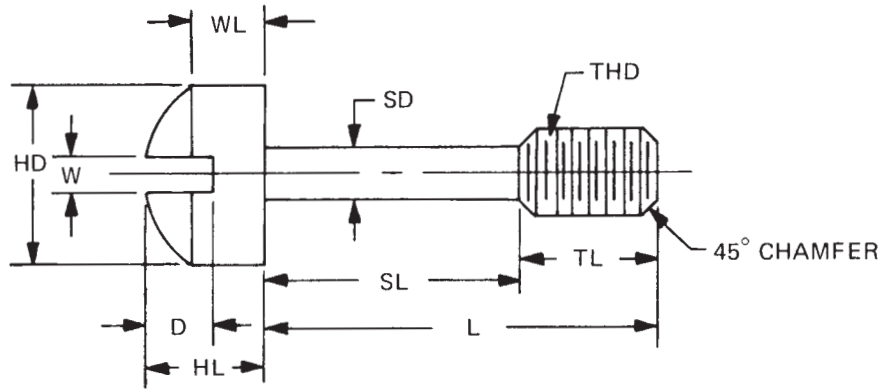

Available with thread locking products, see page vii

See page 11 for ordering code  
See page 9 for finish codes  
For non-standard parts contact Sales Office

PART NO.	THD.	H.D. ±.005	H.L. +.000 -.015	L. ±.015	T.L. ±.010	S.D. ±.005	S.L. ±.010	W.L. +.000 -.010	W. +.000 -.010	D. +.000 -.015
0865	10-24	5/16	.180	13/16	9/32	.130	17/32	.130	.060	.083
0866	10-24	5/16	.180	7/8	9/32	.130	19/32	.130	.060	.083
0867	10-24	5/16	.180	15/16	9/32	.130	21/32	.130	.060	.083
0868	10-24	5/16	.180	1"	9/32	.130	23/32	.130	.060	.083
0869	10-24	5/16	.180	1-1/16	9/32	.130	25/32	.130	.060	.083
0870	10-24	5/16	.180	1-1/8	9/32	.130	27/32	.130	.060	.083
0871	10-24	5/16	.180	1-3/16	9/32	.130	29/32	.130	.060	.083
0872	10-24	5/16	.180	1-1/4	9/32	.130	31/32	.130	.060	.083
0873	10-24	5/16	.180	1-5/16	9/32	.130	1-1/32	.130	.060	.083
0874	10-24	5/16	.180	1-3/8	9/32	.130	1-3/32	.130	.060	.083
0875	10-24	5/16	.180	1-7/16	9/32	.130	1-5/32	.130	.060	.083
0876	10-24	5/16	.180	1-1/2	9/32	.130	1-7/32	.130	.060	.083
0877	10-32	5/16	.180	3/8	9/32	.130	3/32	.130	.060	.083
0878	10-32	5/16	.180	7/16	9/32	.130	5/32	.130	.060	.083
0879	10-32	5/16	.180	1/2	9/32	.130	7/32	.130	.060	.083
0880	10-32	5/16	.180	9/16	9/32	.130	9/32	.130	.060	.083
0881	10-32	5/16	.180	5/8	9/32	.130	11/32	.130	.060	.083
0882	10-32	5/16	.180	11/16	9/32	.130	13/32	.130	.060	.083
0883	10-32	5/16	.180	3/4	9/32	.130	15/32	.130	.060	.083
0884	10-32	5/16	.180	13/16	9/32	.130	17/32	.130	.060	.083
0885	10-32	5/16	.180	7/8	9/32	.130	19/32	.130	.060	.083
0886	10-32	5/16	.180	15/16	9/32	.130	21/32	.130	.060	.083
0887	10-32	5/16	.180	1"	9/32	.130	23/32	.130	.060	.083
0888	10-32	5/16	.180	1-1/16	9/32	.130	25/32	.130	.060	.083
0889	10-32	5/16	.180	1-1/8	9/32	.130	27/32	.130	.060	.083
0890	10-32	5/16	.180	1-3/16	9/32	.130	29/32	.130	.060	.083
0891	10-32	5/16	.180	1-1/4	9/32	.130	31/32	.130	.060	.083
0892	10-32	5/16	.180	1-5/16	9/32	.130	1-1/32	.130	.060	.083
0893	10-32	5/16	.180	1-3/8	9/32	.130	1-3/32	.130	.060	.083
0894	10-32	5/16	.180	1-7/16	9/32	.130	1-5/32	.130	.060	.083
0895	10-32	5/16	.180	1-1/2	9/32	.130	1-7/32	.130	.060	.083

# CAPTIVE PANEL SCREW – STYLE 5

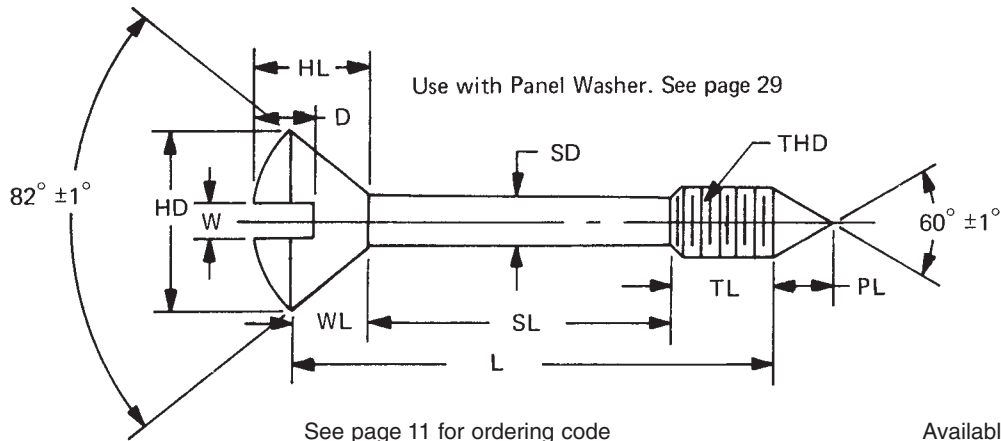

See page 11 for ordering code  
 See page 9 for finish codes  
 For non-standard parts contact Sales Office

Available with thread locking products, see page vii

PART NO.	THD.	H.D. ±.015	H.L. ±.010	L. ±.015	T.L. ±.015	P.L. ±.015	S.D. ±.005	S.L. REF.	W.L. +.020 -.000	W. +.005 -.000	D. +.000 -.010
0896	4-40	.210	.093	5/16	3/16	.096	.078	1/16	.067	1/32	1/16
0897	4-40	.210	.093	3/8	3/16	.096	.078	1/8	.067	1/32	1/16
0898	4-40	.210	.093	7/16	3/16	.096	.078	3/16	.067	1/32	1/16
0899	4-40	.210	.093	1/2	3/16	.096	.078	1/4	.067	1/32	1/16
0900	4-40	.210	.093	9/16	3/16	.096	.078	5/16	.067	1/32	1/16
0901	4-40	.210	.093	5/8	3/16	.096	.078	3/8	.067	1/32	1/16
0902	4-40	.210	.093	11/16	3/16	.096	.078	7/16	.067	1/32	1/16
0903	4-40	.210	.093	3/4	3/16	.096	.078	1/2	.067	1/32	1/16
0904	4-40	.210	.093	13/16	3/16	.096	.078	9/16	.067	1/32	1/16
0905	4-40	.210	.093	7/8	3/16	.096	.078	5/8	.067	1/32	1/16
0906	4-40	.210	.093	15/16	3/16	.096	.078	11/16	.067	1/32	1/16
0907	4-40	.210	.093	1"	3/16	.096	.078	3/4	.067	1/32	1/16
0908	6-32	.261	.117	7/16	1/4	.121	.095	3/32	.083	3/64	5/64
0909	6-32	.261	.117	1/2	1/4	.121	.095	5/32	.083	3/64	5/64
0910	6-32	.261	.117	9/16	1/4	.121	.095	7/32	.083	3/64	5/64
0911	6-32	.261	.117	5/8	1/4	.121	.095	9/32	.083	3/64	5/64
0912	6-32	.261	.117	11/16	1/4	.121	.095	11/32	.083	3/64	5/64
0913	6-32	.261	.117	3/4	1/4	.121	.095	13/32	.083	3/64	5/64
0914	6-32	.261	.117	13/16	1/4	.121	.095	15/32	.083	3/64	5/64
0915	6-32	.261	.117	7/8	1/4	.121	.095	17/32	.083	3/64	5/64
0916	6-32	.261	.117	15/16	1/4	.121	.095	19/32	.083	3/64	5/64
0917	6-32	.261	.117	1"	1/4	.121	.095	21/32	.083	3/64	5/64
0918	6-32	.261	.117	1-1/16	1/4	.121	.095	23/32	.083	3/64	5/64
0919	6-32	.261	.117	1-1/8	1/4	.121	.095	25/32	.083	3/64	5/64
0920	6-32	.261	.117	1-3/16	1/4	.121	.095	27/32	.083	3/64	5/64
0921	6-32	.261	.117	1-1/4	1/4	.121	.095	29/32	.083	3/64	5/64
0922	6-32	.261	.117	1-5/16	1/4	.121	.095	31/32	.083	3/64	5/64
0923	6-32	.261	.117	1-3/8	1/4	.121	.095	1-1/32	.083	3/64	5/64
0924	6-32	.261	.117	1-7/16	1/4	.121	.095	1-3/32	.083	3/64	5/64
0925	6-32	.261	.117	1-1/2	1/4	.121	.095	1-5/32	.083	3/64	5/64
0926	8-32	.312	.139	1/2	1/4	.142	.120	9/64	.100	3/64	5/64
0927	8-32	.312	.139	9/16	1/4	.142	.120	13/64	.100	3/64	5/64
0928	8-32	.312	.139	5/8	1/4	.142	.120	17/64	.100	3/64	5/64
0929	8-32	.312	.139	11/16	1/4	.142	.120	21/64	.100	3/64	5/64
0930	8-32	.312	.139	3/4	1/4	.142	.120	25/64	.100	3/64	5/64



# CAPTIVE PANEL SCREW — STYLE 5

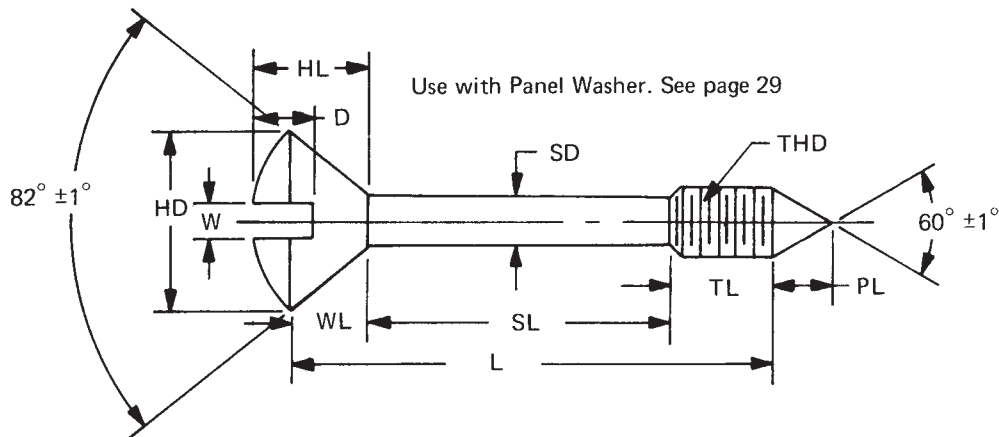

See page 11 for ordering code  
 See page 9 for finish codes  
 For non-standard parts contact Sales Office

Available with thread locking products, see page vii

PART NO.	THD.	H.D. ±.015	H.L. ±.010	L. ±.015	T.L. ±.015	P.L. ±.015	S.D. ±.005	S.L. REF.	W.L. +.020 -.000	W. +.005 -.000	D. +.000 -.010
0931	8-32	.312	.139	13/16	1/4	.142	.120	29/64	.100	3/64	5/64
0932	8-32	.312	.139	7/8	1/4	.142	.120	33/64	.100	3/64	5/64
0933	8-32	.312	.139	15/16	1/4	.142	.120	37/64	.100	3/64	5/64
0934	8-32	.312	.139	1"	1/4	.142	.120	41/64	.100	3/64	5/64
0935	8-32	.312	.139	1-1/16	1/4	.142	.120	45/64	.100	3/64	5/64
0936	8-32	.312	.139	1-1/8	1/4	.142	.120	49/64	.100	3/64	5/64
0937	8-32	.312	.139	1-3/16	1/4	.142	.120	53/64	.100	3/64	5/64
0938	8-32	.312	.139	1-1/4	1/4	.142	.120	57/64	.100	3/64	5/64
0939	8-32	.312	.139	1-5/16	1/4	.142	.120	61/64	.100	3/64	5/64
0940	8-32	.312	.139	1-3/8	1/4	.142	.120	1-1/64	.100	3/64	5/64
0941	8-32	.312	.139	1-7/16	1/4	.142	.120	1-5/64	.100	3/64	5/64
0942	8-32	.312	.139	1-1/2	1/4	.142	.120	1-9/64	.100	3/64	5/64
0943	10-24	.363	.162	1/2	1/4	.164	.130	1/8	.116	1/16	3/32
0944	10-24	.363	.162	9/16	1/4	.164	.130	3/16	.116	1/16	3/32
0945	10-24	.363	.162	5/8	1/4	.164	.130	1/4	.116	1/16	3/32
0946	10-24	.363	.162	11/16	1/4	.164	.130	5/16	.116	1/16	3/32
0947	10-24	.363	.162	3/4	1/4	.164	.130	3/8	.116	1/16	3/32
0948	10-24	.363	.162	13/16	1/4	.164	.130	7/16	.116	1/16	3/32
0949	10-24	.363	.162	7/8	1/4	.164	.130	1/2	.116	1/16	3/32
0950	10-24	.363	.162	15/16	1/4	.164	.130	9/16	.116	1/16	3/32
0951	10-24	.363	.162	1"	1/4	.164	.130	5/8	.116	1/16	3/32
0952	10-24	.363	.162	1-1/16	1/4	.164	.130	11/16	.116	1/16	3/32
0953	10-24	.363	.162	1-1/8	1/4	.164	.130	3/4	.116	1/16	3/32
0954	10-24	.363	.162	1-3/16	1/4	.164	.130	13/16	.116	1/16	3/32
0955	10-24	.363	.162	1-1/4	1/4	.164	.130	7/8	.116	1/16	3/32
0956	10-24	.363	.162	1-5/16	1/4	.164	.130	15/16	.116	1/16	3/32
0957	10-24	.363	.162	1-3/8	1/4	.164	.130	1"	.116	1/16	3/32
0958	10-24	.363	.162	1-7/16	1/4	.164	.130	1-1/16	.116	1/16	3/32
0959	10-24	.363	.162	1-1/2	1/4	.164	.130	1-1/8	.116	1/16	3/32
0960	10-24	.363	.162	1-9/16	1/4	.164	.130	1-3/16	.116	1/16	3/32
0961	10-24	.363	.162	1-5/8	1/4	.164	.130	1-1/4	.116	1/16	3/32



# CAPTIVE PANEL SCREW — STYLE 5

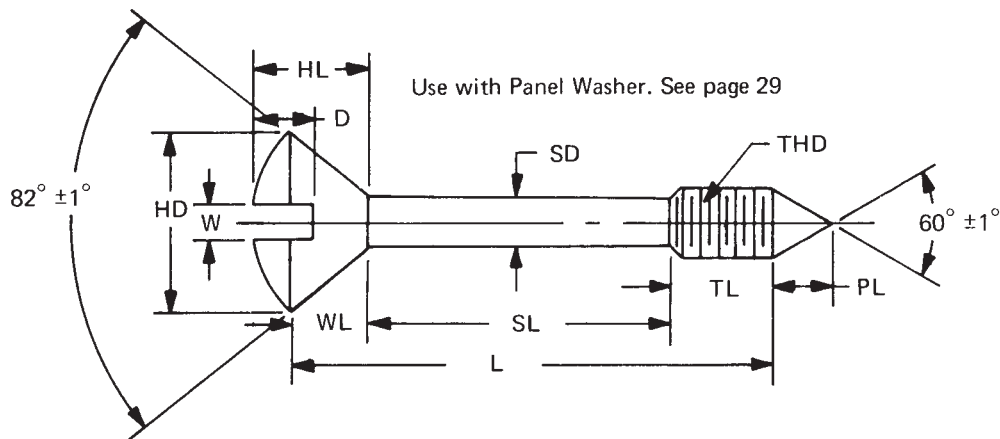

See page 11 for ordering code  
 See page 9 for finish codes  
 For non-standard parts contact Sales Office

Available with thread locking products, see page vii

PART NO.	THD.	H.D. ±.015	H.L. ±.010	L. ±.015	T.L. ±.015	P.L. ±.015	S.D. ±.005	S.L. REF.	W.L. +.020 -.000	W. +.005 -.000	D. +.000 -.010
0962	10-24	.363	.162	1-11/16	1/4	.164	.130	1-5/16	.116	1/16	3/32
0963	10-24	.363	.162	1-3/4	1/4	.164	.130	1-3/8	.116	1/16	3/32
0964	10-24	.363	.162	1-13/16	1/4	.164	.130	1-7/16	.116	1/16	3/32
0965	10-24	.363	.162	1-7/8	1/4	.164	.130	1-1/2	.116	1/16	3/32
0966	10-24	.363	.162	1-15/16	1/4	.164	.130	1-9/16	.116	1/16	3/32
0967	10-24	.363	.162	2"	1/4	.164	.130	1-5/8	.116	1/16	3/32
0968	10-32	.363	.162	1/2	1/4	.164	.130	1/8	.116	1/16	3/32
0969	10-32	.363	.162	9/16	1/4	.164	.130	3/16	.116	1/16	3/32
0970	10-32	.363	.162	5/8	1/4	.164	.130	1/4	.116	1/16	3/32
0971	10-32	.363	.162	11/16	1/4	.164	.130	5/16	.116	1/16	3/32
0972	10-32	.363	.162	3/4	1/4	.164	.130	3/8	.116	1/16	3/32
0973	10-32	.363	.162	13/16	1/4	.164	.130	7/16	.116	1/16	3/32
0974	10-32	.363	.162	7/8	1/4	.164	.130	1/2	.116	1/16	3/32
0975	10-32	.363	.162	15/16	1/4	.164	.130	9/16	.116	1/16	3/32
0976	10-32	.363	.162	1"	1/4	.164	.130	5/8	.116	1/16	3/32
0977	10-32	.363	.162	1-1/16	1/4	.164	.130	11/16	.116	1/16	3/32
0978	10-32	.363	.162	1-1/8	1/4	.164	.130	3/4	.116	1/16	3/32
0979	10-32	.363	.162	1-3/16	1/4	.164	.130	13/16	.116	1/16	3/32
0980	10-32	.363	.162	1-1/4	1/4	.164	.130	7/8	.116	1/16	3/32
0981	10-32	.363	.162	1-5/16	1/4	.164	.130	15/16	.116	1/16	3/32
0982	10-32	.363	.162	1-3/8	1/4	.164	.130	1"	.116	1/16	3/32
0983	10-32	.363	.162	1-7/16	1/4	.164	.130	1-1/16	.116	1/16	3/32
0984	10-32	.363	.162	1-1/2	1/4	.164	.130	1-1/8	.116	1/16	3/32
0985	10-32	.363	.162	1-9/16	1/4	.164	.130	1-3/16	.116	1/16	3/32
0986	10-32	.363	.162	1-5/8	1/4	.164	.130	1-1/4	.116	1/16	3/32
0987	10-32	.363	.162	1-11/16	1/4	.164	.130	1-5/16	.116	1/16	3/32
0988	10-32	.363	.162	1-3/4	1/4	.164	.130	1-3/8	.116	1/16	3/32
0989	10-32	.363	.162	1-13/16	1/4	.164	.130	1-7/16	.116	1/16	3/32
0990	10-32	.363	.162	1-7/8	1/4	.164	.130	1-1/2	.116	1/16	3/32
0991	10-32	.363	.162	1-15/16	1/4	.164	.130	1-9/16	.116	1/16	3/32
0992	10-32	.363	.162	2"	1/4	.164	.130	1-5/8	.116	1/16	3/32



# CAPTIVE PANEL SCREWS—STYLE 6

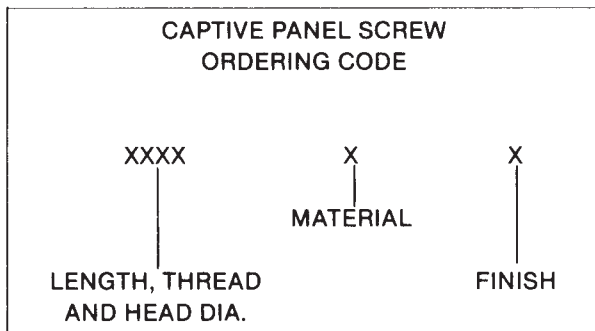
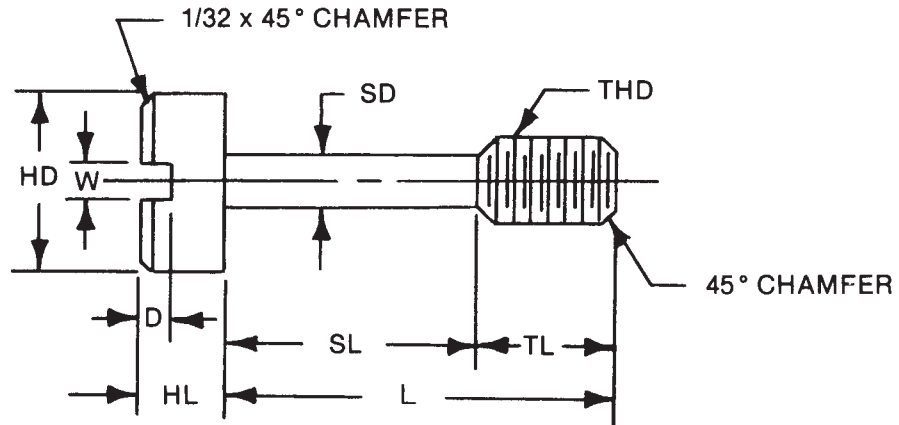

MATERIAL	CODE	RoHS
Brass	B	YES
Stainless Steel	SS	YES
Steel	S	YES

See page 9 for finish codes  
For non-standard parts contact Sales Office

Available with thread locking products, see page vii

PART NO.	THD.	H.D. ± .005	H.L. ± .010	L. + .010 - .005	T.L. ± .005	S.D. + .000 - .005	S.L. + .005 - .000	W. + .005 - .000	D. + .010 - .000
7083	4-40	1/4	1/8	15/32	3/16	.078	9/32	3/64	3/64
7084	4-40	1/4	1/8	17/32	3/16	.078	11/32	3/64	3/64
7085	6-32	9/32	1/8	17/32	7/32	.095	5/16	3/64	3/64
7086	6-32	9/32	1/8	19/32	7/32	.095	3/8	3/64	3/64
7087	6-32	9/32	1/8	21/32	7/32	.095	7/16	3/64	3/64
7088	8-32	5/16	5/32	21/32	1/4	.120	13/32	1/16	1/16
7089	8-32	5/16	5/32	23/32	1/4	.120	15/32	1/16	1/16
7090	8-32	5/16	5/32	25/32	1/4	.120	17/32	1/16	1/16
7091	10-32	3/8	3/16	27/32	5/16	.130	17/32	1/16	1/16
7092	10-32	3/8	3/16	29/32	5/16	.130	19/32	1/16	1/16



# MATERIALS

MATERIAL ROD & BAR	ORDERING CODE	MATERIAL SPECIFICATIONS	RoHS COMPLIANT
Aluminum	AL	QQ-A-225/3D, QQ-A-225/6A, QQ-A-225/8B, QQ-A-200/9D	YES
Brass	B	ASTM-B-16	YES
Nylon	N	LP-410A, D 4066	YES
Phenolic – Paper	PH	MIL-P-79 Type PBE, MIL-I-24768/10	YES
Phenolic – Linen	PHL	MIL-P-79 Type FBE, MIL-I-24768/13	YES
Steel	S	ASTM-A108-07	YES
Stainless Steel	SS	ASTM-A-581, A-582	YES
Teflon	TE	ASTM-1710	YES
Delrin	D	ASTM-D-4181	YES

\* Non RoHS Compliant Finish

## FINISH CODES

* 1	Cadmium (Commercial) (Special Order Only)	25	Black Oxide, Brass MIL-F-495E
* 2	Cadmium QQ-P-416F-Class 2 Type-1 (Clear Chromate) (Special Order Only)	26	Black Oxide, Stainless Steel, Steel Mil-DTL-13924D, Class 1 and 4
* 3	Cadmium QQ-P-416F-Class 2 Type-2 (Yellow Chromate) (Special Order Only)	27	Electro Tin Solder (60/40) per M222-MIL-F-14072D
4	Chrome Over Nickel	28	Zinc Plate .0002 ASTM-B-633 (Yellow Chromate)
5	Nickel QQ-N-290 Class 1 Grade G	29	Brushed Finish – Handles Only
* 6	Iridite #14 (Gold) MIL-DTL-5541F	30	Brushed Finish – Clear Lacquer – Handles Only
7	Iridite (Clear) MIL-DTL-5541F	31	Brushed Satin – Handles Only
* 9	Alodine 1200	32	Brushed Satin – Clear Anodize – Handles Only
10	Chrome QQ-C-320B Class 1 Type I (Bright Finish)	33	Brushed Satin – Black Anodize – Handles Only
11	Chrome QQ-C-320B Class 1 Type II (Satin Finish)	34	Satin Finish – Clear Anodize
12	Zinc .0002 ASTM-B-633 (Clear Chromate)	35	Satin Finish – Black Anodize
13	Bright Dip – Brass	36	Anodize MIL-A-8625F Black High Luster
14	Bright Tin ASTM B545 over Copper Flash Mil-C-14550	37	Ductile Nickel
15	Hot Tin Dip MIL-T-10727C Type II	38	Polished Nickel – Handles Only
16	Electro Tin ASTM B545 Class A, B or C	39	Caustic Etch and Lacquer
19	Caustic Etch	40	Semi-Frost Anodize (Clear)
20	Passivate MIL-F-14072E	41	Semi-Frost Anodize (Black)
21	Anodize MIL-A-8625F – Type II Class 2 (Sulfuric) Chemical Seal (Dark Grey)	42	Black Zinc
22	Anodize MIL-A-8625F – Type II Class 1 (Sulfuric) Hot Water Seal (Clear)	43	Blue Zinc
23	Anodize MIL-A-8625F – Type II Class 2 (Sulfuric) Chemical Seal (Yellow Green)	44	Electro Tin with Nickel Undercoat Per Mil-T-10727C
24	Anodize MIL-A-8625F – Type II Class 2 (Sulfuric) Chemical Seal (Black)	45	Passivate QQ-P-35C Type VI
		46	Passivate ASTM A 967 Nitric 1
		47	Passivate ASTM A 380-96
		48	Passivate AMS 2700 Type 2

## NOTES

Responsibility ends with customer inspection or 10 days after customer receives parts. No returns will be accepted without prior approval from factory in writing.

All parts are stocked in plain finish. Parts will be plated to customer specification.

The items in this catalog are designed and manufactured to be functional. Engineering evaluation and quality assurance evaluations should be accomplished with functionality as a prime criteria.

RAF reserves the right to change any specifications, tolerances and plating types, for any products listed in this REFERENCE MANUAL without prior notice, provided the function of the item is not changed.

All custom (non-catalog) items are subject to an over shipment or under shipment of up to 10% of the order quantity. The price quotation from RAF will clearly identify these items.

The following processes make threaded fasteners of all sizes and configurations self-locking and self-sealing. They can be used with both male and female threads and leave fasteners fully adjustable. The ND Patches are *Automotive and Military Approved*.

## ND PATCH®

### Locking, Sealing, Reusable, Factory Pre-Applied

The ND Patch is completely dry, fused to the fastener, and requires no curing time after installation.

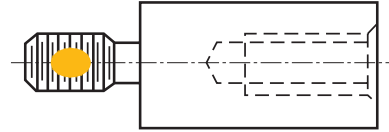

## ND 360° RING-PATCH®

### Locking, Sealing, Reusable, Factory Pre-Applied

The ND 360° Ring-Patch is completely dry, fused to the fastener, and requires no curing time after installation.

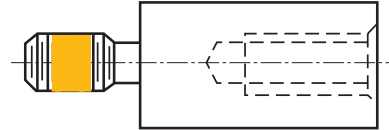

## ND PELL-IT®

### Locking, Sealing, Reusable, Factory Pre-Applied

The ND Pell-It is a special, tough nylon plug that is inserted into a drilled hole and makes any threaded fastener self-locking and self-sealing while leaving it fully adjustable. In addition to nylon, ND Pell-It is also available in KEL-F® and Vespel® for extremely high temperature applications.

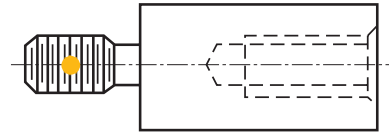

Two additional thread-locking products for your design needs:

## ND MICROSPHERES®

### Locking, Sealing, Bonding, Factory Pre-Applied

The micro-encapsulated adhesive market is no longer dominated by makers of expensive brand name products. ND Microspheres is an affordable, equivalent-quality alternative to brand name micro-encapsulated adhesives. It is offered in epoxy formulation, and is available *Pre-Applied*.

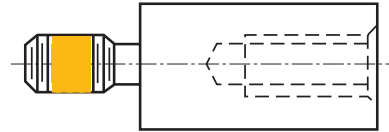

## ND VIBRA-TITE®

### Locking, Sealing, Re-Usable, Factory Pre-Applied, Minimizes Galling/Stripping

This low-cost blend of acrylic resins makes any threaded fastener self-locking and self-sealing, preventing it from loosening even under extreme vibration. Vibra-tite is available factory *Pre-Applied*. Once coated, the parts can be stored indefinitely before use. In addition, ND Vibra-tite is *Military Approved*.

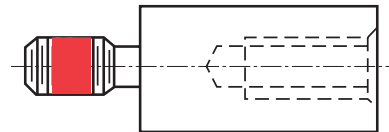

ND®, ND Patch®, ND 360° Ring-Patch®, ND Pell-It®, ND Microspheres®, and ND Vibra-tite® are all registered trademarks of ND Industries, Inc.

## Thread-locking products can be added to:

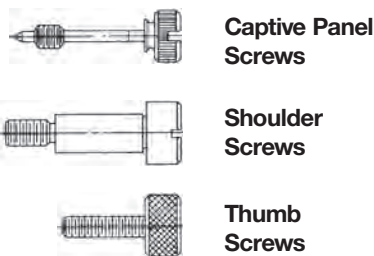
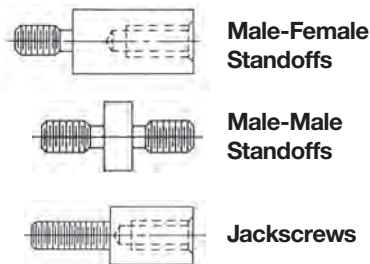

## How to order

Just add the appropriate thread-locking designation to our product number. Here's an example of ND PATCH added to a hex male-female standoff number:

**4500-440-SS-PL**

Thread-locking product designations

ND PATCH	PL
ND 360° RING PATCH	RP
ND PELL-IT	PI
ND MICROSPHERES	MS
ND VIBRA-TITE	VT