

Panduit Pre-Configured Physical Infrastructure for Cisco^ Unified Computing Systems (UCS)

The Cisco^ Unified Computing System (UCS) is a next-generation data center platform that unites compute, network, storage access, and virtualization into a cohesive system. Panduit's Pre-Configured Physical Infrastructures support the deployment of up to five UCS Blade Server Chassis within various cabinet footprints that optimize the physical infrastructure for the UCS server architectures. Three different cabinet widths are offered including:

- 32-inch version with Net-Access™ Cabinet that provides maximum room for cable management, POUs and easy access to serviceable parts such as cards, fans and power supplies
- 28-inch version with Net-SERV® Cabinet for customers seeking a balance between floor space and cable management area
- 24-inch version with Net-SERV® Cabinet maximizes floor space utilization for traditional deployments on raised floors. The trade-off for the narrower width is the reduction in space for cable management, and accessibility to the serviceable items



(32" Cisco^ UCS Pre-Configured Physical Infrastructure shown in a Net-Access™ Cabinet)



SFP+ Cables are available as an option for Cisco UCS Deployments

Part Number	Part Description	Std. Pkg. Qty.
CQ5108CS1B	Pre-Configured Physical Infrastructure for UCS Base with 32" wide Net-Access™ Cabinet and all necessary cable management, grounding jumpers, and patch panels pre-assembled together.	1
CQ5108S752B	Pre-Configured Physical Infrastructure for UCS Base with 28" wide Net-SERV® Cabinet and all necessary cable management, grounding jumpers, and patch panels pre-assembled together.	1
CQ5108S652B	Pre-Configured Physical Infrastructure for UCS Base with 24" wide Net-SERV® Cabinet and all necessary cable management, grounding jumpers, and patch panels pre-assembled together.	1

Cisco^ UCS Blade Servers not included in the part numbers above. Panduit Pre-Configured Physical Infrastructures are shipped on standard pallets. For applications that require shock-resistant packaging to facilitate pre-mounting of active electronics, please consult Panduit Customer Service.

^Cisco is a registered trademark of Cisco Technology Inc.

Panduit Pre-Configured Physical Infrastructure for the Cisco[^] Nexus 7010 Switch

The Cisco[^] Nexus 7010 Switch enables data center stakeholders to deploy a highly scalable 10 Gigabit Ethernet (GbE) network that supports virtualization technologies for consolidation of multiple applications over a smaller number of more powerful servers and switches. Panduit's Pre-Configured Physical Infrastructures support the deployment of Cisco[^] Nexus 7010 platforms with pre-assembled configurations that are offered in versions that meet typical copper and fiber line card provisioning schemes including:

- "Medium Fiber" for switch provisions requiring up to (4) 32-port fiber line cards
- "Medium Copper" for switch provisions requiring up to (4) 48-port copper line cards
- "Heavy Copper" for switch provisions requiring up to (6) 48-port copper line cards



(Nexus 7010 "Heavy Copper"
Pre-Configured Physical
Infrastructure shown)

Part Number	Part Description	Std. Pkg. Qty.
CQ7010CN1B	"Base" Pre-Configured Physical Infrastructure for Cisco [^] Nexus 7010 with Net-Access [™] Cabinet, and all necessary cable management, grounding jumpers, and patch panels pre-assembled together.	1
CQ7010CN1F4	"Medium Fiber" Pre-Configured Physical Infrastructure for Cisco [^] Nexus 7010 with Net-Access [™] Cabinet, and all necessary cable management, grounding jumpers, patch panels, and LC-LC patch cords (bulk packaged to accommodate 4 additional fiber line cards) pre-assembled together.	1
CQ7010CN1C4	"Medium Copper" Pre-Configured Physical Infrastructure for Cisco [^] Nexus 7010 with Net-Access [™] Cabinet, and all necessary cable management, grounding jumpers, patch panels, and copper CAT6 patch cords (bulk packaged to accommodate 4 additional copper line cards) pre-assembled together.	1
CQ7010CN1C6	"Heavy Copper" Pre-Configured Physical Infrastructure for Cisco [^] Nexus 7010 with Net-Access [™] Cabinet, and all necessary cable management, grounding jumpers, patch panels, and CAT6 patch cords (bulk packaged to accommodate 6 additional copper line cards) pre-assembled together.	1

Cisco[^] Nexus 7010 Switch not included in the part numbers above. Panduit Pre-Configured Physical Infrastructures are shipped on standard pallets. For applications that require shock-resistant packaging to facilitate pre-mounting of active electronics, please consult Panduit Customer Service.

[^]Cisco is a registered trademark of Cisco Technology Inc.

Panduit Pre-Configured Physical Infrastructure for the Cisco^ Catalyst 6509 Switch

The Cisco^ Catalyst 6509 Switch provides high port densities that are ideal for many wiring closet, distribution, and core network deployments. Panduit's Pre-Configured Physical Infrastructures support the deployment of the Cisco^ Nexus 6509 switch with pre-assembled configurations that are offered in versions that meet 10 GbE density copper and fiber line card provisioning schemes, including:

- "Medium Fiber" for switch provisions requiring up to (4) 32-port fiber line cards
- "Medium Copper" for switch provisions requiring up to (4) 48-port copper line cards
- "Heavy Copper" for switch provisions requiring up to (6) 48-port copper line cards



(Catalyst 6509 "Heavy Copper" Pre-Configured Physical Infrastructure shown)

Part Number	Part Description	Std. Pkg. Qty.
CQ6509CN1B	"Base" Pre-Configured Physical Infrastructure for Cisco^ Catalyst 6509 with Net-Access™ Cabinet, and all necessary cable management, grounding jumpers, and patch panels pre-assembled together.	1
CQ6509CN1F4	"Medium Fiber" Pre-Configured Physical Infrastructure for Cisco^ Catalyst 6509 with Net-Access™ Cabinet, and all necessary cable management, grounding jumpers, patch panels, and LC-LC patch cords (bulk packaged to accommodate 4 additional fiber line cards) pre-assembled together.	1
CQ6509CN1C4	"Medium Copper" Pre-Configured Physical Infrastructure for Cisco^ Catalyst 6509 with Net-Access™ Cabinet, and all necessary cable management, grounding jumpers, patch panels, and copper CAT6 patch cords (bulk packaged to accommodate 4 additional copper line cards) pre-assembled together.	1
CQ6509CN1C6	"Heavy Copper" Pre-Configured Physical Infrastructure for Cisco^ Catalyst 6509 with Net-Access™ Cabinet, and all necessary cable management, grounding jumpers, patch panels, and CAT6 patch cords (bulk packaged to accommodate 6 additional copper line cards) pre-assembled together.	1

Cisco^ Catalyst 6509 Switch not included in the part numbers above. Panduit Pre-Configured Physical Infrastructures are shipped on standard pallets. For applications that require shock-resistant packaging to facilitate pre-mounting of active electronics, please consult Panduit Customer Service.

^Cisco is a registered trademark of Cisco Technology Inc.

Panduit Pre-Configured Physical Infrastructure for the Cisco[^] Nexus 7009 Switch



(Nexus 7009 "Heavy Copper"
Pre-Configured Physical
Infrastructure shown)

The Cisco[^] Nexus 7009 Switch enables data center stakeholders to deploy a highly scalable 10 Gigabit Ethernet (GbE) network that supports virtualization technologies for consolidation of multiple applications over a smaller number of more powerful servers and switches. All cabinet versions of Panduit pre-configured offerings for the Nexus 7009 include newly designed intake duct to optimize cooling airflow.

Panduit Pre-Configured Physical Infrastructures support the deployment of Cisco[^] Nexus 7009 Switch platforms with pre-assembled configurations that are offered in versions that meet typical copper and fiber line card provisioning schemes including:

- "Medium Fiber" for switch provisions requiring up to (4) 32-port fiber I/O Modules
- "Medium Copper" for switch provisions requiring up to (4) 48-port copper I/O Modules
- "Heavy Copper" for switch provisions requiring up to (6) 48-port copper I/O Modules

Item	Part Description	Std. Pkg. Qty.
CQ7009CN01	"Base" Pre-Configured Physical Infrastructure for Cisco [^] Nexus 7009 with Net-Access™ Cabinet and intake ducting, as well as all necessary cable management, grounding jumpers, and patch panels.	1
CQ7009CN02	"Medium Fiber" Pre-Configured Physical Infrastructure for Cisco [^] Nexus 7009 with Net-Access™ Cabinet and intake ducting, as well as all necessary cable management, grounding jumpers, patch panels, and MTP-LC Hydra cable assemblies (bulk packaged to accommodate four fiber I/O Modules).	1
CQ7009CN03	"Medium Copper" Pre-Configured Physical Infrastructure for Cisco [^] Nexus 7009 with Net-Access™ Cabinet and intake ducting, as well as all necessary cable management, grounding jumpers, patch panels, and copper Category 6A patch cords (bulk packaged to accommodate four copper I/O Modules).	1
CQ7009CN04	"Heavy Copper" Pre-Configured Physical Infrastructure for Cisco [^] Nexus 7009 with Net-Access™ Cabinet and intake ducting, as well as all necessary cable management, grounding jumpers, patch panels, and copper Category 6A patch cords (bulk packaged to accommodate six copper I/O Modules).	1

Cisco[^] Nexus 7009 Switch not included in the part numbers above. Panduit Pre-Configured Physical Infrastructures are shipped on standard pallets. For applications that require shock-resistant packaging to facilitate pre-mounting of active electronics, please consult Panduit Customer Service.

[^]Cisco is a registered trademark of Cisco Technology Inc.



Net-Access™ Cabinet System

Thermal Management and Cable Capacity for Switch and Server Applications

Net-Access™ Cabinets are the first choice for switch, server, and storage area network applications that require maximum thermal management capability, and the capacity to manage high cable densities.

Net-Access™ Switch Cabinet features include:

- In-cabinet ducting solutions to enable optimized airflow of switches with side-to-side airflow
- Large vertical pathways for high cable count applications
- Cable management fingers mount to front and back posts for maximum cabling configurations
- Dual hinge door for maximum accessibility between adjacent cabinets

Net-Access™ Server Cabinet features and options include:

- Vertical exhaust duct for optimal thermal performance
- Provides maximum cable management area and thermal performance
- Vertical patch panel configuration provides up to eight additional rack units in the same footprint
- Utilizes same platform as switch cabinet to enable maximum flexibility and deployment options



Net-Access™ Switch Cabinets are compatible with Cisco^ Nexus 7018, MDS9500 Series, and 6500 Series Switches. Go to www.panduit.com/cisco1 for disclaimer.

Nexus 7018 and 7010 Applications are supported by Application Guides/Notes available at panduit.com.

^Cisco is a registered trademark of Cisco Technology, Inc.



Net-Access™ Cabinet Applications



UCS
Server

Nexus
7018

Nexus
7010

MDS
9513

Catalyst
6509



Net-Access™ Switch Cabinets are compatible with Cisco^ Nexus 7018, MDS9500 Series, and 6500 Series Switches. Go to www.panduit.com/cisco1 for disclaimer.

Nexus 7018 and 7010 Applications are supported by Application Guides/Notes available at panduit.com.

^Cisco is a registered trademark of Cisco Technology, Inc.



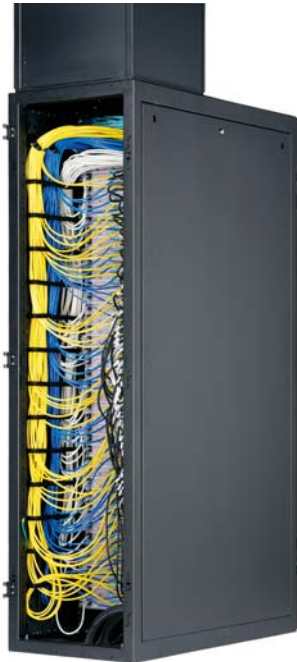

Net-SERV® Cabinet System

Optimized Thermal and Cable Management for Server Applications

Net-SERV® Cabinets provide thermal and cable management to accommodate low to high-density server deployments. Vertical exhaust ducting can be used to optimize airflow, reducing energy costs by up to 25%. Air sealing accessories prevent leaks and improve the utilization of cooling air.

High Density Server Configuration:

- 600mm (24") or 700mm (28") widths
- High density solution provides four separate vertical pathways and modular L-rings with bend radius control for optimum cable routing
- Organizes data and power cables in segregated channels away from server exhaust for unobstructed airflow
- Vertical exhaust duct configuration available

Vertical Patch Cable Management Configuration:

- 700mm (28") width
- Vertical patch panel solution provides up to four additional rack units in the same footprint
- Maximizes rack space utilization for additional servers and other devices
- Positions network connections in the optimum location allowing the use of single length patch cords
- Supplied with cable management fingers at each rack unit to manage data and power cables



Standard Density Server Configuration:

- 600mm (24") or 700mm (28") widths
- Provides cable management fingers at each rack unit to manage data and power cables

Net-Access™ Switch Cabinets Roadmap

Manages, protects, and showcases your network by combining the aesthetics and security of a cabinet with the accessibility of an open rack

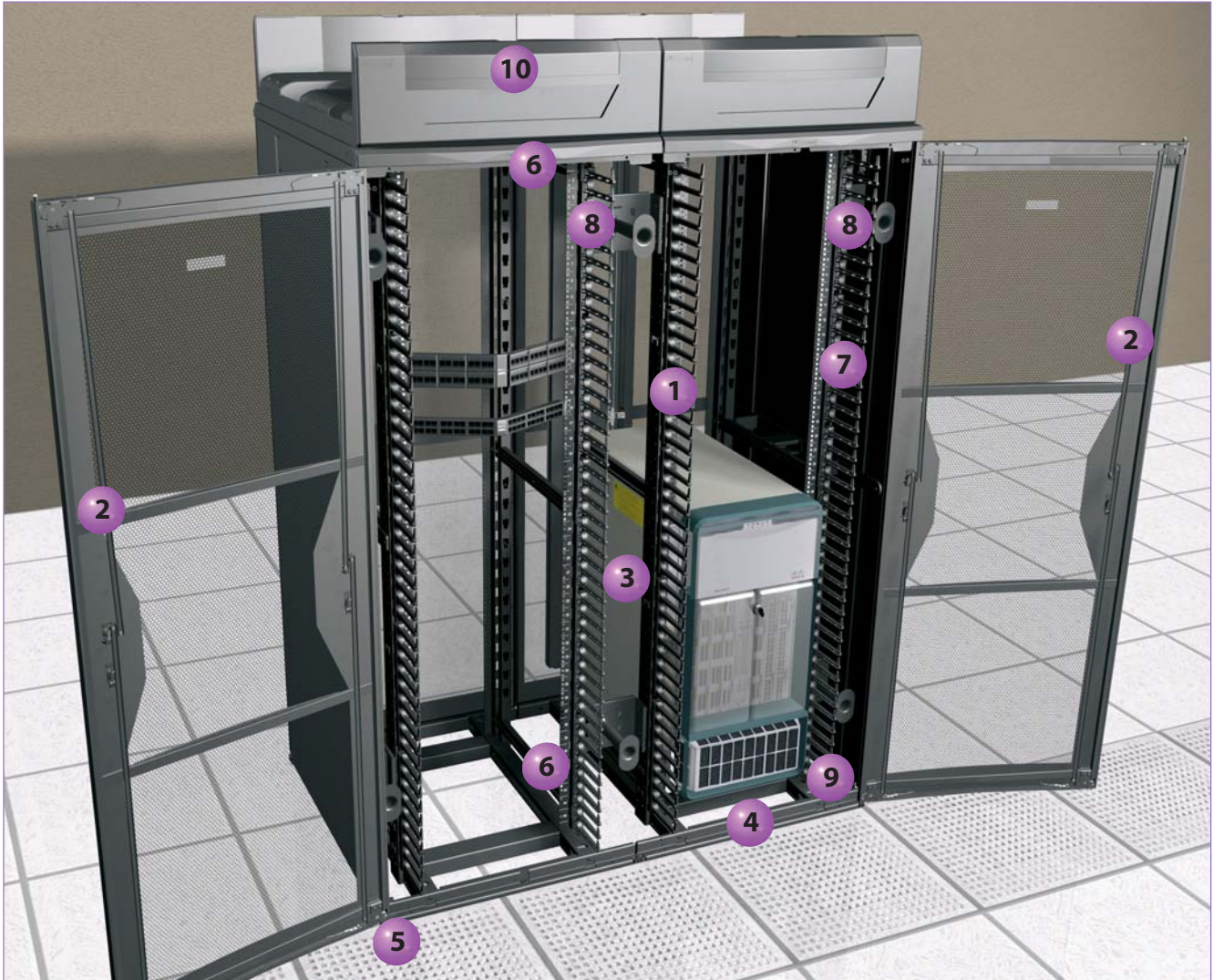

Net-Access™ Switch Cabinets have tested compatible with Cisco Nexus 7018, MDS 9513, and Catalyst 6509.

Request Info



1-800-453-1692

www.aboveboardelectronics.com

Net-Access™ Switch Cabinets Roadmap (continued)

1 Cable Management – Vertical cable pathway design is optimized to provide unobstructed access; cable management finger sections can be located where needed on all four posts and align with rack spaces to ensure proper bend radius control



6 Routing Options for Overhead and Underfloor Cabling – Knockouts in the top allow multiple options for overhead cable routing; large bottom openings provide pathways for routing cables from underfloor

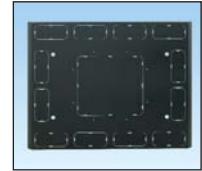

2 Dual Hinged Door – Door can be opened 180° to left or right enabling unobstructed access to adjacent cabinets and pathways



7 Adjustable Equipment Rails – Front and rear rails are fully adjustable to accommodate a variety of equipment and have printed rack space identification

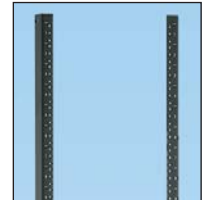

3 Thermal Management – Inset frame posts and cable management ensure clear pathways to provide proper heat dissipation; optional air ducts provide exhaust channels for high heat density applications



8 Optional Slack Spools – Slack management spools organize and manage patch cord slack; spools are available in side mount for single cabinet or center mount for ganged application



4 Grounding and Bonding – Entire cabinet is fully electrically bonded including equipment rails, doors and side panels; when combined with StructuredGround™ Grounding System, promotes protection of equipment and personnel



9 Cool Boot® Raised Floor Air Sealing Grommet – The raised floor air sealing grommet reduces bypass airflow and prevents debris from falling below the raised floor; grommets are available in different sizes for a variety of applications



5 Easily Accessible Casters and Leveling Legs – Leveling legs can be safely and easily adjusted and can retract into the cabinet frame; optional casters mount to side of posts for safe, easy field installation



10 Versatile Cable Routing – The CabRunner® Overhead Cable Routing System is a high capacity data cable pathway used directly over the Net-Access™ Cabinets; eliminates the need for multiple infrastructure elements, reducing installation time



Cable Capacity Chart

Channel	No Slack Spool							With Slack Spool						
	Channel Area		Cable Capacity*					Channel Area		Cable Capacity*				
	In. ²	cm ²	Cat. 6A SD (0.240")	Cat. 6A (0.300")	Cat. 6 (0.240")	Cat. 5e (0.225")	Fiber (3mm)	In. ²	cm ²	Cat. 6A SD (0.240")	Cat. 6A (0.300")	Cat. 6 (0.240")	Cat. 5e (0.225")	Fiber (3mm)
End	42.2	272.3	373	238	373	424	1,540	32.4	209.0	286	183	286	325	1,182
Center (ganged)	84.4	544.5	746	477	746	849	3,081	74.6	481.3	659	422	659	750	2,723

*Note: Capacities are based upon a fill rate of 40% to accommodate proper cable routing applications. All dimensions represent typical outer cable diameter in inches.

Net-Access™ Switch Cabinets

- Inset frame posts create large and accessible vertical pathways for routing cables
- Modular cable management fingers easily mount to the front and/or back of all four cabinet posts
- Designed with the use of CFD (computational fluid dynamics) analysis and thermal lab testing to optimize the thermal performance of network switches requiring side-to-side airflow
- Accommodate equipment mounting depths up to 25.9" (658mm)
- Innovative, fully integrated, electrically bonded cabinet with a single ground connection to guard against EMI and ESD, and provide a safe current path to ground

- Four adjustable equipment mounting rails – available in cage nut or #12-24 threaded with printed rack space identification
- Equipment rails have printed rack space numbering that can be oriented numbers up or down
- Durable black polyester epoxy powder coat finish
- 2,500 lbs. (1134 kg) load rating
- Cabinet ships assembled, one per pallet
- For the complete grounding solution, see the StructuredGround™ Kits for Cabinets selection guide on pages M.10 – M.11



CN1



CN2

Part Number	Part Description	Std. Pkg. Qty.
Net-Access™ 45 RU Switch Cabinets for Use in Hot Aisle/Cold Aisle Applications		
CN1	Cabinet frame with top panel. Tapped equipment rails (12-24). Dual hinge perforated front door opens to the left or right. Split perforated rear doors open in the middle to minimize door swing footprint. Solid side panels. (2) Two sets of #12-24 threaded equipment mounting rails. 45 RU cable management on front and rear of front posts. Dimensions: 84.0"H x 31.5"W x 41.1"D (2134mm x 800mm x 1044mm)	1
CN1NU	Cabinet frame with top panel. Tapped equipment rails (12-24). Dual hinge perforated front door opens to the left or right. Split perforated rear doors open in the middle to minimize door swing footprint. Solid side panels. (2) Two sets of #12-24 threaded equipment mounting rails – mounted numbers up. 45 RU cable management on front and rear of front posts. Dimensions: 84.0"H x 31.5"W x 41.1"D (2134mm x 800mm x 1044mm)	1
CN1CN	Cabinet frame with top panel. Cage nut rails (12-24). Dual hinge perforated front door opens to the left or right. Split perforated rear doors open in the middle to minimize door swing footprint. Solid side panels. (2) Two sets of #12-24 cage nut equipment mounting rails. 45 RU cable management on front and rear of front posts. Dimensions: 84.0"H x 31.5"W x 41.1"D (2134mm x 800mm x 1044mm)	1
CN1CNU	Cabinet frame with top panel. Cage nut rails (12-24) – mounted numbers up Dual hinge perforated front door opens to the left or right. Split perforated rear doors open in the middle to minimize door swing footprint. Solid side panels. (2) Two sets of #12-24 cage nut equipment mounting rails – numbered up. 45 RU cable management on front and rear of front posts. Dimensions: 84.0"H x 31.5"W x 41.1"D (2134mm x 800mm x 1044mm)	1
CN1CNU	Cabinet frame with top panel. Split perforated front and rear doors open in the middle to minimize door swing footprint. Solid side panels. (2) Front cage nut equipment mounting rails – mounted numbers up. Rear extended cage nut equipment mounting rails – mounted numbers up. 29.0" rail span. 45 RU cable management on front and rear of front posts. Dimensions: 84.0"H x 31.5"W x 41.1"D (2134mm x 800mm x 1044mm)	1
CN2	Cabinet frame with top panel. Dual hinge perforated front door opens to the left or right. Split perforated rear doors open in the middle to minimize door swing footprint. Two sets of #12-24 threaded equipment mounting rails. 45 RU cable management on front and rear of front posts. Dimensions: 84.0"H x 31.5"W x 41.1"D (2134mm x 800mm x 1044mm)	1

White cabinets also available upon request. Please consult Panduit Customer Service for lead-times.

Net-Access™ Switch Cabinets (continued)



CN3



CN4



CN5

Part Number	Part Description	Std. Pkg. Qty.
CN2NU	Cabinet frame with top panel. Dual hinge perforated front door opens to the left or right. Split perforated rear doors open in the middle to minimize door swing footprint. Two sets of #12-24 threaded equipment mounting rails – numbered up. 45 RU cable management on front and rear of front posts. Dimensions: 84.0"H x 31.5"W x 41.1"D (2134mm x 800mm x 1044mm)	1
CN2CN	Cabinet frame with top panel. Cage nut rails (12-24). Dual hinge perforated front door opens to the left or right. Split perforated rear doors open in the middle to minimize door swing footprint. Two sets of #12-24 cage nut equipment mounting rails. 45 RU cable management on front and rear of front posts. Dimensions: 84.0"H x 31.5"W x 41.1"D (2134mm x 800mm x 1044mm)	1
CN2CNU	Cabinet frame with top panel. Cage nut rails (12-24) – mounted numbers up. Dual hinge perforated front door opens to the left or right. Split perforated rear doors open in the middle to minimize door swing footprint. Two sets of #12-24 cage nut equipment mounting rails – numbered up. 45 RU cable management on front and rear of front posts. Dimensions: 84.0"H x 31.5"W x 41.1"D (2134mm x 800mm x 1044mm)	1
CN2CNU	Cabinet frame with top panel. Dual hinge perforated front door opens to the left or right. Split perforated rear doors open in the middle to minimize door swing footprint. Front cage nut equipment mounting rails – mounted numbers up. Rear extended cage nut equipment mounting rails – mounted numbers up. 29.0" rail span. 45 RU cable management on front and rear of front posts. Dimensions: 84.0"H x 31.5"W x 41.1"D (2134mm x 800mm x 1044mm)	1
CN2C	Cabinet frame with top panel. Dual hinge perforated front door opens to the left or right. Split perforated rear doors open in the middle to minimize door swing footprint. Front cage nut equipment mounting rails – mounted numbers up. Rear extended cage nut equipment mounting rails – mounted numbers up. 29" rail span. 45 RU cable management on front and rear of front posts. Dimensions: 84.0"H x 31.5"W x 41.1"D (2134.0mm x 800.0mm x 1044.0mm)	1
CN3	Cabinet frame with top panel. Two sets of #12-24 threaded equipment mounting rails. 45 RU cable management on front and rear of front posts. Dimensions: 84.0"H x 31.5"W x 40.0"D (2134mm x 800mm x 1016mm)	1
CN3CN	Cabinet frame with top panel. Two sets of #12-24 cage nut equipment mounting rails. 45 RU cable management on front and rear of front posts. Dimensions: 84.0"H x 31.5"W x 40.0"D (2134.0mm x 800.0mm x 1016.0mm)	1
CN3CNU	Cabinet frame with top panel. Cage nut rails (12-24) – mounted numbers up. Two sets of #12-24 cage nut equipment mounting rails – numbered up. 45 RU cable management on front and rear of front posts. Dimensions: 84.0"H x 31.5"W x 40.0"D (2134mm x 800mm x 1044mm)	1
CN3CNU	Cabinet frame with top panel. Front cage nut equipment mounting rails – mounted numbers up. Rear extended cage nut equipment mount rails – mounted numbers up. 29" rail span. 45 RU cable management on front and rear of front posts. Dimensions: 84.0"H x 31.5"W x 40.0"D (2134mm x 800mm x 1016mm)	1
CN3C	Cabinet frame with top panel. Front cage nut equipment mounting rails – mounted numbers up. Rear extended cage nut equipment rails – mounted numbers up. 29" rail span. 45 RU cable management on front and rear of front posts. Dimensions: 84.0"H x 31.5"W x 40.0"D (2134.0mm x 800.0mm x 1044.0mm)	1
CN4	Cabinet frame with top panel. Split perforated front and rear doors open in the middle to minimize door swing footprint. Solid side panels. (2) Set of two #12-24 threaded equipment mounting rails. 45 RU cable management on front and rear of front posts. Dimensions: 84.0"H x 31.5"W x 40.0"D (2134mm x 800mm x 1017mm)	1

White cabinets also available upon request. Please consult Panduit Customer Service for lead-times.

Table continues on page L.14

**Net-Access™ Switch Cabinets (continued)**

Part Number	Part Description	Std. Pkg. Qty.
CN4C	Cabinet frame with top panel. Split perforated front and rear doors open in the middle to minimize door swing footprint. Solid side panels. (2) Front cage nut equipment mounting rails. Rear extended cage nut equipment rails provide overall rail span of 29" (736mm). 45 RU cable management on front and rear of front posts. Dimensions: 84.0"H x 31.5"W x 40.0"D (2134mm x 800mm x 1017mm)	1
CN5	Cabinet frame with top panel. Split perforated front and rear doors open in the middle to minimize door swing footprint. Set of two #12-24 threaded equipment mounting rails. 45 RU cable management on front and rear of front posts. Dimensions: 84.0"H x 31.5"W x 40.0"D (2134mm x 800mm x 1044mm)	1
CN5C	Cabinet frame with top panel. Split perforated front and rear doors open in the middle to minimize door swing footprint. Front cage nut equipment mounting rails. Rear extended cage nut equipment rails provide overall rail span of 29" (736mm). 45 RU cable management on front and rear of front posts. Dimensions: 84.0"H x 31.5"W x 40.0"D (2134mm x 800mm x 1044mm)	1

**CN12NU****Net-Access™ 42 RU Switch Cabinets for Use in Hot Aisle/Cold Aisle Applications**

CN12NU	42 available rack spaces. Cabinet frame with top panel. Dual hinge perforated front door opens to the left or right. Split perforated rear doors open in the middle to minimize door swing footprint. Solid side panels (2). Two sets of #12-24 threaded equipment mounting rails – mounted numbers up. 42 RU cable management on front and rear of front posts. Dimensions: 78.8"H x 31.5"W x 41.1"D (2000mm x 800mm x 1044mm)	1
CN22NU	42 available rack spaces. Cabinet frame with top panel. Dual hinge perforated front door opens to the left or right. Split perforated rear doors open in the middle to minimize door swing footprint. Two sets of #12-24 threaded equipment mounting rails – mounted numbers up. 42 RU cable management on front and rear of front posts. Dimensions: 78.8"H x 31.5"W x 41.1"D (2000mm x 800mm x 1044mm)	1
CN42NU	42 available rack spaces. Cabinet frame with top panel. Split perforated front and rear doors open in the middle to minimize door swing footprint. Solid side panels (2). Set of two #12-24 threaded equipment mounting rails – mounted numbers up. 42 RU cable management on front and rear of front posts. Dimensions: 84.0"H x 31.5"W x 40.0"D (2134mm x 800mm x 1017mm)	1
CN12CNNU	42 available rack spaces. Cabinet frame with top panel. Dual hinge perforated front door opens to the left or right. Split perforated rear doors open in the middle to minimize door swing footprint. Solid side panels (2). Two sets of cage nut equipment rails – mounted numbers up. 42 RU cable management on front and rear of front posts. Dimensions: 78.8"H x 31.5"W x 41.1"D (2000mm x 800mm x 1044mm)	1
CN22CNNU	42 available rack spaces. Cabinet frame with top panel. Dual hinge perforated front door opens to the left or right. Split perforated rear doors open in the middle to minimize door swing footprint. Two sets of cage nut equipment rails – mounted numbers up. 42 RU cable management on front and rear of front posts. Dimensions: 78.8"H x 31.5"W x 41.1"D (2000mm x 800mm x 1044mm)	1

White cabinets also available upon request. Please consult Panduit Customer Service for lead-times.



Net-Access™ Switch Cabinets (continued)

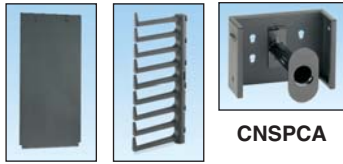

CNPS CNBRFK



CNSPE CNCSTR

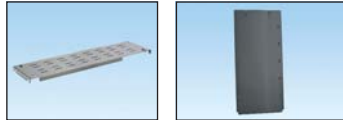

CSBA CNPSPT



CNPP CNFBB CNFBB4R

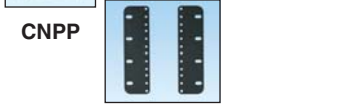

CNFBBS

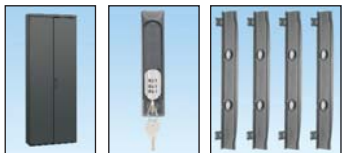

CVED32 CCL CNVBP
CNVBP2

Part Number	Part Description	Std. Pkg. Qty.
Net-Access™ Switch Cabinet Options and Accessories		
CNPS	Removable solid side panel with lockable push button latches.	1
CNBRFK	Network cabinet cable management finger kit, nine RU sections. Kit includes five left and five right finger sections to complete 45 RU on one side of post.	1
CNSPCA	Network cabinet center channel slack spool. Package includes one center spool and mounting bracket.	1
CNSPE	Net-Access™ Network Cabinet and 4 post rack end channel slack spools. Package includes one left and one right slack spool and mounting brackets.	1
CNCSTR	Network cabinet casters – set of four. Can be field installed without tipping cabinet. Adds 1.7" (43mm) to cabinet height.	1
CSBA	Network cabinet adjustable cable support bridge supports horizontal cable runs between Net-Access™ Cabinets.	1
CNPSPT	Removable side panel with pass-through holes and lockable push button latches.	1
CNPP	Removable cabinet perforated side panel with lockable push button latches.	1
CNFBB	Side cabinet cable management bracket for side mounting 19" EIA equipment.	1
CNFBB4R	Side cable management for mounting 19" EIA equipment, 4 RU. Comes with bend radius clips.	1
CNFBBS	Side cabinet bracket for mounting 19" EIA equipment.	1
CVED32	Vertical exhaust cabinet extension and solid rear split doors. Leveling legs and gasket kit included.	1
CCL	The cabinet combination lock is a 3 digit combination lock that can be installed on any Net-Access™ or Net-SERV® Cabinet dual hinge, single hinge or split door. This combination lock easily replaces the standard door handles. The 3 digit combination easily changes from the factory setting to a custom code. The lock also includes an integrated keyed override that is master-keyable.	1
CNVBP	45 RU Net-Access™ Switch Cabinet Vertical Blanking Panels with pass-through holes.	1
CNVBP2	42 RU Net-Access™ Switch Cabinet Vertical Blanking Panels with pass-through holes.	1
CNWS1224-C	#12-24 cage nut and screws.	100

Cisco^ Nexus 7018 Cabinet Solution

- Engineered to provide a best in class solution for Cisco Nexus 7018 switches
- Available for multiple architectures including: hot aisle/cold aisle applications, cold aisle containment applications, and vertical exhaust duct applications
- Offered in both 42 RU and 45 RU heights to meet your data center's height requirement
- Inlet duct, exhaust duct or vertical blanking panels are preinstalled on the cabinet
- Cabinet ships assembled, one per pallet



Net-Access™
7018 Cabinets

Part Number	Part Description	Std. Pkg. Qty.
-------------	------------------	----------------

Net-Access™ 42 RU and 45 RU 7018 Cabinets for Use in Hot Aisle/Cold Aisle Applications

CN3847018NU	Net-Access™ Network Cabinet for 7018 switch, 45 RU, #12-24 threaded rails, numbers up, intake and exhaust ducts, and cable management fingers. Dimensions: 39.5"W x 48.0"D x 84"H (1003mm x 1219mm x 2134mm)	1
CN5847018NU	Net-Access™ Network Cabinet for 7018 switch, 45 RU, #12-24 threaded rails, numbers up, split perforated front door, split perforated rear door, intake and exhaust ducts, and cable management fingers. Dimensions: 39.5"W x 48.9"D x 84"H (1003mm x 1242mm x 2134mm)	1
CN4847018NU	Net-Access™ Network Cabinet for 7018 switch, 45 RU, #12-24 threaded rails, numbers up, split perforated front door, split perforated rear door, side panels (2), intake and exhaust ducts, and cable management fingers. Dimensions: 39.5"W x 48.9"D x 84"H (1003mm x 1242mm x 2134mm)	1
CN48470182NU	Net-Access™ Network Cabinet for 7018 switch, 42 RU, #12-24 threaded rails, numbers up, split perforated front door, split perforated rear door, side panels (2), intake and exhaust ducts, and cable management fingers. Dimensions: 39.5"W x 48.9"D x 78.8"H (1003mm x 1242mm x 2000mm)	1
CN5847018CNUU	Net-Access™ Network Cabinet for 7018 switch, 45 RU, perforated split doors, no side panels, 7018 inlet and exhaust ducting, cage nut rails – mounted numbers up. Dimensions: 39.5"W x 48.9"D x 84.0"H (1003mm x 1242mm x 2134mm)	1

Net-Access™ 42 RU and 45 RU 7018 Cabinets for Use in Cold Aisle Containment Applications

CN484C7018NU	Net-Access™ Network Cabinet for 7018 switch, 45 RU, #12-24 threaded rails, numbers up, split perforated front door, split perforated rear door, side panels, intake duct, vertical blanking panels, and cable management fingers. Dimensions: 39.5"W x 48.9"D x 84"H (1003mm x 1242mm x 2134mm)	1
CN484C70182CNUU	Net-Access™ Network Cabinet for 7018 switch, 42 RU, perforated split doors, side panels (2), vertical blanking panels, 7018 inlet ducting, and cage nut rails – mounted numbers up. Dimensions: 39.5"W x 48.9"D x 78.8"H (1003mm x 1242mm x 2000mm)	1

Net-Access™ 45 RU 7018 Cabinets Vertical Exhaust Ready

CN584H7018	Net-Access™ Network Cabinet for 7018 switch, 45 RU, #12-24 threaded rails, numbers up, split perforated front door, solid split rear door, chimney ready top cap, intake duct, vertical blanking panels, and cable management fingers. Dimensions: 39.5"W x 48.9"D x 84"H (1003mm x 1242mm x 2134mm)	1
------------	---	---

Vertical Exhaust Ducting for VED Ready 7018 Cabinets

CVED40VE	Vertical exhaust duct for Net-Access™ 7018 cabinet, height adjustable from 42.0"(1067mm) to 70.0" (1778mm).	1
CVED40VEN	Vertical exhaust duct for Net-Access™ 7018 cabinet, height adjustable from 21.0"(534mm) to 45.0" (1143mm).	1



CVED40VE

^Cisco is a registered trademark of Cisco Technology, Inc.

White cabinets also available upon request. Please consult Panduit Customer Service for lead-times.

Net-Access™ Extended Switch Cabinets Recommended for Cisco^ Nexus 7010 Switch

- Engineered to provide a best in class solution for Cisco^ Nexus 7010 switches
- Offered in both 42 RU and 45 RU heights to meet your data center's height requirement
- 31.5"W x 48"D (800mm x 1219mm) Frame
- Cabinet ships assembled, one per pallet



Net-Access™
7010 Cabinets

Part Number	Part Description	Std. Pkg. Qty.
-------------	------------------	----------------

Net-Access™ 42 RU and 45 RU Extended Switch Cabinets for Use in Hot Aisle/Cold Aisle Applications

CN18NU	Net-Access™ Extended Switch Cabinet, front dual hinge door, rear split doors, (2) side panels, #12-24 tapped equipment rails mounted numbers up. Dimensions: 31.5"W x 48.9"D x 84.0"H (800mm x 1242mm x 2134mm) 45 RU	1
CN182CNU	Net-Access™ Extended Switch Cabinet, front dual hinge door, rear split doors (2) cage nut equipment rails – mounted numbers up. Dimensions: 31.5"W (800mm) x 48.9"D (1242mm) x 78.8"H (2000mm) 42 RU	1
CN28	Net-Access™ Extended Switch Cabinet, front dual hinge door, rear perforated split doors, no side panels, #12-24 rails. Dimensions: 31.5"W x 48.9"D x 84"H (800mm x 1242mm x 2134mm) 45 RU	1
CN28NU	Net-Access™ Extended Switch Cabinet, front dual hinge door, rear perforated split doors, no side panels, #12-24 rails – mounted numbers up. Dimensions: 31.5"W x 48.9"D x 84.0"H (800mm x 1242mm x 2134mm) 45 RU	1
CN28CNU	Net-Access™ Extended Switch Cabinet, front dual hinge door, rear split doors, no side panels, cage nut equipment rails mounted numbers up. Dimensions: 31.5"W x 48.9"D x 84.0"H (800mm x 1242mm x 2134mm) 45 RU	1
CN28CNU	Net-Access™ Extended Switch Cabinet, single perforated front door, split perforated rear doors, front cage nut equipment mounting rails – mounted numbers up, rear extended cage nut equipment mounting rails create a 29.0" mounting range and cable management on front and rear of front posts. Dimensions: 31.5"W x 48.0"D x 84.0"H (800mm x 1219mm x 2134mm) 45 RU	1
CN348	Net-Access™ Extended Switch Cabinet, no doors, no side panels. #12-24 rails. Dimensions: 31.5"W x 48"D x 84"H (800mm x 1219mm x 2134mm) 45 RU	1

Net-Access™ 42 RU and 45 RU Extended Switch Cabinets for Use in Cold Aisle Containment Applications

CN28BNU	Net-Access™ Extended Switch Cabinet, front dual hinge door, rear perforated split doors, no side panels, vertical blanking panels, #12-24 rails – mounted numbers up. Dimensions: 31.5"W x 48.9"D x 84"H (800mm x 1242mm x 2134mm) 45 RU	1
CN28BCNU	Net-Access™ Extended Switch Cabinet, front dual hinge door, rear perforated split doors, no side panels, vertical blanking panels, cage nut rails – mounted numbers up. Dimensions: 31.5"W x 48.9"D x 84.0"H (800mm x 1242mm x 2134mm) 45 RU	1

^Cisco is a registered trademark of Cisco Technology, Inc.
White cabinets also available upon request. Please consult Panduit Customer Service for lead-times.

Table continues on page L.18

**Net-Access™ Extended Switch Cabinets Recommended for
Cisco^ Nexus 7010 Switch (continued)**

Part Number	Part Description	Std. Pkg. Qty.
CN28BLNU	Net-Access™ Extended Switch Cabinet, front dual hinge door, rear perforated split doors, (1) side panel – left side, vertical blanking panels, #12-24 rails – mounted numbers up. Dimensions: 31.5"W x 48.9"D x 84"H (800mm x 1242mm x 2134mm) 45 RU	1
CN28BLCNNU	Net-Access™ Extended Switch Cabinet, front dual hinge door, rear perforated split doors, (1) side panel – left side, vertical blanking panels, cage nut rails – mounted numbers up. Dimensions: 31.5"W x 48.9"D x 84"H (800mm x 1242mm x 2134mm) 45 RU	1
CN282BCNNU	Net-Access™ Extended Switch Cabinet, front dual hinge door, rear perforated split doors, cage nut rails (2) – mounted numbers up. 42 RU cable management on front and rear of front posts. Dimensions: 31.5"W x 48.9"D x 78.8" (800mm x 1242mm x 2000mm)	1

Net-Access™ 45 RU Extended Switch Cabinets for Use in Vertical Exhaust Duct Applications

CN28HBNU	Net-Access™ VED Cabinet, front dual hinge door, rear solid split door, high flow top cap vertical blanking panels, #12-24 rails – mounted numbers up. Dimensions: 31.5"W x 48.9"D x 84"H (800mm x 1242mm x 2134mm) 45 RU	1
CN28HBCNNU	45 RU, 800 Wide x 1200 Deep - Vertical Exhaust Duct Switch cabinet, no side panels, vertical blanking panels, cage nut equipment rails – mounted numbers up	1

Net-Access™ Vertical Exhaust Duct

CVED32VE	Variable duct extension is infinitely adjustable between 42.0" (1067mm) to 70.0" (1778mm).	1
CVED32VES	Variable short duct extension is infinitely adjustable between 20.0" (508mm) to 36.0" (914mm).	1

Net-Access™ 7010 Switch Cabinet Accessories

CVPDUB48	Bracket for vertical POU mounting to the side of the Net-Access™ 32" x 48" Cabinet rear extension (kit of two).	1
-----------------	---	---

^Cisco is a registered trademark of Cisco Technology, Inc.
White cabinets also available upon request. Please consult Panduit Customer Service for lead-times.

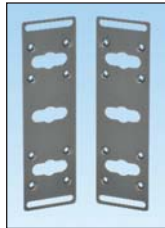
**CVED32VE****CVPDUB48**

Net-Access™ Server Cabinet System Roadmap

The Net-Access™ Server Cabinet provides scalable thermal management for low to high heat density applications. Superior cable management eliminates cable and power cord congestion behind the servers allowing server fans to more efficiently exhaust air from the cabinet. Air blocking features ensure that cold air is directed to the servers.

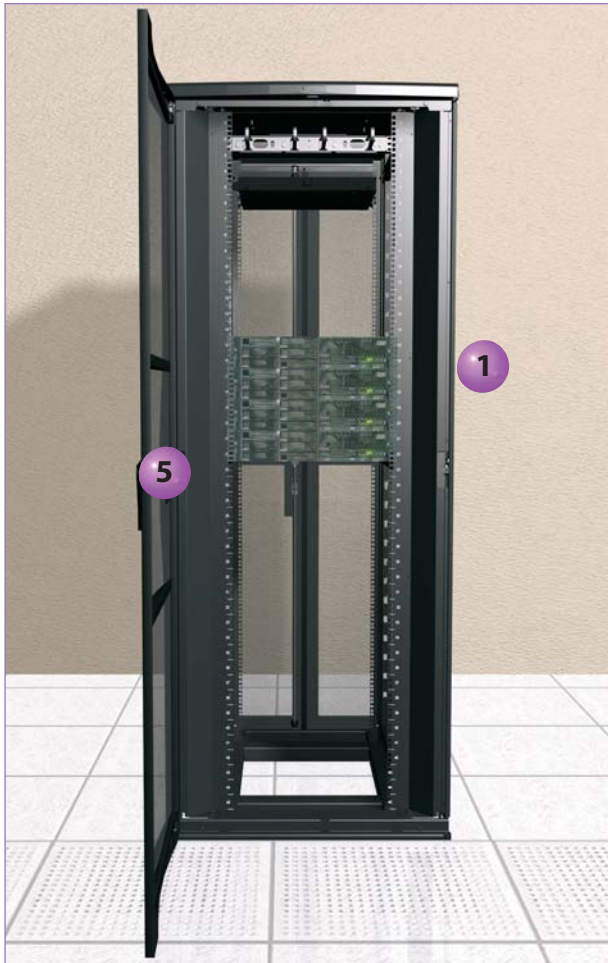

Front View

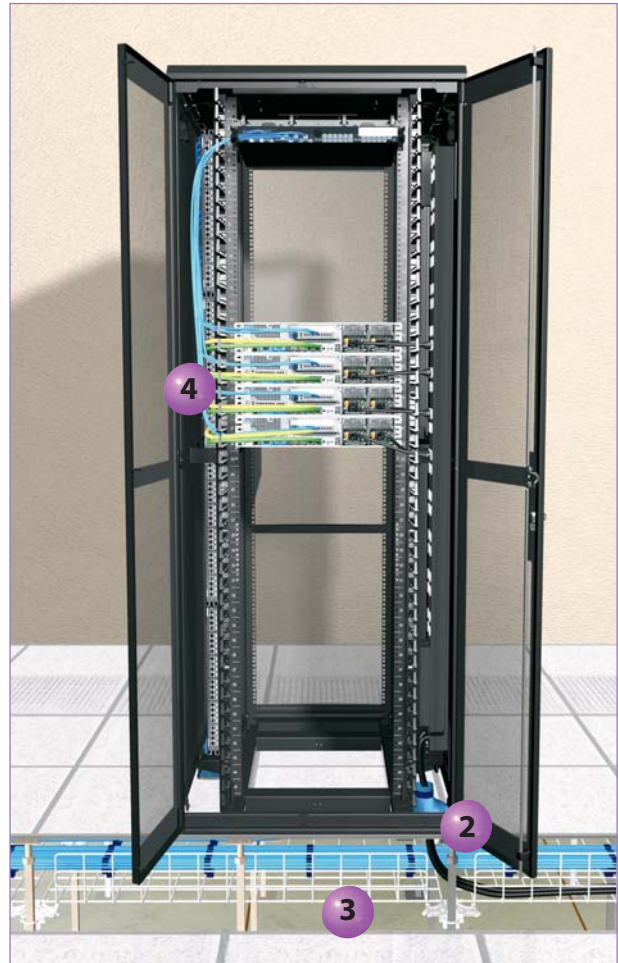

Rear View

- 1** Net-Access™ Server Cabinet
(pages L.20 and L.22) 

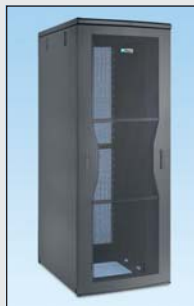

- 3** GridRunner™ Underfloor Cable
Routing System
(page J.75)

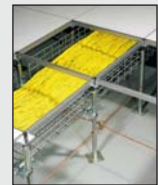

- 2** Cool Boot® Raised Floor
Air Sealing Grommet
(pages L.90 and L.91)



- 4** Vertical Patch Panel Mounting
(page L.22)



- 5** CNDSh Single Hinge Door
(page L.22) 



Net-Access™ Server Cabinets

- Inset frame posts create large and accessible vertical pathways for routing cables and mounting vertical patch panels and Power Outlet Units

- Include vertical blanking panels to block bypass air and direct cold air through servers

- Modular cable management finger sections manage cables for greater routing flexibility
- Innovative, fully integrated, electrically bonded cabinet with a single ground connection to guard against EMI and ESD, and provide a safe current path to ground
- All welded frame construction

- Adjustable rear cage nut mounting rails
- Doors include keyed swing latches
- Side panels include keyed pushbutton latches
- Equipment mounting depths up to 29" (736.6mm)
- Durable black polyester epoxy powder coat finish
- UL Listed 2500 lbs. (1134 kg) load rating
- Cabinet ships assembled, one per pallet
- For the complete grounding solution, see the StructuredGround™ Kits for Cabinets



CS1



CS2



CS3

Part Number	Part Description	Std. Pkg. Qty.
Net-Access™ 45 RU Server Cabinets		
CS1	Cabinet frame with top panel. Single hinge perforated front door. Split perforated rear doors open in the middle to minimize door swing footprint. Solid side panels. Two sets of cage nut equipment mounting rails. 45 RU cable management on rear of rear posts. One set of POU mounting brackets. Dimensions: 84.0"H x 31.5"W x 41.1"D (2134mm x 800mm x 1044mm)	1
CS1NU	Cabinet frame with top panel. Single hinge perforated front door. Split perforated rear doors open in the middle to minimize door swing footprint. Solid side panels. Two sets of cage nut equipment mounting rails installed numbered up. 45 RU cable management on rear of rear posts. One set of POU mounting brackets. Dimensions: 84.0"H x 31.5"W x 41.1"D (2134mm x 800mm x 1044mm)	1
CS1RNU	Cabinet frame with top panel. Single hinge perforated front door. Split perforated rear doors open in the middle to minimize door swing footprint. Solid side panels. Two sets of cage nut equipment mounting rails installed numbered up. 45 RU cable management on rear of rear posts. One set of POU mounting brackets. Four installed casters. Dimensions: 84.0"H x 31.5"W x 41.1"D (2134mm x 800mm x 1044mm)	1
CS2	Cabinet frame with top panel. Single hinge perforated front door. Split perforated rear doors open in the middle to minimize door swing footprint. Two sets of cage nut equipment mounting rails. 45 RU cable management on rear of rear posts. One set of POU mounting brackets. Dimensions: 84.0"H x 31.5"W x 41.1"D (2134mm x 800mm x 1044mm)	1
CS2NU	Cabinet frame with top panel. Single hinge perforated front door. Split perforated rear doors open in the middle to minimize door swing footprint. Two sets of cage nut equipment mounting rails installed numbered up. 45 RU cable management on rear of rear posts. One set of POU mounting brackets. Dimensions: 84.0"H x 31.5"W x 41.1"D (2134mm x 800mm x 1044mm)	1
CS3	Cabinet frame with top panel. Two sets of cage nut equipment mounting rails. 45 RU cable management on rear of rear posts. One set of POU mounting brackets. Dimensions: 84.0"H x 31.5"W x 40.0"D (2134mm x 800mm x 1016mm)	1

White cabinets also available upon request. Please consult Panduit Customer Service for lead-times.

Net-Access™ Server Cabinets (continued)



CS4RNU



CS5

Part Number	Part Description	Std. Pkg. Qty.
CS3NU	Cabinet frame with top panel. Two sets of cage nut equipment mounting rails installed numbered up. 45 RU cable management on rear of rear posts. One set of POU mounting brackets. Dimensions: 84.0"H x 31.5"W x 40.0"D (2134mm x 800mm x 1016mm)	1
CS4RNU	Cabinet frame with top panel. Two split perforated rear doors open in the middle to minimize door swing footprint. Solid side panels. Two sets of cage nut equipment mounting rails numbered up. 45 RU cable management on rear of rear posts. One set of POU mounting brackets. Four installed casters. One set of vertical blanking panels. Dimensions: 84.0"H x 31.5"W x 41.1"D (2134mm x 800mm x 1044mm)	1
CS5	Cabinet frame with top panel. Split perforated front doors open in the middle to minimize door swing footprint. Split perforated rear doors open in the middle to minimize door swing footprint. Two sets of cage nut equipment mounting rails. 45 RU cable management on rear of rear posts. One set of POU mounting brackets. Dimensions: 84.0"H x 31.5"W x 41.1"D (2134mm x 800mm x 1044mm)	1

Net-Access™ 42 RU Server Cabinets

CS12NU	42 available rack spaces. Cabinet frame with top panel. Single hinge perforated front door. Split perforated rear doors open in the middle to minimize door swing footprint. Solid side panels (2). Two sets of cage nut equipment mounting rails— mounted numbers up. 42 RU cable management on rear of rear posts. One set of POU mounting brackets. Dimensions: 78.8"H x 31.5"W x 41.1"D (2000mm x 800mm x 1044mm)	1
CS22NU	42 available rack spaces. Cabinet frame with top panel. Single hinge perforated front door. Split perforated rear doors open in the middle to minimize door swing footprint. Two sets of cage nut equipment mounting rails – mounted numbers up. 42 RU cable management on rear of rear posts. One set of POU mounting brackets. Dimensions: 78.8"H x 31.5"W x 41.1"D (2000mm x 800mm x 1044mm)	1

Net-Access™ 42 RU and 45 RU Extended Server Cabinets

CS28	Net-Access™ Extended Server Cabinet, front single hinge door, rear perforated split doors, no side panels, cage nut rails. Dimensions: 31.5"W x 48.9"D x 84.0"H (800mm x 1242mm x 2134mm) 45 RU	1
CS28NU	Net-Access™ Extended Server Cabinet, front single hinge door, rear perforated split doors, no side panels, cage nut rails – mounted numbers up. Dimensions: 31.5"W x 48.9"D x 84.0"H (800mm x 1242mm x 2134mm) 45 RU	1
CS28LNU	Net-Access™ Extended Server Cabinet, front single hinge door, rear perforated split doors, (1) side panel – left side, cage nut rails – mounted numbers up. Dimensions: 31.5"W x 48.9"D x 84.0"H (800mm x 1242mm x 2134mm) 45 RU	1

White cabinets also available upon request. Please consult Panduit Customer Service for lead-times.

Table continues on page L.22

 **Net-Access™ Server Cabinets (continued)**

Part Number	Part Description	Std. Pkg. Qty.
CS348	Net-Access™ Extended Server Cabinet, no doors, no side panels, cage nut rails. Dimensions: 31.5"W x 48.0"D x 84"H (800mm x 1219mm x 2134mm) 45 RU	1
CS348NU	Net-Access™ Extended Server Cabinet, vertical blanking panels, cage nut rails – mounted numbers up. Dimensions: 31.5"W x 48.0"D x 84.0"H (800mm x 1219mm x 2134mm) 45 RU	0
CS182NU	Net-Access™ Extended Server Cabinet, single hinge front door, split perforated rear doors, two sets of cage nut equipment mounting rails – mounted numbers up, 42 RU cable management on rear of rear posts, and one set of POU mounting brackets. Dimensions: 78.8"H x 31.5"W x 48.9"D (2000mm x 800mm x 1242mm)	1
CS282NU	Net-Access™ Extended Server Cabinet, single hinge perforated front door, split perforated rear doors, two sets of cage nut equipment mounting rails – mounted numbers up, 42 RU cable management on rear of rear posts, and one set of POU mounting brackets. Dimensions: 78.8"H x 31.5"W x 48.9"D (2000mm x 800mm x 1242mm)	1



CS18HNU

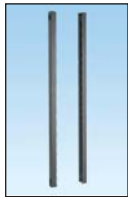

CSRCE



CNDSH



CVPDUB



CVPPB



CNCSTR

Net-Access™ 45 RU Extended Server Cabinets for Use in Vertical Exhaust Duct Applications

CS18HNU	Net-Access™ Extended Server Cabinet, front single hinge door, rear solid split door, (2) side panels, vertical blanking panels, cage nut rails – mounted numbers up. Dimensions: 31.5"W x 48.9"D x 84"H (800mm x 1242mm x 2134mm) 45 RU	1
CS28HNU	Net-Access™ Extended Server Cabinet, front single hinge door, rear solid split door, no side panels, vertical blanking panels, cage nut rails – mounted numbers up. Dimensions: 31.5"W x 48.9"D x 84"H (800mm x 1242mm x 2134mm) 45 RU	1

Net-Access™ Server Cabinet Options and Accessories

CSRCE	Extended front server cabinet cage nut equipment mounting rails, sold in pairs.	1
CNDSH	Single hinge door quickly reverses from left-hinging to right-hinging for increased data center design flexibility. Open perforated design enables optimum airflow to equipment.	1
CVPDUB	Bracket for vertical POU mounting to the side of the Net-Access™ Cabinet posts or 4 post racks (kit of two).	1
CVPPB	Bracket to vertically mount 1 RU EIA 19" copper and fiber patch panels to the side of the Net-Access™ Cabinet posts or 4 post racks.	1
CNCSTR	Network cabinet casters – set of four. Can be field installed without tipping cabinet. Adds 1.7" (43mm) to cabinet height.	1

White cabinets also available upon request. Please consult Panduit Customer Service for lead-times.

Net-Access™ Vertical Exhaust System Roadmap

Innovative Net-Access™ Vertical Exhaust System channels heat from server exhaust directly to the data center return plenum. By managing heat at the source the duct increases CRAC unit efficiency and significantly lowers operating expenses.

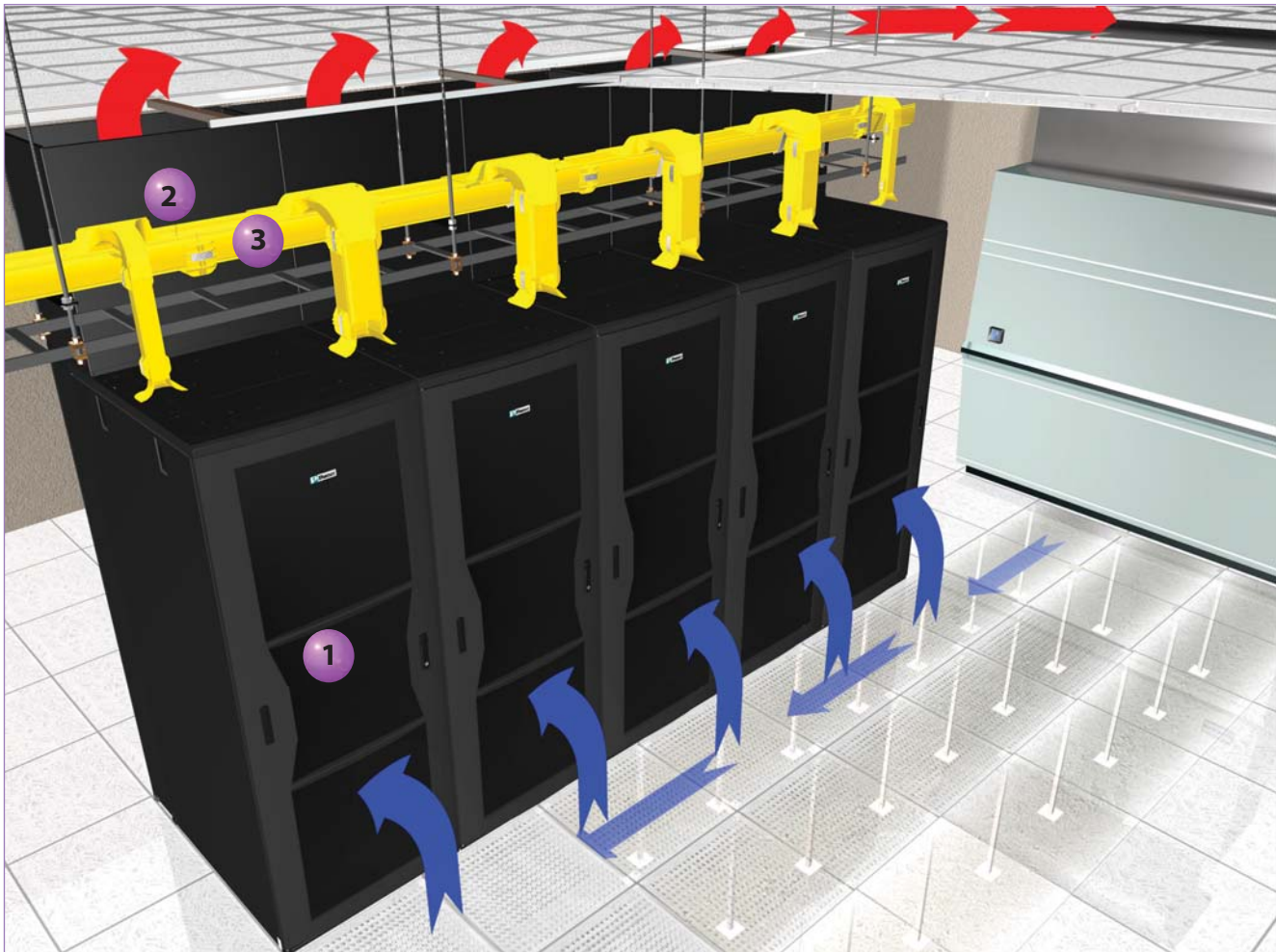

1 Net-Access™ Server Cabinet
(pages L.20 and L.22) 

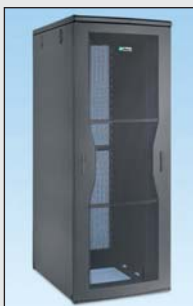

3 FiberRunner® Cable Routing System
(page J.1)



2 CVED32VE Variable Duct Extension
(page L.18)



NEW! Net-Contain™ Cold Aisle Containment System

The Net-Contain™ System creates a structure including end-of-row dual sliding doors and ceiling panels that enclose the cold aisle between rows of Panduit 42 RU or 45 RU Net-Access™ and Net-SERV® Cabinets to prevent mixing of cold and hot air, optimizing cool air delivery.

- Reduces cooling energy costs up to 42%
- Up to 20kW+ cabinet heat load
- Compatible with numerous Panduit product lines including CabRunner®, FiberRunner®, and Wyr-Grid® Cable Routing Systems



Integral Low Profile Ceiling Structure

- Available in 4 ft. (1200mm) or 6 ft. (1800mm) lengths of 600mm, 700mm, 800mm widths
- Access holes allow fire suppression to enter the containment
- Available in black or white frame structure

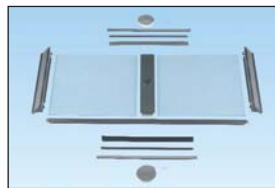

CXCAC08F06IRBL

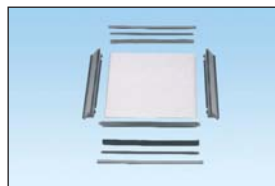

NSCAC06F04IRBL

Part Number	Part Description	Std. Pkg. Qty.
CXCAC08F04IRBL	Net-Contain™ Cold Aisle Containment Integral Roof for 800mm wide Net-Access™ Switch and Server Cabinets with 4' (1200mm) aisle width. Includes 4' low profile wall/ceiling kits.	1
CXCAC08F06IRBL	Net-Contain™ Cold Aisle Containment Integral Roof for 800mm wide Net-Access™ Switch and Server Cabinets with 6' (1800mm) aisle width. Includes 6' low profile wall/ceiling kits.	1
NSCAC07F04IRBL	Net-Contain™ Cold Aisle Containment Integral Roof for 700mm wide Net-SERV® Cabinet with 4' (1200mm) aisle width. Includes 4' low profile wall/ceiling kits.	1
NSCAC07F06IRBL	Net-Contain™ Cold Aisle Containment Integral Roof for 700mm wide Net-SERV® Cabinet with 6' (1800mm) aisle width. Includes 6' low profile wall/ceiling kits.	1
NSCAC06F04IRBL	Net-Contain™ Cold Aisle Containment Integral Roof for 600mm wide Net-SERV® Cabinet with 4' (1200mm) aisle width. Includes 4' low profile wall/ceiling kits.	1
NSCAC06F06IRBL	Net-Contain™ Cold Aisle Containment Integral Roof for 600mm wide Net-SERV® Cabinet with 6' (1800mm) aisle width. Includes 6' low profile wall/ceiling kits.	1

End of Row Dual Sliding Door Solution

- Can be installed in either a 4 ft. (1200mm) or 6 ft. (1800mm) aisle
- Mount to either Net-Access™ or Net-SERV® Cabinets
- Easy access to cabinet aisle area
- Damper keeps doors from slamming closed and ensures that the doors stay closed
- Uses gravity to automatically close doors
- Available in black or white frame structure



NACACT5F08DSBL

Part Number	Part Description	Std. Pkg. Qty.
NACACT5F08DSBL	Net-Contain™ Cold Aisle Containment Dual Sliding Door for Net-SERV® and Net Access™ Server and Switch Cabinets. Accommodates 4' (1200mm) up to 6' (1800mm) aisle widths, 42 RU up to 45 RU.	1

Thermal Ducting Solutions

Inlet Ducts

- Cisco compatible
- Passive duct solutions do not require additional energy consumption
- Designed using CFD (Computational Fluid Dynamics) validating thermal performance
- Provides a consistent cold air path directly to the switch
- Allows access to power supplies and fan blades minimizing network downtime
- Black powder coat finish



CDE1



CDE2



CNLTD21B2



CNLTD52A2



CNLTD142A3

CNLTD72A3



Part Number	Part Description	Std. Pkg. Qty.
CDE1	One rack unit air inlet duct that resides below the switch provides cold aisle airflow to Cisco^ 4948, 4928, and 4924. Optimized for use in server cabinet applications.	1
CDE2	Two rack unit air inlet duct that resides in-line and below switch provides cold aisle airflow to Cisco^ Nexus N2K-C2148T-1GE, N2K-C2248TP-1GE, and N2K-C2232PP-10GE fabric extenders and Cisco^ WS-C4948E-F, WS-C4948E-F-S, and WS-C4948E-F-E. Optimized for use in server cabinet applications.	1
CNLTD21B2	Two rack unit air inlet duct that resides below switch. Designed for Cisco^ 4900M switch. Duct allows switch ports to face either hot or cold aisle depending on server or switch cabinet application.	1
CNLTD52A2	Net-Access™ Cabinet Air Inlet Duct for high heat density configurations. Duct solution includes two rack unit inlet ducts above and below the switch. Designed for Cisco^ 6504E switch.	1
CNLTD142A3	Cisco^ Nexus 7009 duct delivers cold air to the switch side inlet. This duct consists of 2 inlet ducts and 1 side duct.	1
CNLTD72A3	Net-Access™ or Net-SERV® Cabinet Air Inlet Duct for high heat density configurations. Duct solution includes three rack unit inlet ducts above and below the switch. Designed for Cisco^ 9506 switch.	1

^Cisco is a registered trademark of Cisco Technology, Inc.

Exhaust Ducts

- Cisco compatible
- Passive duct solutions do not require additional energy consumption
- Designed using CFD (Computational Fluid Dynamics) validating thermal performance
- Provides a consistent hot air exhaust path minimizing recirculation within the cabinet
- Allows access to power supplies and fan blades minimizing network downtime
- Black powder coat finish



CNAE1

Part Number	Part Description	Std. Pkg. Qty.
CNAE1	Net-Access™ Cabinet Exhaust Duct for high heat density configurations. Designed for Cisco^ 6509 switch.	1
CNAE2	Net-Access™ Cabinet Exhaust Duct for high heat density configurations. Designed for Cisco^ 9513 storage area network switch.	1
CNAE3	Net-Access™ Cabinet Exhaust Duct for high heat density configurations. Designed for Cisco^ 6513 switch.	1

^Cisco is a registered trademark of Cisco Technology, Inc.



CabRunner[®] Overhead Cable Routing System

- Wide molded design provides a high capacity pathway that is self-supporting and does not need secondary mounting infrastructure
- Designed specifically for use with Net-Access[™] Switch and Server Cabinets
- Integral spillouts align with cable inlets on cabinet and provide 3" (75mm) bend radius control
- Clean, simple design complements Net-Access[™] Cabinets providing greater data center aesthetics

**CRB6BL****CRB6VEDBL****CRBRDGBL****CRB6ECBL****CRTB****CRVEDTB**

Part Number	Part Description	Std. Pkg. Qty.	Std. Ctn. Qty.
Base Unit			
CRB6BL	CabRunner [®] Overhead Cable Routing System Base Unit with 6" (150mm) high wall. Supplied with shroud and fasteners required for assembly to Net-Access [™] Cabinets.	1	—
CRB6VEDBL	CabRunner [®] Overhead Cable Routing System Base Unit with 6" (150mm) high wall. Supplied with a shroud and fasteners required for assembly to Net-Access [™] Cabinets with a vertical exhaust duct.	1	—
Bridge Insert			
CRBRDGBL	CabRunner [®] Overhead Cable Routing System Bridge Insert. Snaps into CRB6BL to cover unused cable spillouts and provide bend radius control for adjacent cabinet. Two inserts required for each opening in CabRunner [®] Base Unit.	1	5
End Cap for Net-Access[™] Cabinet			
CRB6ECBL	CabRunner [®] Overhead Cable Routing System End Cap. Snaps onto the CRB6BL CabRunner [®] Base, to close off the open ends of the Panduit [®] Net-Access [™] Cabinet lineup. (Sold in pairs to accommodate each end of a cabinet line up). No tools required.	2	—
Trapeze Bracket			
CRTB	CabRunner [®] Overhead Cable Routing System Trapeze Bracket. Used to provide a mounting structure for integrating FiberRunner [®] Cable Routing System to the base unit.	1	—
CRVEDTB	CabRunner [®] Overhead Cable Routing System Trapeze Bracket. Used to provide a mounting structure for integrating FiberRunner [®] Cable Routing System to the base unit on Net-Access [™] Cabinets with a vertical exhaust duct.	1	—

Net-SERV® Cabinets

- 1200mm (48") depth and 1070mm (42.1") depth
- Two sets, cage nut, infinitely adjustable equipment mounting rails, 50 #12-24 cage nuts and screws included
- Printed rack space identification on front and back of rails, default is numbers up, may be field adjusted to numbers down
- Equipment mounting depth up to 42" (1067mm)
- Doors include keyed swing handles
- Side panels include keyed locks
- POU mounting brackets included to mount two POU's
- Vertical blanking panels installed
- Easily adjustable leveling legs installed
- Ganging brackets included
- Anti-tip brackets included
- Available in four configuration options: Basic, Standard Density, High Density, and Vertical Patching
- Durable black polyester epoxy powder coat finish
- All welded frame construction
- 2500 lbs. (1134 kg) load rating
- Removable top cap included
- Cabinet ships assembled, one per pallet
- Optional casters available
- Optional vertical exhaust duct for maximum energy efficiency

Part Number Example:

S	7	5	2	C	1	2	9	F	V
Series	Width	Height	Depth	Rails	Front Doors	Back Doors	Side Panel	Cable Management	Top Panel
S = Server	6 = 600mm (23.6") 7 = 700mm (27.6")	2 = 42RU 5 = 45RU	2 = 1200mm (47.2") 0 = 1070mm (42.1")	C = Cage Nuts, Numbers Up	1 = Perf. Full Single Hinge	2 = Perforated Split 3 = Solid Full Single Hinge	1 = One Side Panel 2 = Two Side Panels 9 = No Side Panels	F = Standard Density – Left and Right Fingers H = High Density – Four Cable Management Panels P = Vertical Patch B = Basic – No Cable Mgmt.	V = Vertical Exhaust Duct (VED included) VR = Vertical Exhaust Duct (VED not included)

Basic Configuration

- Cabinet provided without cable management
- Includes brackets for mounting two vertical power outlet units



Part Number	Part Description	Width		Height		No. of Rack Spaces	Std. Pkg. Qty.
		In.	mm	In.	mm		
Net-SERV® 1200mm Deep Cabinets							
S722C122B	Cabinet with full perforated front door. Split perforated rear door. Solid side panels.	28	700	78	1984	42	1
S752C122B		28	700	83	2118	45	1
S622C122B		24	600	78	1984	42	1
S652C122B		24	600	83	2118	45	1
Net-SERV® 1070mm Deep Cabinets							
S722C129B	Cabinet with full perforated front door. Split perforated rear door. No side panels.	28	700	78	1984	42	1
S752C129B		28	700	83	2118	45	1
S622C129B		24	600	78	1984	42	1
S652C129B		24	600	83	2118	45	1
Net-SERV® 1070mm Deep Cabinets							
S620C122B	Cabinet with full perforated front door. Split perforated rear door. Solid side panels.	24	600	78	1984	42	1
S620C129B	Cabinet with full perforated front door. Split perforated rear door. No side panels.	24	600	78	1984	42	1

White cabinets also available upon request. Please consult Panduit Customer Service for lead-times.

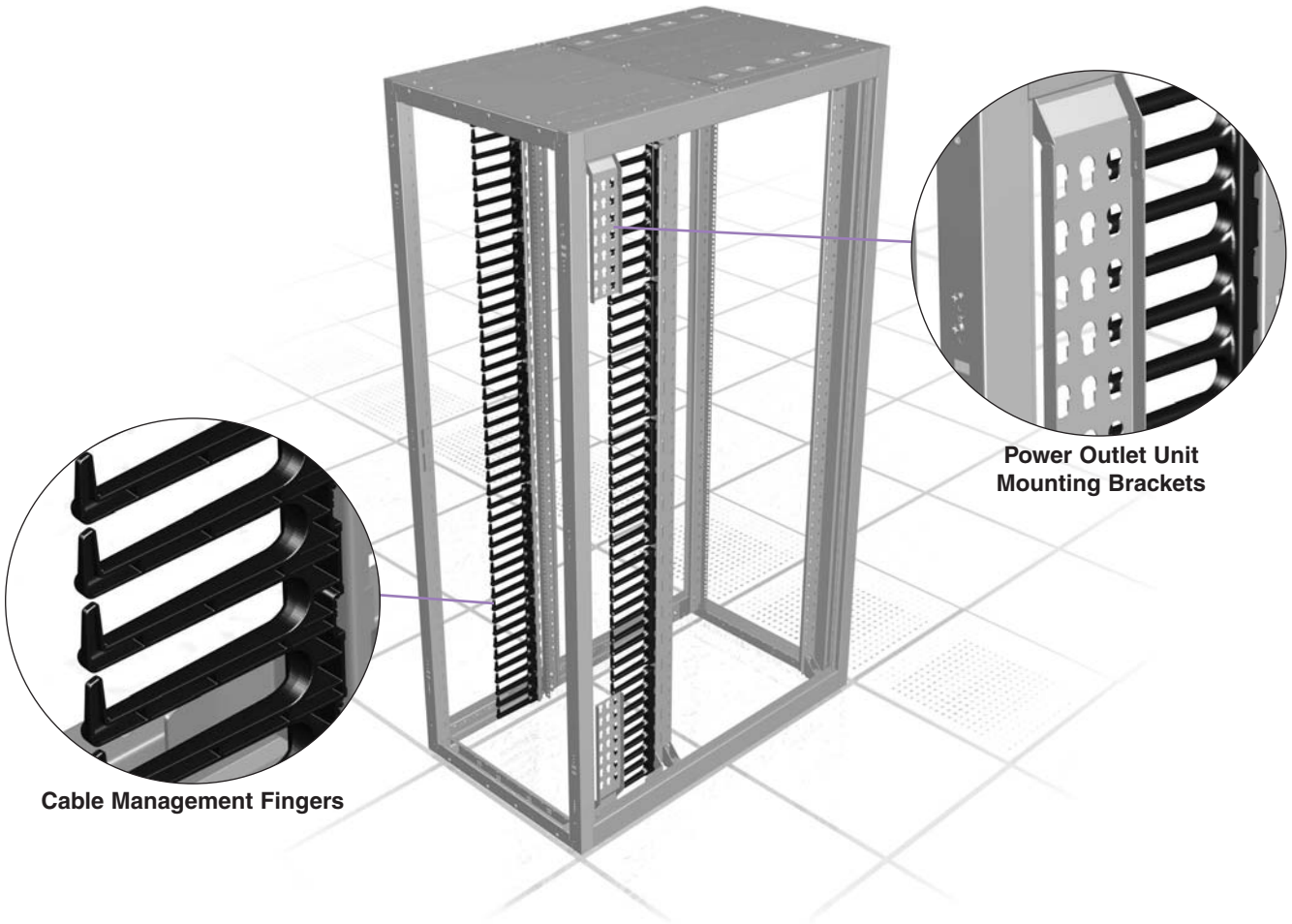

Cable Management Fingers

Power Outlet Unit Mounting Brackets

Standard Density Cable Management Configuration

- Cabinet supplied with two sets of cable management fingers



Part Number	Part Description	Width		Height		No. of Rack Spaces	Std. Pkg. Qty.
		In.	mm	In.	mm		
S722C122F	Cabinet with full perforated front door. Split perforated rear door. Solid side panels.	28	700	78	1984	42	1
S752C122F		28	700	83	2118	45	1
S622C122F		24	600	78	1984	42	1
S652C122F		24	600	83	2118	45	1
S722C129F	Cabinet with full perforated front door. Split perforated rear door. No side panels.	28	700	78	1984	42	1
S752C129F		28	700	83	2118	45	1
S622C129F		24	600	78	1984	42	1
S652C129F		24	600	83	2118	45	1

White cabinets also available upon request. Please consult Panduit Customer Service for lead-times.

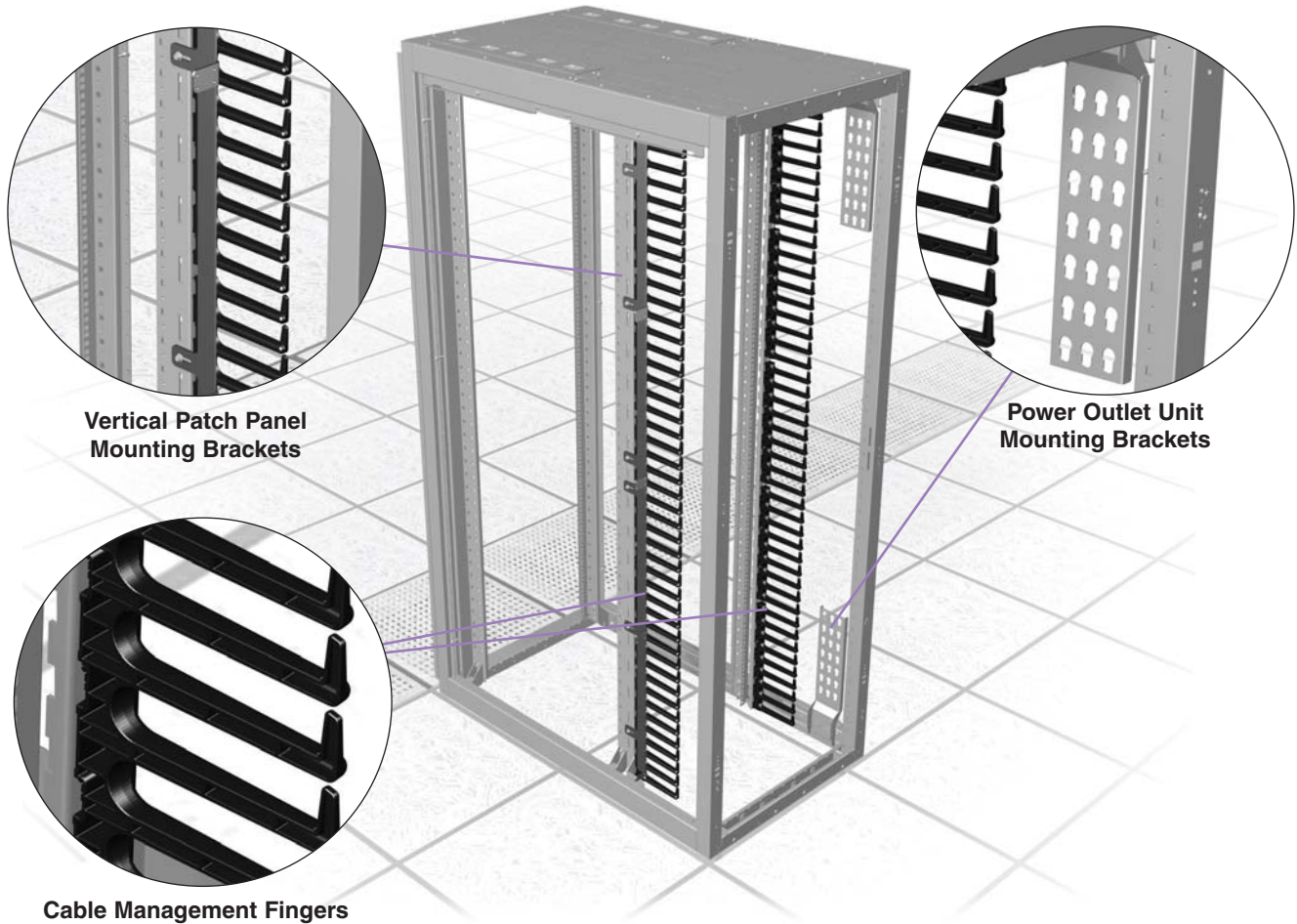

Vertical Patch Panel Mounting Brackets

Power Outlet Unit Mounting Brackets

Cable Management Fingers

Vertical Patch Cable Management Configuration

- Cabinet supplied with cable management fingers and vertical 19" EIA brackets



Part Number	Part Description	Width		Height		No. of Rack Spaces	Std. Pkg. Qty.
		In.	mm	In.	mm		
S722C122P	Cabinet with full perforated front door. Split perforated rear door.	28	700	78	1984	42	1
S752C122P	Solid side panels.	28	700	83	2118	45	1
S722C129P	Cabinet with full perforated front door. Split perforated rear door.	28	700	78	1984	42	1
S752C129P	No side panels.	28	700	83	2118	45	1

White cabinets also available upon request. Please consult Panduit Customer Service for lead-times.

A. System Overview

B. Copper Systems

C. Fiber Optic Systems

D. Power over Ethernet

E. Zone Cabling

F. Wireless

G. Outlets

H. Media Distribution

I. Physical Infrastructure Management

J. Overhead & Underfloor Routing

K. Surface Raceway

L. Cabinets, Racks & Cable Management

M. Grounding & Bonding

N. Industrial

O. Labeling & Identification

P. Cable Management Accessories

Q. Index

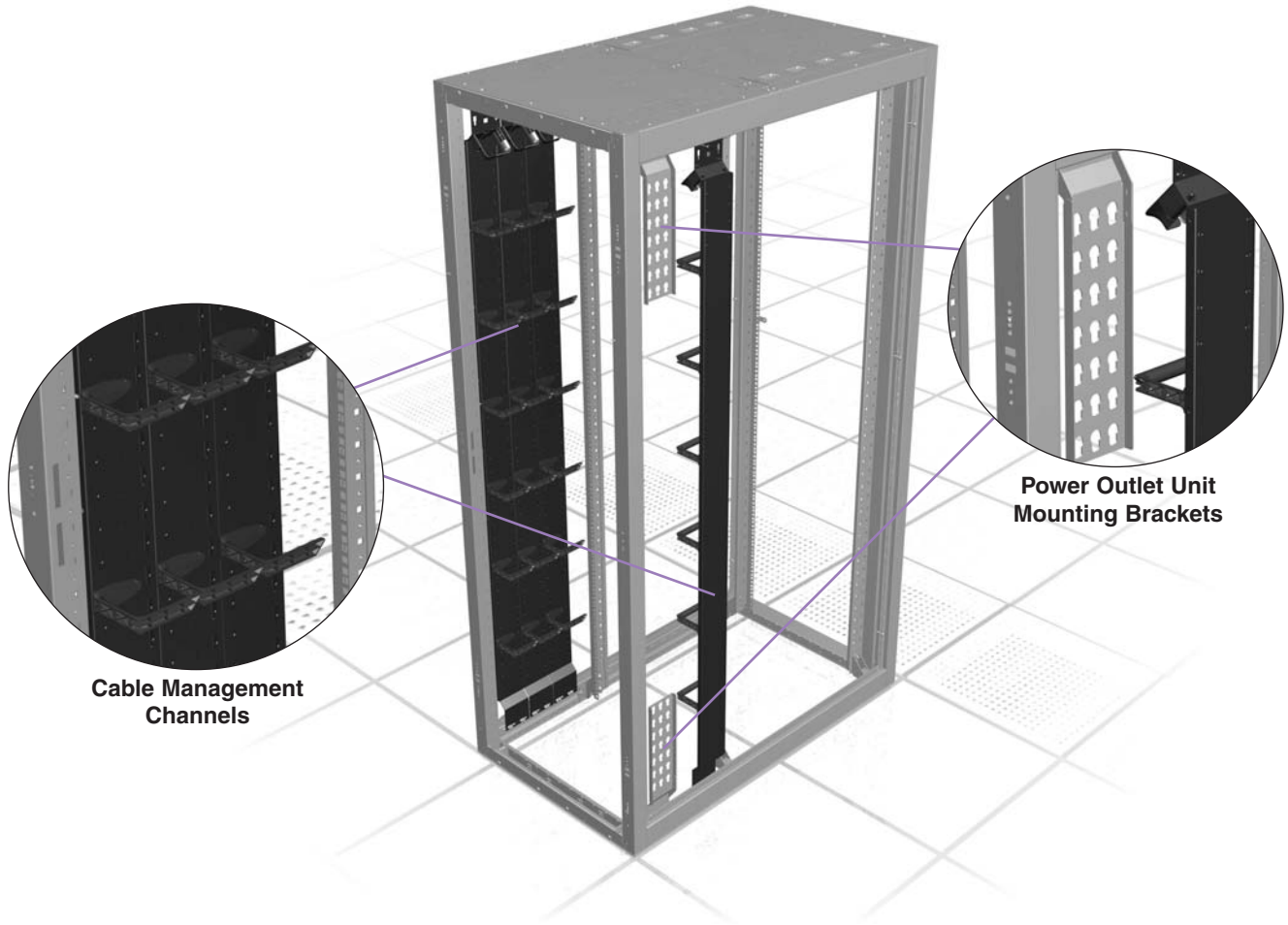

High Density Cable Management Configuration

- Cabinet supplied with four cable management channels and L-rings



Part Number	Part Description	Width		Height		No. of Rack Spaces	Std. Pkg. Qty.
		In.	mm	In.	mm		
S722C122H	Cabinet with full perforated front door. Split perforated rear door. Solid side panels.	28	700	78	1984	42	1
S752C122H	Cabinet with full perforated front door. Split perforated rear door. Solid side panels.	28	700	83	2118	45	1
S622C122H	Cabinet with full perforated front door. Split perforated rear door. Solid side panels.	24	600	78	1984	42	1
S652C122H	Cabinet with full perforated front door. Split perforated rear door. Solid side panels.	24	600	83	2118	45	1
S722C129H	Cabinet with full perforated front door. Split perforated rear door. No side panels.	28	700	78	1984	42	1
S752C129H	Cabinet with full perforated front door. Split perforated rear door. No side panels.	28	700	83	2118	45	1
S622C129H	Cabinet with full perforated front door. Split perforated rear door. No side panels.	24	600	78	1984	42	1
S652C129H	Cabinet with full perforated front door. Split perforated rear door. No side panels.	24	600	83	2118	45	1

White cabinets also available upon request. Please consult Panduit Customer Service for lead-times.

Configuration for Vertical Exhaust Duct and High Density Management

- Cabinet supplied with four cable management channels and L-Rings
- Directly vents network equipment exhaust into return plenum of data center
- Includes vertical blanking panels where appropriate and front and back floor seals



S722C131HV S722C131HVR
S752C131HV S752C131HVR
S622C131HV S622C131HVR
S652C131HV S652C131HVR

Part Number	Part Description	No. of Rack Spaces	Std. Pkg. Qty.
S722C131HV	Cabinet with full perforated front door. Solid rear door. Single side panel. Vertical exhaust duct extends cabinet 42" (1067mm) to 70" (1778mm).	42	1
S752C131HV	Cabinet with full perforated front door. Solid rear door. Single side panel. Vertical exhaust duct extends cabinet 42" (1067mm) to 70" (1778mm).	45	1
S622C131HV	Cabinet with full perforated front door. Solid rear door. Single side panel. Vertical exhaust duct extends cabinet 42" (1067mm) to 70" (1778mm).	42	1
S652C131HV	Cabinet with full perforated front door. Solid rear door. Single side panel. Vertical exhaust duct extends cabinet 42" (1067mm) to 70" (1778mm).	45	1
S722C131HVR	Cabinet with perforated single hinge front door. Solid single hinge back door. One side panel. Cage nut equipment rails mounted numbers up. Vertical exhaust duct not included.	42	1
S752C131HVR	Cabinet with perforated single hinge front door. Solid single hinge back door. One side panel. Cage nut equipment rails mounted numbers up. Vertical exhaust duct not included.	45	1
S622C131HVR	Cabinet with perforated single hinge front door. Solid single hinge back door. One side panel. Cage nut equipment rails mounted numbers up. Vertical exhaust duct not included.	42	1
S652C131HVR	Cabinet with perforated single hinge front door. Solid single hinge back door. One side panel. Cage nut equipment rails mounted numbers up. Vertical exhaust duct not included.	45	1

White cabinets also available upon request. Please consult Panduit Customer Service for lead-times.

Vertical Exhaust Ducting



Part Number	Part Description	Std. Pkg. Qty.
Vertical Exhaust Ducting for Net-SERV® Cabinets		
NSVED0611632BL	Vertical Exhaust Duct (VED) for 600mm Wide Net-SERV® Cabinet, height adjustable from 16.0" (406mm) up to 32.0" (813mm).	1
NSVED0711632BL	Vertical Exhaust Duct (VED) for 700mm Wide Net-SERV® Cabinet, height adjustable from 16.0" (406mm) up to 32.0" (813mm).	1
NSVED0613266BL	Vertical Exhaust Duct (VED) for 600mm Wide Net-SERV® Cabinet, height adjustable from 32.0" (813mm) up to 66.0" (1,676mm).	1
NSVED0713266BL	Vertical Exhaust Duct (VED) for 700mm Wide Net-SERV® Cabinet, height adjustable from 32.0" (813mm) up to 66.0" (1,676mm).	1
NSMOR07A4548BL	Net-SERV® Middle of Row Sealing Accessory, 45 RU x 48" Depth for 700mm Wide cabinet x 42 RU (cabinet to cabinet - w/o cabinet side panel).	1

Net-SERV® Doors and Floor Sealing Assemblies



Part Number	Part Description	Std. Pkg. Qty.
NSRDF06R0042BL	Net-SERV® Solid Rear Door and Floor Sealing Assembly for 600mm wide cabinet, 42 RU.	1
NSRDF07R0042BL	Net-SERV® Solid Rear Door and Floor Sealing Assembly for 700mm wide cabinet, 42 RU.	1
NSRDF06R0045BL	Net-SERV® Solid Rear Door and Floor Sealing Assembly for 600mm wide cabinet, 45 RU.	1
NSRDF07R0045BL	Net-SERV® Solid Rear Door and Floor Sealing Assembly for 700mm wide cabinet, 45 RU.	1

Net-SERV[®] Colocation Cabinet

Part Number	Part Description	No. of Rack Spaces	Std. Pkg. Qty.
Net-SERV[®] 700mm Wide, Split Colocation Cabinet			
S752S2C122B	Net-SERV [®] 700mm wide, 45 RU, Split Colo-Cabinet, with single perforated front door, split perforated rear doors, two side panels, and no cable management.	45	1

Net-SERV[®] Accessories

Part Number	Part Description	Std. Pkg. Qty.
-------------	------------------	----------------

**S22PS
S52PS****Side Panels**

S22PS	42 RU removable solid side panel covers and protects cable and equipment. Single lock allows for quick release and removal of side panels for easier and faster moves, adds, and changes.	1
S52PS	45 RU removable solid side panel covers and protects cable and equipment. Single lock allows for quick release and removal of side panels for easier and faster moves, adds, and changes.	1

**S62RC
S72RC
S65RC
S75RC****Equipment Mounting Rails**

S62RC	42 RU x 600mm (24") wide cage nut equipment mounting rails, sold in pairs.	1
S72RC	42 RU x 700mm (28") wide cage nut equipment mounting rails, sold in pairs.	1
S65RC	45 RU x 600mm (24") wide cage nut equipment mounting rails, sold in pairs.	1
S75RC	45 RU x 700mm (28") wide cage nut equipment mounting rails, sold in pairs.	1

Casters

SCSTR	Includes set of four casters.	1
--------------	-------------------------------	---

**SCSTR****Power Outlet Unit Mounting Brackets**

SVPDUB	Brackets for tool-less mounting of two 2" (51mm) widepower outlet units.	1
---------------	--	---

**SVPPB****Vertical Patch Panel Mounting Bracket**

SVPPB	Net-SERV [®] Bracket to vertically mount 1 RU EIA 19" products including copper and fiber patch panels. Compatible with 700mm Net-SERV [®] Cabinets with finger bracket cable managers only.	1
--------------	--	---

**SRFS-KIT****S62BRFK
S65BRFK
S72BRFK
S75BRFK****Floor Seal Skirt for Net-SERV[®] Cabinets with Casters**

SRFS-KIT	Net-SERV [®] 48"/1200mm deep, End of Row Sealing Kit for Use with Casters to complete one side.	1
-----------------	--	---

Finger Brackets for Net-SERV[®] Cabinets

S62BRFK	Net-SERV [®] 24"/600 wide x 42 RU, cable management finger sections and bracket kit to complete two sides.	1
S65BRFK	Net-SERV [®] 24"/600 wide x 45 RU, cable management finger sections and bracket kit to complete two sides.	1
S72BRFK	Net-SERV [®] 28"/700 wide x 42 RU, cable management finger sections and bracket kit to complete two sides.	1
S75BRFK	Net-SERV [®] 28"/700 wide x 45 RU, cable management finger sections and bracket kit to complete two sides.	1

Net-SERV® Accessories (continued)



S62BRCK
S65BRCK
S72BRCK
S75BRCK



S65DS
S62DS
S75DS
S72DS

S65DSH
S62DSH
S75DSH
S72DSH

Part Number	Part Description	Std. Pkg. Qty.
High Density Cable Management Brackets for Net-SERV™ Cabinets		
S62BRCK	Net-SERV® 24"/600mm wide x 42 RU, vertical cable management L-Rings and bracket kit to complete one panel.	1
S65BRCK	Net-SERV® 24"/600mm wide x 45 RU, vertical cable management L-Rings and bracket kit to complete one panel.	1
S72BRCK	Net-SERV® 28"/700mm wide x 42 RU, vertical cable management L-Rings and bracket kit to complete one panel.	1
S75BRCK	Net-SERV® 28"/700mm wide x 45 RU, vertical cable management L-Rings and bracket kit to complete one panel.	1
Perforated Net-SERV® Doors		
S65DS	Rear perforated split door for Net-SERV® 600mm wide, 45 RU Cabinet.	1
S65DSH	Single hinge perforated door for Net-SERV® 600mm wide, 45 RU Cabinet.	1
S62DS	Rear perforated split door for Net-SERV® 600mm wide, 42 RU Cabinet.	1
S62DSH	Single hinge perforated door for Net-SERV® 600mm wide, 42 RU Cabinet.	1
S75DS	Rear perforated split door for Net-SERV® 700mm wide, 45 RU Cabinet.	1
S75DSH	Single hinge perforated door for Net-SERV® 700mm wide, 45 RU Cabinet.	1
S72DS	Rear perforated split door for Net-SERV® 700mm wide, 42 RU Cabinet.	1
S72DSH	Single hinge perforated door for Net-SERV® 700mm wide, 42 RU Cabinet.	1

A.
System
Overview

B.
Copper
Systems

C.
Fiber
Optic
Systems

D.
Power
over
Ethernet

E.
Zone
Cabling

F.
Wireless

G.
Outlets

H.
Media
Distribution

I.
Physical
Infrastructure
Management

J.
Overhead &
Underfloor
Routing

K.
Surface
Raceway

L.
Cabinets,
Racks &
Cable
Management

M.
Grounding &
Bonding

N.
Industrial

O.
Labeling &
Identification

P.
Cable
Management
Accessories

Q.
Index

Top of Cabinet Air Sealing Accessories

Designed for the Net-Access™ and Net-SERV® Cabinets, innovative air sealing accessories prevent cooling air from escaping through cable inlets improving thermal efficiency of the cabinets. Air sealing accessories snap into the cabinet top knock-outs for fast configuration.

600 mm (24") Net-SERV® Cabinet shown with optional vertical exhaust duct.

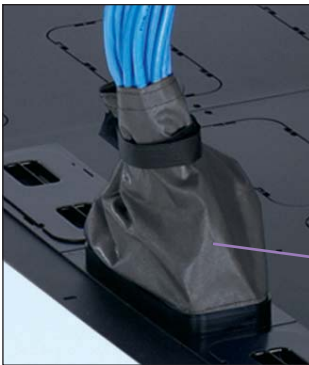

Cool Boot® Cabinet Top Air Sealing Fitting is used to seal copper data cables entering the cabinet.

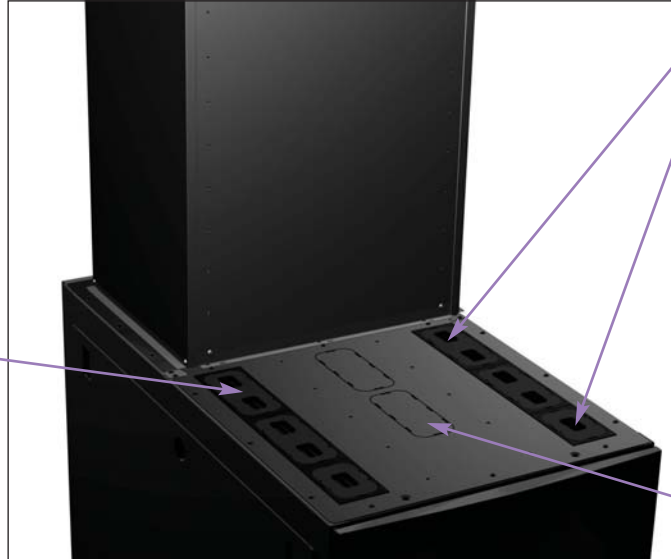

Net-SERV® Cabinets are provided with four pre-installed 3"x 8" and two 3"x 5" cabinet top covers and cable protection bezels.



Cabinet Top Air Sealing Fiber Optic Fitting is used to provide a transition and seal for fiber optic cables entering the cabinet via slit corrugated tubing.



Cabinet Top Cover and Cable Protection Bezel are used when additional knock-outs are removed from the cabinet.



Part Number	Part Description	Std. Pkg. Qty.
Cool Boot® Cabinet Top Air Sealing Fitting		
CTG3X8	Used to seal off 3" x 8" cabinet top openings when cables are routed through the top of a cabinet. Airtight fabric and Ultra-Cinch™ Tie closes top of fabric, minimizing hot air bypass around cables to improve cooling of network equipment and reduce energy costs. For use with both Net-SERV® and Net-Access™ Cabinets. Requires cabinet top cable protection bezel to be installed.	1
Cabinet Top Air Sealing Fiber Optic Fitting		
CTIDT15	Used to transition 1.5" (38mm) diameter slit corrugated tubing directly into a 3" x 8" or 3" x 5" cabinet top opening. Split design allows easy access to add or remove cables. Fitting minimizes hot air bypass around tubing to improve cooling of network equipment and reduce energy costs. For use with both Net-SERV® and Net-Access™ Cabinets. Requires cabinet top cable protection bezel to be installed.	1
Cabinet Top Cover and Cable Protection Bezel		
CTCC3X8	Used to seal off 3" x 8" cabinet top openings after knock-outs are removed. Can also be used to add the CTG3X8 or CTIDT15 to openings where knock-out has been removed. For use with both Net-SERV® and Net-Access™ Cabinets.	1
Slit Corrugated Loom Tubing		
CLT150F-X3*	Provides a vertical pathway as cables transfer from the FiberRunner® Fitting to the equipment below. Inside diameter is 1.48" (37.6mm) and outside diameter 1.73" (43.9mm). Sold in 10' rolls.	1

*For other colors replace suffix X3 (Orange) with X4 (Yellow) or X20 (Black).

Power and Environmental Management

Panduit Power Outlet Units (POUs) safely and efficiently manage and distribute power to allow multiple pieces of equipment to share a single power connector to enhance scalability of network build outs. Mounting flexibility allows quick and easy installation, and when used with Panduit® Net-Access™ and Net-SERV® Cabinets, the user receives a complete networking solution that will satisfy data center requirements today and into the future.

Basic and Metered Power Outlet Units

- Mounting brackets and screws included
- Integrated local power monitor display
- Power on indicator – green LED
- Scrolling power meter
- Surge protection

Power Strip Options Single Phase 15, 20, 30, and 60 AMPS



CMRPSH15

Part Number	Part Description	Std. Pkg. Qty.
Horizontal 15 AMP, Single Phase 120V		
CMRPSH15	Horizontal power strip 15 A, 120V, ten NEMA 5-15R receptacles, one 15 A thermal breaker, 10' power cord with NEMA 5-15P plug. UL and c-UL Listed. Dimensions: 1.7"H x 19.0"W x 3.8"D (44mm x 483mm x 95mm)	1
Horizontal 15 Amp with Surge Protection 120V		
CMRPSH15S	Horizontal power strip with a 15 A, 120V, 10 NEMA 5-15R receptacles, one 15 A thermal breaker, surge suppression indicator, and 10' power cord with NEMA 5-15P plug. UL and c-UL Listed. Dimensions: 1.7"H x 17.0"W x 3.8"D (44mm x 431mm x 95mm)	1
Vertical 15 AMP with Surge Protection 120V		
CMRPSV15SIL	Vertical power strip with a 15 A, 120V, 20 NEMA 5-15R in-line receptacles, one 15 A thermal breaker, red LED surge suppression indicator, and 10' power cord with NEMA 5-15P plug. UL and c-UL Listed. Dimensions: 66.3"H x 1.9"W x 1.6"D (1683mm x 47mm x 33mm)	1
CMRPSV15SILM	Vertical power strip with a 15 A, 120V, 20 NEMA 5-15R in-line receptacles, one 15 A thermal breaker, red LED surge suppression indicator, red LED current monitor, and 10' power cord with NEMA 5-15P plug. UL and c-UL Listed. Dimensions: 66.3"H x 1.6"W x 1.3"D (1683mm x 42mm x 34mm)	1
Horizontal 20 AMP, Single Phase 120V		
CMRPSH20*	Horizontal power strip 20 A, 120V, ten NEMA 5-20R receptacles, one 20 A thermal breaker, 10' power cord with NEMA 5-20P plug. UL and c-UL Listed. Dimensions: 1.7"H x 19.0"W x 3.8"D (44mm x 483mm x 95mm)	1
Horizontal 20 AMP with Surge Digital Monitor 120V		
CMRPSH20S	Horizontal power strip with a 20 A, 120V, 10 NEMA 5-20R receptacles, one 20 A thermal breaker, surge suppression indicator, and 10' power cord with NEMA 5-20P plug. UL and c-UL Listed. Dimensions: 1.7"H x 17.0"W x 3.8"D (44mm x 431mm x 95mm)	1
CMRPSH20STL	Horizontal power strip with a 20 A, 120V, 10 NEMA 5-20R receptacles, one 20 A thermal breaker, red LED surge suppression indicator, and 10' power cord with NEMA L5-20P twist lock plug. UL and c-UL Listed. Dimensions: 1.7"H x 17.0"W x 3.8"D (44mm x 431mm x 95mm)	1
Horizontal 20 AMP with Surge and Digital Monitor 120V		
CMRPSH20SMTL	Horizontal power strip with a 20 A, 120V, 10 NEMA 5-20R receptacles, one 20 A thermal breaker, red LED surge suppression indicator, red LED current monitor, and 10' power cord with NEMA L5-20P twist lock plug. UL and c-UL Listed. Dimensions: 1.7"H x 17.0"W x 3.8"D (44mm x 431mm x 95mm)	1

*For local digital monitor add "CM".

Refer to www.panduit.com for detailed information on the complete line of power outlet units.

Table continues on page L.36

Basic and Metered Power Outlet Units (continued)

Part Number	Part Description	Std. Pkg. Qty.
Horizontal 20 AMP with and without Digital Monitor 208V		
HB0B1E1BN12H1	Horizontal power strip with a 20 A, 208V, 12 NEMA 6-20R receptacles, one 20 A double pole magnetic breaker/on-off switch with integral switch guard, and 10' power cord with NEMA 6-20P plug. UL and c-UL Listed. Dimensions: 1.7"H x 17.0"W x 6.5"D (44mm x 431mm x 165mm)	1
HB0B1F1BN12H1	Horizontal power strip with a 20 A, 208V, 12 NEMA 6-20R receptacles, one 20 A double pole magnetic breaker/on-off switch with integral switch guard, and 10' power cord with NEMA L6-20P twist lock plug. UL and c-UL Listed. Dimensions: 1.7"H x 17.0"W x 6.5"D (43mm x 431mm x 165mm)	1
HB1B1E1BN12H1	Horizontal power strip with a 20 A, 208V, 12 NEMA 6-20R receptacles, one 20 A double pole magnetic breaker/on-off switch with integral switch guard, red LED current monitor, and 10' power cord with NEMA 6-20P plug. UL and c-UL Listed. Dimensions: 1.7"H x 17.0"W x 6.5"D (44mm x 431mm x 165mm)	1
HB1B1F1BN12H1	Horizontal power strip with a 20 A, 208V, 12 NEMA 6-20R receptacles, one 20 A double pole magnetic breaker/on-off switch with integral switch guard, red LED current monitor, and 10' power cord with NEMA L6-20P twist lock plug. UL and c-UL Listed. Dimensions: 1.7"H x 17"W x 6.5"D (44mm x 431mm x 165mm)	1
HB1B1E0BA08W1	Horizontal power strip with a 20 A, 208V, 4 IEC C-13 and 4 IEC C-19 receptacles, red LED current monitor, and 10' power cord with NEMA 6-20P plug. UL and c-UL Listed. Dimensions: 1.7"H x 17.0"W x 1.85"D (43mm x 431mm x 47mm)	1
HB1B1F0BA08W1	Horizontal power strip with a 20 A, 208V, 4 IEC C-13 and 4 IEC C-19 receptacles, red LED current monitor and 10' power cord with NEMA L6-20P twist lock plug. UL and c-UL Listed. Dimensions: 1.7"H x 17.0"W x 1.85"D (43mm x 431mm x 47mm)	1
HB0B1E0BA08W1	Horizontal power strip with a 20 A, 208V, 4 IEC C-13 and 4 IEC C-19 receptacles and 10' power cord with NEMA 6-20P plug. UL and c-UL Listed. Dimensions: 1.7"H x 17.0"W x 1.85"D (43mm x 431mm x 47mm)	1
HB0B1F0BA08W1	Horizontal power strip with a 20 A, 208V, 4 IEC C-13 and 4 IEC C-19 receptacles and 10' power cord with NEMA L6-20P twist lock plug. UL and c-UL Listed. Dimensions: 1.7"H x 17.0"W x 1.85"D (43mm x 431mm x 47mm)	1
2 RU Horizontal 20 AMP Straight Plug 208V without Power Meter		
HB0B1E0BA06J1	Horizontal power strip with a 20 A, 208V, 6 NEMA L6-20R receptacles and 10' power cord with NEMA 6-20P plug. UL and c-UL Listed. Dimensions: 3.4"H x 17.0"W x 6.0"D (86mm x 431mm x 155mm)	1
HB1B1E0BA06J1	Horizontal power strip with a 20 A, 208V, 6 NEMA L6-20R receptacles, red LED current monitor, and 10' power cord with NEMA 6-20P plug. UL and c-UL Listed. Dimensions: 3.4"H x 17.0"W x 6.0"D (86mm x 431mm x 155mm)	1
2 RU Horizontal 20 AMP Twist Lock Plug 208V with Power Meter		
HB1B1F0BA06J1	Horizontal power strip with a 20 A, 208V, 6 NEMA L6-20R receptacles, red LED current monitor, and 10' power cord with NEMA L6-20P twist lock plug. UL and c-UL Listed. Dimensions: 3.4"H x 17.0"W x 6.0"D (86mm x 431mm x 155mm)	1
HB0B1F0BA06J1	Horizontal power strip with a 20 A, 208V, 6 NEMA L6-20R receptacles and 10' power cord with NEMA L6-20P twist lock plug. UL and c-UL Listed. Dimensions: 3.4"H x 17.0"W x 6.0"D (86mm x 431mm x 155mm)	1

**For twist lock version replace 1E with 1F.

‡For non-metered versions, replace HB1 with HB0, i.e. HB0B1F0BA08W1.

Refer to www.panduit.com for detailed information on the complete line of power outlet units.

Basic and Metered Power Outlet Units (continued)



CMRPSV20

Part Number	Part Description	St. Pkg. Qty.
Vertical 20 AMP, Single Phase 120V		
CMRPSV20**	Vertical power strip with a 20 A, 120V, ten NEMA 5-20R receptacles, one 20 A thermal breaker, 10' power cord with NEMA 5-20P plug. UL and c-UL Listed. Dimensions: 38.5"H x 1.9"W x 1.3"D (978mm x 47mm x 33mm)	1
CMRPSVD20**	Vertical power strip with dual 20 A, 120V circuits, ten NEMA 5-20R receptacles per circuit, two 20 A thermal breakers, two 15' power cords with NEMA 5-20P plugs. UL and c-UL Listed. Dimensions: 66.3"H x 1.9"W x 1.3"D (1683mm x 47mm x 33mm)	1
Vertical 20 AMP with Surge Protection and in-line Receptacles 120V		
CMRPSV20SIL	Vertical power strip with a 20 A, 120V, 20 NEMA 5-20R in-line receptacles, one 20 A thermal breaker, red LED surge suppression indicator, and 10' power cord with NEMA 5-20P plug. UL and c-UL Listed. Dimensions: 66.3"H x 1.9"W x 1.6"D (1683mm x 47mm x 33mm)	1
CMRPSV20SILT	Vertical power strip with a 20 A, 120V, 20 NEMA 5-20R in-line receptacles, one 20 A thermal breaker, red LED surge suppression indicator, and 10' power cord with NEMA L5-20P twist lock plug. UL and c-UL Listed. Dimensions: 66.3"H x 1.9"W x 1.6"D (1683mm x 47mm x 33mm)	1
CMRPSV20SILM	Vertical power strip with a 20 A, 120V, 20 NEMA 5-20R in-line receptacles, one 20 A thermal breaker, red LED surge suppression indicator, red LED current monitor, and 10' power cord with NEMA 5-20P plug. UL and c-UL Listed. Dimensions: 66.3"H x 1.9"W x 1.6"D (1683mm x 47mm x 33mm)	1
CMRPSV20SILTLM	Vertical power strip with a 20 A, 120V, 20 NEMA 5-20R in-line receptacles, one 20 A thermal breaker, red LED surge suppression indicator, red LED current monitor, and 10' power cord with NEMA L5-20P twist lock plug. UL and c-UL Listed. Dimensions: 66.3"H x 1.9"W x 1.6"D (1683mm x 47mm x 33mm)	1
Vertical 20 AMP with Surge Protection and without Digital Monitor 120V		
CMRPSV20S	Vertical power strip with a 20 A, 120V, twenty NEMA 5-20R duplex receptacles, one 20 A thermal breaker, red LED surge suppression indicator, and 10' power cord with NEMA 5-20P plug. UL and c-UL Listed. Dimensions: 66.3"H x 1.9"W x 1.3"D (1683mm x 47mm x 33mm)	1
CMRPSV20STL	Vertical power strip with a 20 A, 120V, twenty NEMA 5-20R duplex receptacles, one 20 A thermal breaker, red LED surge suppression indicator, and 10' power cord with NEMA L5-20P twist lock plug. UL and c-UL Listed. Dimensions: 66.3"H x 1.9"W x 1.3"D (1683mm x 47mm x 33mm)	1
CMRPSV20SM	Vertical power strip with a 20 A, 120V, twenty NEMA 5-20R duplex receptacles, one 20 A thermal breaker, red LED surge suppression indicator, red LED current monitor, and 10' power cord with NEMA 5-20P plug. UL and c-UL Listed. Dimensions: 66.3"H x 1.9"W x 1.3"D (1683mm x 47mm x 33mm)	1
CMRPSV20STLM	Vertical power strip with a 20 A, 120V, twenty NEMA 5-20R duplex receptacles, one 20 A thermal breaker, red LED surge suppression indicator, red LED current monitor, and 10' power cord with NEMA L5-20P twist lock plug. UL and c-UL Listed. Dimensions: 66.3"H x 1.9"W x 1.3"D (1683mm x 47mm x 33mm)	1
CMRPSV20C139	Vertical power strip with 20 A, 120V, 24 IEC C-13 and 6 IEC C-19 receptacles, and 10' power cords with NEMA 5-20P plug. UL and c-UL Listed. Dimensions: 66.3"H x 2.0"W x 2.0"D (1683mm x 51mm x 51mm)	1
CMRPSV20C139TL	Vertical power strip with a 20 A, 120V, 24 IEC C-13 and 6 IEC C-19 receptacles, and 10' power cords with NEMA L5-20P twist lock plugs. UL and c-UL Listed. Dimensions: 66.3"H x 2.0"W x 2.0"D (1683mm x 51mm x 51mm)	1

**For Twist Lock Plug add "TL".

Refer to www.panduit.com for detailed information on the complete line of power outlet units.

Table continues on page L.38



VB0B1E0CA20H1



VB0A1J0BA24E1

Basic and Metered Power Outlet Units (continued)

Part Number	Part Description	Std. Pkg. Qty.
Vertical 20 AMP Dual Plug with and without Digital Monitor 208V		
VB0B1E0CA20H1	Vertical power strip with dual 20 A, 208V, ten NEMA 6-20R receptacles per circuit, two 10' power cords with NEMA 6-20P plugs. UL and c-UL Listed. Dimensions: 66.3"H x 1.9"W x 1.3"D (1683mm x 47mm x 33mm)	1
VB0B1F0CA20H1	Vertical power strip with dual 20 A, 208V, ten NEMA 6-20R receptacles per circuit, red LED current monitor and two 10' power cords with NEMA L6-20P twist lock plugs. UL and c-UL Listed. Dimensions: 66.3"H x 1.9"W x 1.3"D (1683mm x 47mm x 33mm)	1
VB1B1E0CA20H1	Vertical power strip with dual 20 A, 208V ten NEMA 6-20R receptacles per circuit, red LED current monitor per circuit, and two 10' power cords with NEMA 6-20P plugs. UL and c-UL Listed. Dimensions: 66.3"H x 1.9"W x 1.3"D (1683mm x 47mm x 33mm)	1
VB1B1F0CA20H1	Vertical power strip with dual 20 A, 208V ten NEMA 6-20R receptacles per circuit, red LED current monitor per circuit, and two 10' power cords with NEMA L6-20P twist lock plugs. UL and c-UL Listed. Dimensions: 66.3"H x 1.9"W x 1.3"D (1683mm x 47mm x 33mm)	1
Vertical 20 AMP 3 Phase 120V		
VB0A1J0BA24E1	Vertical power strip with a 20 A WYE, 120 V, 24 NEMA 5-20R receptacles and 10' power cord with NEMA L21-20P twist lock plug. UL and c-UL Listed. Dimensions: 66.3"H x 2.0"W x 2.0"D (1683mm x 51mm x 51mm)	1
VB1A1J0BA24E1	Vertical power strip with a 20 A WYE, 120V, 24 NEMA 5-20R receptacles, and 10' power cord with NEMA L21-20P twist lock plug. UL and c-UL Listed. Dimensions: 66.3"H x 2.0"W x 2.0"D (1683mm x 51mm x 51mm)	1
Vertical 20 AMP 3 Phase 120V		
VB0A1J0BA30P1	Vertical power strip with 20 A WYE, 120 V 24 IEC C-13 and 6 IEC C-19 receptacles and 10' power cord with NEMA L21-20P twist lock plug. UL and c-UL Listed. Dimensions: 66.3"H x 2.0"W x 2.0"D (1683mm x 51mm x 51mm)	1
VB1A1J0BA30P1	Vertical power strip with 20 A WYE, 120V, 24 IEC C-13 and 6 IEC C-19 receptacles, red LED current monitor, and 10' power cord with NEMA L21-20P twist lock plug. UL and c-UL Listed. Dimensions: 66.3"H x 2.0"W x 2.0"D (1683mm x 51mm x 51mm)	1
Vertical 20 AMP 3 Phase 208V		
VB0B1J0BA24H1	Vertical power strip with a 20 A WYE, 208V, 24 NEMA 6-20R receptacles and 10' power cord with NEMA 21-20P twist lock plug. UL and c-UL Listed. Dimensions: 66.3"H x 2.0"W x 2.0"D (1683mm x 51mm x 51mm)	1
VB1B1J0BA24H1	Vertical power strip with a 20 A WYE, 208V, 24 NEMA 6-20R receptacles, red LED current monitor, and 10' power cord with NEMA L21-20P twist lock plug. UL and c-UL Listed. Dimensions: 66.3"H x 2.0"W x 2.0"D (1683mm x 51mm x 51mm)	1

**For Twist Lock Plug add "TL".

Refer to www.panduit.com for detailed information on the complete line of power outlet units.

Basic and Metered Power Outlet Units (continued)



VB0C1J0BA30U1

Part Number	Part Description	Std. Pkg. Qty.
Vertical 20 AMP 3 Phase 208V		
VB1B1J0BA30P1	Vertical power strip with 20 A WYE, 208V, 24 IEC C-13 and 6 IEC C-19 receptacles, red LED current monitor, and 10' power cord with NEMA L21-20P twist lock plug. UL and c-UL Listed. Dimensions: 66.3"H x 2.0"W x 2.0"D (1683mm x 51mm x 51mm)	1
VB0C1J0BA30U1	Vertical power strip with a 20 A WYE, 208V, 24 NEMA 5-20R and 6 NEMA L6-20R receptacles and 10' power cord with NEMA L21-20P twist lock plug. UL and c-UL Listed. Dimensions: 66.3"H x 2.0"W x 2.0"D (1683mm x 51mm x 51mm)	1
VB1C1J0BA30U1	Vertical power strip with a 20 A WYE, 208V, 24 NEMA 5-20R and 6 NEMA L6-20R receptacles, red LED current monitor, and 10' power cord with NEMA L21-20P twist lock plug. UL and c-UL Listed. Dimensions: 66.3"H x 2.0"W x 2.0"D (1683mm x 51mm x 51mm)	1
VB0C1J0BA18V1	Vertical power strip with a 20 A WYE, 208V, 12 IEC C-13 and 6 NEMA 5-20R receptacles and 10' power cord with NEMA L21-20P twist lock plug. UL and c-UL Listed. Dimensions: 70.0"H x 2.0"W x 2.0"D (1778mm x 51mm x 51mm)	1
1 RU Horizontal 30 AMP with and without Digital Monitor 120V		
HB0A1M2BN12E1	Horizontal power strip 30 A, 120V, 12 NEMA 5-20R receptacles, two 20 A single pole magnetic breaker/on-off switch with integral switch guard, and 10' power cord with NEMA L5-30P twist lock plug. UL and c-UL Listed. Dimensions: 1.7"H x 17.0"W x 6.5"D (43mm x 431mm x 165mm)	1
HB1A1M2BN12E1	Horizontal power strip 30 A, 120V, 12 NEMA 5-20R receptacles, two 20 A single pole magnetic breaker/on-off switch with integral switch guard, LED current monitor, and 10' power cord with NEMA L5-30P twist lock plug. UL and c-UL Listed. Dimensions: 1.7"H x 17.0"W x 6.5"D (43mm x 431mm x 165mm)	1
HB0A1M2BT08W1	Horizontal power strip 30 A, 120V, 4 IEC C-13 and 4 IEC C-19 receptacles, two 15 A thermal breakers, and 10' power cord with NEMA L5-30P twist lock plug. UL and c-UL Listed. Dimensions: 1.7"H x 17.0"W x 1.85"D (43mm x 431mm x 47mm)	1
HB1A1M2BT08W1	Horizontal power strip 30 A, 120V, 4 IEC C-13 and 4 IEC C-19 receptacles, two 15 A thermal breakers, red LED current monitor, and 10' power cord with NEMA L5-30P twist lock plug. UL and c-UL Listed. Dimensions: 1.7"H x 17.0"W x 1.85"D (43mm x 431mm x 47mm)	1
HB0A1M2BT10M1	Horizontal power strip 30 A, 120V, 10 IEC C-13 receptacles, two 15 A thermal breakers and 10' power cord with NEMA L5-30P twist lock plug. UL and c-UL Listed. Dimensions: 1.7"H x 17.0"W x 1.6"D (43mm x 431mm x 41mm)	1
HB1A1M2BT10M1	Horizontal power strip 30 A, 120V, 10 IEC C-13 receptacles, two 15 A thermal breakers, red LED current monitor, and 10' power cord with NEMA L5-30P twist lock plug. UL and c-UL Listed. Dimensions: 1.7"H x 17.0"W x 1.6"D (43mm x 431mm x 41mm)	1

**For Twist Lock Plug add "TL".

Refer to www.panduit.com for detailed information on the complete line of power outlet units.

Table continues on page L.40

Basic and Metered Power Outlet Units (continued)

Part Number	Part Description	Std. Pkg. Qty.
2 RU Horizontal 30 AMP with and without Digital Monitor 120V		
HB0A1M2BN06G1	Horizontal power strip 30 A, 120V, 6 NEMA L5-20R receptacles, two 20 A double pole magnetic breaker/on-off switch with integral switch guard, and 10' power cord with NEMA L5-30P twist lock plug. UL and c-UL Listed. Dimensions: 3.4"H x 17.0"W x 6.0"D (86mm x 431mm x 152mm)	1
HB1A1M2BN06G1	Horizontal power strip 30 A, 120V, 6 NEMA L5-20R receptacles, two 20 A double pole magnetic breaker/on-off switch with integral switch guard, red LED current monitor, and 10' power cord with NEMA L5-30P twist lock plug. UL and c-UL Listed. Dimensions: 3.4"H x 17.0"W x 6.0"D (86mm x 431mm x 152mm)	1
HB0A1M0BA06K1	Horizontal power strip 30 A, 120V, 6 NEMA L5-30R receptacles, and 10' power cord with NEMA L5-30P twist lock plug. UL and c-UL Listed. Dimensions: 3.4"H x 17.0"W x 6.0"D (86mm x 431mm x 152mm)	1
HB1A1M0BA06K1	Horizontal power strip with a 30 A, 120V, 6 NEMA L5-30R receptacles, red LED current monitor, and 10' power cord with NEMA L5-30P twist lock plug. UL and c-UL Listed. Dimensions: 3.4"H x 17.0"W x 6.0"D (86mm x 431mm x 152mm)	1
1 RU Horizontal 30 AMP with and without Digital Monitor 208V		
HB0B1L4BT10M1	Horizontal power strip 30 A, 208V, 10 IEC C-13 receptacles, four 15 A thermal breakers, and 10' power cord with NEMA L6-30P twist lock plug. UL and c-UL Listed. Dimensions: 1.7"H x 17.0"W x 1.6"D (43mm x 431mm x 41mm)	1
HB1B1L4BT10M1	Horizontal power strip 30 A, 208V, 10 IEC C-13 receptacles, four 15 A thermal breakers, red LED current monitor, and 10' power cord with NEMA L6-30P twist lock plug. UL and c-UL Listed. Dimensions: 1.7"H x 17.0"W x 1.6"D (43mm x 431mm x 41mm)	1
HB0B1L2BN12H1	Horizontal power strip 30 A, 208V, 12 NEMA 6-20R receptacles, two 20 A double pole magnetic breaker/on-off switch with integral guard, and 10' power cord with NEMA L6-30P twist lock plug. UL and c-UL Listed. Dimensions: 1.7"H x 17.0"W x 6.5"D (43mm x 431mm x 165mm)	1
HB1B1L2BN12H1	Horizontal power strip 30 A, 208V, 12 NEMA 6-20R receptacles, two 20 A double pole magnetic breaker/on-off switch with integral guard, red LED current monitor, and 10' power cord with NEMA L6-30P twist lock plug. UL and c-UL Listed. Dimensions: 1.7"H x 17.0"W x 6.5"D (43mm x 431mm x 165mm)	1
HB0B1L4BT08W1	Horizontal power strip 30 A, 208V, 4 IEC C-13 and 4 IEC C-19 receptacles, four 15 A thermal breakers and 10' power cord with NEMA L6-30P twist lock plug. UL and c-UL Listed. Dimensions: 1.7"H x 17.0"W x 1.85"D (43mm x 431mm x 47mm)	1
HB1B1L4BT08W1	Horizontal power strip 30 A, 208V, 4 IEC C-13 and 4 IEC C-19 receptacles, four 15 A thermal breakers, red LED current monitor, and 10' power cord with NEMA L6-30P twist lock plug. UL and c-UL Listed. Dimensions: 1.7"H x 17.0"W x 1.85"D (43mm x 431mm x 47mm)	1

**For twist lock version replace 1E with 1F.

‡For non-metered versions, replace HB1 with HB0, i.e. HB0B1F0BA08W1.

Refer to www.panduit.com for detailed information on the complete line of power outlet units.

Basic and Metered Power Outlet Units (continued)

Part Number	Part Description	Std. Pkg. Qty.
2 RU Horizontal 30 AMP with and without Digital Monitor 208V		
HB0B1L2BN06J1	Horizontal power strip with a 30 A, 208V, 6 NEMA L6-20R receptacles, two 20 A double pole magnetic breaker/on-off switch with integral switch guard, and 10' power cord with NEMA L6-30P twist lock plug. UL and c-UL Listed. Dimensions: 3.4"H x 17.0"W x 6.0"D (86mm x 431mm x 152mm)	1
HB1B1L2BN06J1	Horizontal power strip with a 30 A, 208V, 6 NEMA L6-20R receptacles, two 20 A double pole magnetic breaker/on-off switch with integral switch guard, red LED current monitor, and 10' power cord with NEMA L6-30P twist lock plug. UL and c-UL Listed. Dimensions: 3.4"H x 17.0"W x 6.0"D (86mm x 431mm x 152mm)	1
HB0B1L0BA06L1	Horizontal power strip with a 30 A, 208V, 6 NEMA L6-30R receptacles, and 10' power cord with NEMA L6-30P twist lock plug. UL and c-UL Listed. Dimensions: 3.4"H x 17.0"W x 6.0"D (86mm x 431mm x 152mm)	1
HB1B1L0BA06L1	Horizontal power strip with a 30 A, 208 V, 6 NEMA L6-30R receptacles, red LED current monitor, and 10' power cord with NEMA L6-30P twist lock plug. UL and c-UL Listed. Dimensions: 3.4"H x 17.0"W x 6.0"D (86mm x 431mm x 152mm)	1
Vertical 30 AMP with and without Digital Monitor 120V		
VB0A1M2BM30P1	Vertical power strip 30 A, 120V, 24 IEC C-13 and 6 IEC C-19 receptacles, two 20 A single pole magnetic breaker/on-off switch with integral switch guard, and 10' power cord with NEMA L5-30P twist lock plug. UL and c-UL Listed. Dimensions: 66.3"H x 2.0"W x 2.0"D Breaker Doghouse add 1.44" (87.4mm) to overall depth (1683mm x 51mm x 51mm)	1
VB1A1M2BM30P1	Vertical power strip 30 A, 120V, 24 IEC C-13 and 6 IEC C-19 receptacles, two 20 A single pole magnetic breaker/on-off switch with integral switch guard, red LED current monitor, and 10' power cord with NEMA L5-30P twist lock plug. UL and c-UL Listed. Dimensions: 66.3"H x 2.0"W x 2.0"D Breaker Doghouse add 1.44" (87.4mm) to overall depth (1683mm x 51mm x 51mm)	1
VB0A1M2BM24E1	Vertical power strip 30 A, 120 V, 24 NEMA 5-20R receptacles, two 20 A single pole magnetic breaker/on-off switch with integral switch guard, and 10' power cord with NEMA L5-30P twist lock plug. UL and c-UL Listed. Dimensions: 66.3"H x 2.0"W x 2.0"D Breaker Doghouse add 1.44" (87.4mm) to overall depth (1683mm x 51mm x 51mm)	1
VB1A1M2BM24E1	Vertical power strip with dual 30 A, 120V, 24 NEMA 5-20R receptacles, two 20 A single pole magnetic breaker/on-off switch with integral switch guard, red LED current monitor, and 10' power cord with NEMA L5-30P twist lock plug. UL and c-UL Listed. Dimensions: 66.3"H x 2.0"W x 2.0"D Breaker Doghouse add 1.44" (87.4mm) to overall depth (1683mm x 51mm x 51mm)	1
Vertical 30 AMP, Dual Plug with and without Digital Monitor 120V		
VB0A1M2CN24E1	Vertical power strip with dual 30 A, 120V twenty-four NEMA 5-20R receptacles per circuit, two 20 A double pole magnetic breaker/on-off switch with integral switch guard, and two 10' power cords with NEMA L5-30P twist lock plugs. UL and c-UL Listed. Dimensions: 66.3"H x 2.0"W x 2.0"D Breaker Doghouse add 1.44" (87.4mm) to overall depth (1683mm x 51mm x 51mm)	1
VB1A1M2CN24E1	Vertical power strip with dual 30 A, 120V twenty-four NEMA 5-20R receptacles per circuit, two 20 A double pole magnetic breaker/on-off switch with integral switch guard, red LED current monitor, and two 10' power cords with NEMA L5-30P twist lock plugs. UL and c-UL Listed. Dimensions: 66.3"H x 2.0"W x 2.0"D Breaker Doghouse add 1.44" (87.4mm) to overall depth (1683mm x 51mm x 51mm)	1
Vertical 30 AMP Dual Plug with and without Digital Monitor 208V		
VB1B1L4CN48M1	Vertical power strip 30 Amp, 208V, 48 IEC C-13 receptacles, four 20 Amp double pole magnetic breaker/on-off switch with integral switch guard, two red LED current monitors, and dual 10' power cord with NEMA L6-30P twist lock plugs. UL and c-UL Listed. Dimensions: 66.3"H x 3.5"W x 2.0"D Breaker Doghouse add 1.44" (87.4mm) to overall depth (1683mm x 89mm x 51mm).	1



VB0A1M2BM30P1



VB0A1P3BN24E1

**For Twist Lock Plug add "TL".

Refer to www.panduit.com for detailed information on the complete line of power outlet units.

Table continues on page L.42



VB1B1L2BN24H1

Basic and Metered Power Outlet Units (continued)

Part Number	Part Description	Std. Pkg. Qty.
Vertical 30 AMP with and without Digital Monitor 208V		
VB0B1L4BT24M1	Vertical power strip 30 A, 208V, 24 IEC C-13 receptacles, four 15 A thermal breakers, and 10' power cord with NEMA L6-30P twist lock plug. UL and c-UL Listed. Dimensions: 66.3"H x 1.7"W x 1.7"D Breaker Doghouse add 1.44" (87.4mm) to overall depth (1683mm x 44mm x 44mm)	1
VB1B1L4BT24M1	Vertical power strip 30 A, 208V, 24 IEC C-13 receptacles, four 15 A thermal breakers, red LED current monitor, and 10' power cord with NEMA L6-30P twist lock plug. UL and c-UL Listed. Dimensions: 66.3"H x 1.7"W x 1.7"D Breaker Doghouse add 1.44" (87.4mm) to overall depth (1683mm x 44mm x 44mm)	1
VB1B1L2BN24H1	Vertical power strip 30 A, 208V, 24 NEMA 6-20R receptacles, two 20 A double pole magnetic breaker/on-off switch with integral switch guard, red LED current monitor, and 10' power cord with NEMA L6-30P twist lock plug. UL and c-UL Listed. Dimensions: 66.3"H x 2.0"W x 2.0"D Breaker Doghouse add 1.44" (87.4mm) to overall depth (1683mm x 51mm x 51mm)	1
VB0B1L2BN12J1	Vertical power strip 30 A, 208V, 12 NEMA L6-20R receptacles, two 20 A double pole magnetic breaker/on-off switch with integral switch guard, and 10' power cord with NEMA L6-30P twist lock plug. UL and c-UL Listed. Dimensions: 66.3"H x 2.0"W x 2.0"D Breaker Doghouse add 1.44" (87.4mm) to overall depth (1683mm x 51mm x 51mm)	1
VB1B1L2BN12J1	Vertical power strip 30 A, 208V, 12 NEMA L6-20R receptacles, two 20 A double pole magnetic breaker/on-off switch with integral switch guard, red LED current monitor, and 10' power cord with NEMA L6-30P twist lock plug. UL and c-UL Listed. Dimensions: 66.3"H x 2.0"W x 2.0"D Breaker Doghouse add 1.44" (87.4mm) to overall depth (1683mm x 51mm x 51mm)	1
VB1B1L4CN48M1	Vertical power strip with 30 A, 208V, 48 IEC C-13 receptacles, four 20 A double pole magnetic breaker /on-off switch with integral switch guard, two red LED current monitors and dual 10' power cord with NEMA L6-30P twist lock plugs. UL and c-UL Listed. Dimensions: 66.3"H x 3.5"W x 2.0"D (1683mm x 89mm x 51mm)	1
Vertical 30 AMP, 3 Phase WYE 120V		
VB0A1P3BN24E1	Vertical power strip 30 A, 120V WYE, 24 NEMA 5-20R receptacles, three 20 A double pole magnetic breaker/on-off switch with integral switch guard, and 10' power cord with NEMA L21-30P twist lock plug. UL and c-UL Listed. Dimensions: 66.3"H x 2.0"W x 2.0"D Breaker Doghouse add 1.44" (87.4mm) to overall depth (1683mm x 51mm x 51mm)	1
VB1A1P3BN24E1‡	Vertical power strip 30 A, 120V, 24 NEMA 5-20R receptacles, three 20 A double pole magnetic breaker/on-off switch with integral switch guard, red LED current monitor, and 10' power cord with NEMA L21-30P twist lock plug. UL and c-UL Listed. Dimensions: 66.3"H x 2.0"W x 2.0"D Breaker Doghouse add 1.44" (87.4mm) to overall depth (1683mm x 51mm x 51mm)	1
VB1A1P3BN30P1‡	Vertical power strip 30 A, 120V WYE, 24 IEC C-13 and 6 IEC C-19 receptacles, three 20 A double pole magnetic breaker/on-off switch with integral switch guard, red LED current monitor, and 10' power cord with NEMA L21-30P twist lock plug. UL and c-UL Listed. Dimensions: 66.3"H x 2.0"W x 2.0"D Breaker Doghouse add 1.44" (87.4mm) to overall depth (1683mm x 51mm x 51mm)	1
VB1A1P3BN12G1‡	Vertical power strip 30 A, 120V WYE, 12 NEMA L5-20R receptacles, three 20 A double pole magnetic breaker/on-off switch with integral switch guard, red LED current monitor, and 10' power cord with NEMA L21-30P twist lock plug. UL and c-UL Listed. Dimensions: 66.3"H x 2.0"W x 2.0"D Breaker Doghouse add 1.44" (87.4mm) to overall depth (1683mm x 51mm x 51mm)	1

‡For non-metered versions, replace VB1 with VB0, i.e. VB0A1P3BN24E1

Refer to www.panduit.com for detailed information on the complete line of power outlet units.

Basic and Metered Power Outlet Units (continued)



VB1B1P3BN24H1

Part Number	Part Description	Std. Pkg. Qty.
Vertical 30 AMP, 3 Phase WYE 208V		
VB1B1P3BN24H1‡	Vertical power strip 30 A, 208V WYE, 24 NEMA 6-20R receptacles, three 20 A double pole magnetic breaker/on-off switch with integral switch guard, red LED current monitor, and 10' power cord with NEMA L21-30P twist lock plug. UL and c-UL Listed. Dimensions: 66.3"H x 2.0"W x 2.0"D Breaker Doghouse add 1.44" (87.4mm) to overall depth (1683mm x 51mm x 51mm)	1
VB1B1P3BN12J1‡	Vertical power strip 30 A, 208V WYE, 12 NEMA L6-20R receptacles, three 20 A double pole magnetic breaker/on-off switch with integral switch guard, red LED current monitor, and 10' power cord with NEMA L21-30P twist lock plug. UL and c-UL Listed. Dimensions: 66.3"H x 2.0"W x 2.0"D Breaker Doghouse add 1.44" (87.4mm) to overall depth (1683mm x 51mm x 51mm)	1
VB1A1P3BN30P1‡	Vertical power strip 30 A, 120V WYE, 24 IEC C-13 and 6 IEC C-19 receptacles, three 20 A double pole magnetic breaker/on-off switch with integral switch guard, red LED current monitor, and 10' power cord with NEMA L21-30P twist lock plug. UL and c-UL Listed. Dimensions: 66.3"H x 2.0"W x 2.0"D Breaker Doghouse add 1.44" (87.4mm) to overall depth (1683mm x 51mm x 51mm)	1
Vertical 30 AMP, 3 Phase WYE 120/208V		
VB0C1P3BN33X1	Vertical power strip 30 A, 120/208V WYE, 24 IEC C-13 and 3 IEC C-19 and 6 NEMA 5-20R receptacles, three 20 A double pole magnetic breaker/on-off switch, with integral switch guard, and 10' power cord with NEMA L21-30P twist lock plug. UL and c-UL Listed. Dimensions: 66.3"H x 2.0"W x 2.0"D Breaker Doghouse add 1.44" (87.4mm) to overall depth (1683mm x 51mm x 51mm)	1
VB0C1P3BN24Y1	Vertical power strip 30 A, 120/208V WYE, 12 IEC C-13 and 6 IEC C-19 and 6 NEMA 5-20R, receptacles, three 20 A double pole magnetic breaker/on-off switch, with integral switch guard, and 10' power cord with NEMA L21-30P twist lock plug. UL and c-UL Listed. Dimensions: 70"H x 2.0"W x 2.0"D Breaker Doghouse add 1.44" (87.4mm) to overall depth (1777mm x 51mm x 51mm)	1
Vertical 30 AMP, 3 Phase WYE 230/400V		
VB1D1Q3BN30P1‡	Vertical power strip 30 A, 230/400V WYE, 24 IEC C-13 and 6 IEC C-19 receptacles, three 20 A double pole magnetic breaker/on-off switch with integral switch guard, red LED current monitor, and 10' power cord with NEMA L22-30P twist lock plug. UL and c-UL Listed. Dimensions: 66.3"H x 2.0"W x 2.0"D Breaker Doghouse add 1.44" (87.4mm) to overall depth (1683mm x 51mm x 51mm)	1
Vertical 30 AMP, 3 Phase Delta 208V		
VB1B1N3BN24H1‡	Vertical power strip 30 A, 208V Delta, 24 NEMA 6-20R receptacles, three 20 A double pole magnetic breaker/on-off switch with integral switch guard, red LED current monitor, and 10' power cord with NEMA L15-30P twist lock plug. UL and c-UL Listed. Dimensions: 66.3"H x 2.0"W x 2.0"D Breaker Doghouse add 1.44" (87.4mm) to overall depth (1683mm x 51mm x 51mm)	1
VB1B1N3BN12J1‡	Vertical power strip 30 A, 208V Delta, 12 NEMA L6-20R receptacles, three 20 A double pole magnetic breaker/on-off switch with integral switch guard, red LED current monitor, and 10' power cord with NEMA L15-30P twist lock plug. UL and c-UL Listed. Dimensions: 66.3"H x 2.0"W x 2.0"D Breaker Doghouse add 1.44" (87.4) to overall depth (1683mm x 51mm x 51mm)	1
VB1B1N3BN30P1‡	Vertical power strip 30 A, 208V Delta, 24 IEC C-13 and 6 IEC C-19 receptacles, three 20 A double pole magnetic breaker/on-off switch with integral switch guard, red LED current monitor, and 10' power cord with NEMA L15-30P twist lock plug. UL and c-UL Listed. Dimensions: 66.3"H x 2.0"W x 2.0"D Breaker Doghouse add 1.44" (87.4) to overall depth (1683mm x 51mm x 51mm)	1

‡For Twist Lock Plug add "TL".

Refer to www.panduit.com for detailed information on the complete line of power outlet units.

Table continues on page L.44

Basic and Metered Power Outlet Units (continued)

VB0B2C3BN30P1

Part Number	Part Description	Std. Pkg. Qty.
60 Amp with and without Digital Monitor 208V		
VB0B2C3BN30P1	Vertical power strip 60 A, 208V, 24 IEC C-13 and 6 IEC C-19 receptacles, three 20 A double pole magnetic breaker/on-off switch with integral switch guard, and 10' power cord with IEC 60309 – 2P+E pin in sleeve water tight connector. UL and c-UL Listed. Dimensions: 66.3"H x 2.0"W x 2.0"D Breaker Doghouse add 1.44" (87.4mm) to overall depth (1683mm x 51mm x 51mm)	1
VB1B2C3BN30P1	Vertical power strip 60 A, 208V, 24 IEC C-13 and 6 IEC C-19 receptacles, three 20 A double pole magnetic breaker/on-off switch with integral switch guard, red LED current monitor, and 10' power cord with IEC 60309 – 2P+E pin in sleeve water tight connector. UL and c-UL Listed. Dimensions: 66.3"H x 2.0"W x 2.0"D Breaker Doghouse add 1.44" (87.4mm) to overall depth (1683mm x 51mm x 51mm)	1
Horizontal 60 AMP without Digital Monitor 208V		
HB0B2C3BN03N1	Horizontal power strip 60 A, 208V, 3 IEC C-19 receptacles, three 20 A double pole magnetic breaker/on-off switch with integral switch guard and 10' power cord with IEC 60309 – 2P+E pin in sleeve water tight connector. UL and c-UL Listed. Dimensions: 1.7"H x 17.0"W x 6.5"D (43mm x 431mm x 165mm)	1
Vertical 60 AMP, 3 Phase Delta 208V		
VB0B2G6BN12N1	Vertical power strip 60 A, 208V, Delta, 12 IEC C-19 receptacles, six 20 A double pole magnetic breaker on-off switch with integral switch guard, and 10' power cord with IEC 60309 3P+E pin and sleeve connector. UL and c-UL Listed. Dimensions: 66.3"H x 2"W x 3.5"D (1683mm x 51mm x 89mm)	1
VB0B2G6BN24Z1	Vertical power strip 60 A, 208V, Delta, 12 IEC C-13 and 12 IEC C-19 receptacles, six 20 A double pole magnetic breaker on-off switch with integral switch guard, and 10' power cord with IEC 60309 – 3P+E pin in sleeve connector. UL and c-UL Listed. Dimensions: 66.3"H x 2.3"W x 3.5"D (1683mm x 58mm x 89mm)	1
Vertical 80 AMP, 3 Phase Delta 208V		
VB0B6A4AP12N1	Vertical power strip 80 A, 208V, Delta, 12 IEC C-19 receptacles, four 20 A triple pole magnetic breaker on-off switch with integral switch guard, and hardwired – wiring access panel conduit connection. UL and c-UL Listed. Dimensions: 66.3"H x 3.5"W x 3.5"D (1683mm x 89mm x 89mm)	1

‡For non-metered versions, replace VB1 with VB0, i.e. VB0A1P3BN24E1

Refer to www.panduit.com for detailed information on the complete line of power outlet units.

Auto Transfer Switch (ATS) Units

- Scrolling power meter providing critical information on current draw
- Switches from the primary to the secondary power source
- Dual input power sources for redundancy



HA1AC0CA10E1

Part Number	Part Description	Std. Pkg. Qty.
Horizontal Auto Transfer Switch 20 AMP with and without Digital Monitor 120V		
HA1A1C0CA10E1	Horizontal auto transfer switch 20 A, 120V, 10 NEMA 5-20R receptacles, two LEDs power-on indicators with red LED current monitor, and dual 10' power cord with NEMA 5-20P plug. UL and c-UL Listed. Power Feeds A and B must be Phase Synchronized. Dimensions: 1.72"H x 17.0"W x 9.0"D (44mm x 431mm x 229mm)	1
HA0A1C0CA10E1	Horizontal auto transfer switch 20 A, 120 V, 10 NEMA 5-20R receptacles, two LEDs power-on indicators, and dual 10' power cord with NEMA 5-20P plug. UL and c-UL Listed. Power Feeds A and B must be Phase Synchronized. Dimensions: 1.72"H x 17.0"W x 9.0"D (44mm x 431mm x 229mm)	1
HA1A1D0CA10E1	Horizontal auto transfer switch 20 A, 120V, 10 NEMA 5-20R receptacles, two LEDs power-on indicators with red LED current monitor, and dual 10' power cord with NEMA L5-20P twist lock plug. UL and c-UL Listed. Power Feeds A and B must be Phase Synchronized. Dimensions: 1.72"H x 17.0"W x 9.0"D (44mm x 431mm x 229mm)	1
HA0A1D0CA10E1	Horizontal auto transfer switch 20 A, 120V, 10 NEMA 5-20R receptacles, two LEDs power-on indicators, and dual 10' power cord with NEMA L5-20P twist lock plug. UL and c-UL Listed. Power Feeds A and B must be Phase Synchronized. Dimensions: 1.72"H x 17.0"W x 9.0"D (44mm x 431mm x 229mm)	1
Horizontal Auto Transfer Switch 30 AMP with Digital Monitor 120V		
HA1A1M2CM10E1	Horizontal auto transfer switch 30 A, 120 V, 10 NEMA 5-20R receptacles, two LEDs power-on indicators with red LED current monitor, two 20 A single pole magnetic breaker on-off switch with integral switch guard and, dual 10' power cord with NEMA L5-30P twist lock plugs. UL and c-UL Listed. Power Feeds A and B must be Phase Synchronized. Dimensions: 1.72"H x 17.0"W x 9.0"D (44mm x 431mm x 229mm)	1
HA0A1M2CM10E1	Horizontal auto transfer switch 30 A, 120V, 10 NEMA 5-20R receptacles, two LEDs power-on indicators with two 20 A single pole magnetic breaker on-off switch with integral switch guard, and dual 10' power cord with NEMA L5-30P twist lock plugs. UL and c-UL Listed. Power Feeds A and B must be Phase Synchronized. Dimensions: 1.72"H x 17.0"W x 9.0"D (44mm x 431mm x 229mm)	1

Refer to www.panduit.com for detailed information on the complete line of power outlet units.

Networked Power Outlet Units

- Remote access to power consumption data via a web-based GUI provides global network access to real-time power information
- Integrates with Panduit[®] PIM™ Software, which aggregates power information through a single web based GUI interface
- Integrated power monitoring and management with on unit display provides true RMS input current load (in amps) for each power circuit or phase to properly load balance and maximize power circuits
- Provides user-defined alarm/messaging capabilities for specific events that exceeded thresholds
- Mounting buttons allow tool-less installation of power strips

**QZ1B1P3BN30P1**

Part Number	Part Description	Std. Pkg. Qty.
Horizontal 20 Amp, 120V Networked Aggregate Monitoring		
PZ1A1C0BA20E1	2 RU horizontal power strip 20 A, 120V, 20 NEMA 5-20R receptacles, RJ-45 Ethernet port with red LED current monitor, and 10' power cord with NEMA 5-20P plug. UL and c-UL Listed. Dimensions: 3.4"H x 1.7"W x 6.0"D (86mm x 43mm x 152mm)	1
PZ1A1D0BA20E1	2 RU Horizontal power strip 20 A, 120V, 20 NEMA 5-20R receptacles, RJ-45 Ethernet port with red LED current monitor, and 10' power cord, NEMA L5-20P twist lock plug. UL and c-UL Listed. Dimensions: 3.4"H x 1.7"W x 6.0"D (86mm x 43mm x 152mm)	1
Vertical 20 AMP, 120V Networked Aggregate Monitoring		
QZ1A1C0BA24E1*	Vertical power strip 20 A, 120V, 24 NEMA 5-20R receptacles, RJ-45 Ethernet port with red LED current monitor, and 10' power cord with NEMA 5-20P plug. UL and c-UL Listed. Dimensions: 66.3"H x 2.0"W x 2.0"D (1683mm x 51mm x 51mm)	1
QZ1A1C0BA30P1*	Vertical power strip 20 A, 120V, 24 IEC C-13 and 6 IEC C-19 receptacles, RJ-45 Ethernet port with red LED current monitor, and 10' power cord with NEMA 5-20P plug. UL and c-UL Listed. Dimensions: 66.3"H x 2.0"W x 2.0"D (1683mm x 51mm x 51mm)	1
Vertical 20 AMP, 208V Networked Aggregate Monitoring		
QZ1B1E0BA30P1‡	Vertical power strip 20 A, 208V, 24 IEC C-13 and 6 IEC C-19 receptacles, RJ-45 Ethernet port with red LED current monitor, and 10' power cord with NEMA 6-20P plug. UL and c-UL Listed. Dimensions: 66.3"H x 2.0"W x 2.0"D (1683mm x 51mm x 51mm)	1
QZ1B1E0BA24H1‡	Vertical power strip 20 A, 208V, 24 NEMA 6-20R receptacles, RJ-45 Ethernet port with red LED current monitor, and 10' power cord with NEMA 6-20P plug. UL and c-UL Listed. Dimensions: 66.3"H x 2.0"W x 2.0"D (1683mm x 51mm x 51mm)	1
Vertical 20 AMP, 3 Phase WYE 120V Networked Circuit (X, Y, Z) Monitoring		
QZ1A1J0BA30P1	Vertical power strip 20 A, 120V WYE, 24 IEC C-13 and 6 IEC C-19 receptacles RJ-45 Ethernet port with red LED current monitor and, 10' power cord with NEMA L21-20P twist lock plug. UL and c-UL Listed. Dimensions: 66.3"H x 2.0"W x 2.0"D (1683mm x 51mm x 51mm)	1
Vertical 20 AMP, 3 Phase WYE 208V Networked Circuit (XY, YZ, ZX) Monitoring		
QZ1B1J0BA30P1	Vertical power strip 20 A, 208V WYE, 24 IEC C-13 and 6 IEC C-19 receptacles RJ-45 Ethernet port with red LED current monitor, and 10' power cord with NEMA L21-20P twist lock plug. UL and c-UL Listed. Dimensions: 66.3"H x 2.0"W x 2.0"D (1683mm x 51mm x 51mm)	1
Vertical 20 AMP, 3 Phase WYE 230/400V Networked Circuit Phase (X,Y, Z) Monitoring		
QZ1D1K0BA30P1	Vertical power strip 20 A, 230/400V, WYE, 24 IEC C-13 and 6 IEC C-19 receptacles, RJ-45 Ethernet port with red LED current monitor, and 10' power cord with NEMA L22-20P twist lock plug. UL and c-UL Listed. Dimensions: 66.3"H x 2.0"W x 2.0"D (1683mm x 51mm x 51mm)	1

*For NEMA L5-20P twist lock plug, replace "C" with "D", i.e. QZ1A1D0BA24E1.

‡For NEMA L6-20P twist lock plug, replace "E" with "F", i.e. QZ1B1F0BA30P1.

Networked Power Outlet Units (continued)



QZ1B1P3BN30P1

Part Number	Part Description	Std. Pkg. Qty.
Vertical 30 AMP, 120V Networked Aggregate/Breaker Monitoring		
QZ1A1M2BM24E1	Vertical power strip 30 A, 120V, 24 NEMA 5-20R receptacles, RJ-45 Ethernet port with red LED current monitor two, 20 A single pole magnetic breaker on-off switch with integral switch guard, and 10' power cord with NEMA L5-30P twist lock plug. UL and c-UL Listed. Dimensions: 66.3"H x 2.0"W x 2.0"D Breaker Doghouse add 1.44" (87.4mm) to overall depth (1683mm x 51mm x 51mm)	1
Vertical 30 AMP, 208V Networked Aggregate/Breaker Monitoring		
QZ1B1L2BN24H1	Vertical power strip 30 A, 208V, 24 NEMA 6-20R receptacles, RJ-45 Ethernet port with red LED current monitor, two 20 A double pole magnetic breaker on-off switch with integral switch guard, and 10' power cord with NEMA L6-30P twist lock plug. UL and c-UL Listed. Dimensions: 66.3"H x 2.0"W x 2.0"D Breaker Doghouse add 1.44" (87.4mm) to overall depth (1683mm x 51mm x 51mm)	1
Half Height Vertical 30 AMP, 208V Networked Aggregate/Breaker Monitoring		
QZ1B1L2BN1441	Vertical power strip 30 A, 208V, 12 IEC C-13 and 2 IEC C-19 receptacles, RJ-45 Ethernet port with red LED current monitor, two 20 A double pole magnetic breaker on-off switch with integral switch guard, and 10' power cord with NEMA L6-30P twist lock plug. UL and c-UL Listed. Dimensions: 33.0"H x 2.0"W x 2.0"D Breaker Doghouse add 1.44" (87.4mm) to overall depth (838mm x 51mm x 51mm)	1
Vertical 30 AMP, 3 Phase WYE 120V Networked Phase/Breaker (X,Y, Z) Monitoring		
QZ1A1P3BN30P1‡‡	Vertical power strip 30 A, 120V, WYE 24 IEC C-13 and 6 IEC C-19 receptacles, RJ-45 Ethernet port with red LED current monitor, three 20 A double pole magnetic breaker on-off switch with integral switch guard and 10' power cord with NEMA L21-30P twist lock plug. UL and c-UL Listed. Dimensions: 66.3"H x 2.0"W x 2.0"D Breaker Doghouse add 1.44" (87.4mm) to overall depth (1683mm x 51mm x 51mm)	1
Vertical 30 AMP, 3 Phase WYE 120/208V Networked Circuit/Breaker (XY,YZ,ZX) Monitoring		
QZ1C1P3BN33X1	Vertical power strip 30 A, 120/208V WYE, 24 IEC C-13 and 3 IEC C-19 and 6 NEMA 5-20R, receptacles, RJ-45 Ethernet port with red LED current monitor, three 20 A double pole magnetic breaker on-off switch with integral switch guard and 10' power cord with NEMA L21-30P twist lock plug. UL and c-UL Listed. Dimensions: 66.3"H x 2.0"W x 2.0"D Breaker Doghouse add 1.44" (87.4mm) to overall depth (1683mm x 51mm x 51mm)	1
QZ1C1P3BN24Y1	Vertical power strip 30 A, 120/208V WYE, 12 IEC C-13 and 6 IEC C-19 and 6 NEMA 5-20R, receptacles, RJ-45 Ethernet port with red LED current monitor, three 20 A double pole magnetic breaker on-off switch with integral switch guard and 10' power cord with NEMA L21-30P twist lock plug. UL and c-UL Listed. Dimensions: 70"H x 2.0"W x 2.0"D Breaker Doghouse add 1.44" (87.4mm) to overall depth (1777mm x 51mm x 51mm)	1
Vertical 30 AMP, 3 Phase WYE 120/208V Networked Circuit/Breaker (XY, YZ, ZX) and Outlet Monitoring		
QQ1C1P3BN24Y1	Vertical power strip 30 A, 120/208V WYE, 12 IEC C-13 and 6 IEC C-19 and 6 NEMA 5-20R, receptacles, RJ-45 Ethernet port with red LED current monitor, three 20 A double pole magnetic breaker on-off switch with integral switch guard and 10' power cord with NEMA L21-30P twist lock plug. UL and c-UL Listed. Dimensions: 70"H x 2.0"W x 2.0"D Breaker Doghouse add 1.44" (87.4mm) to overall depth (1777mm x 51mm x 51mm)	1

‡‡For Delta, replace "P" with "N", i.e. QZ1B1N3BN30P1.

Table continues on page L.48

Networked Power Outlet Units (continued)**QZ1C1P3BN1851**

Part Number	Part Description	Std. Pkg. Qty.
Half Height Vertical 30 AMP, 3 Phase WYE 120/208V Networked Circuit/Breaker (XY, YZ, ZX) Monitoring		
QZ1C1P3BN1851	Vertical power strip 30 A, 120/208V WYE, 9 IEC C-13 and 3 IEC C-19 and 6 NEMA 5-20R receptacles, RJ-45 Ethernet port with red LED current monitor, three 20 A double pole magnetic breaker/on-off switch with integral switch guard, and 10' power cord with NEMA L21-30P twist lock plug. UL and c-UL Listed. Dimensions: 33.0"H x 2.0"W x 2.0"D Breaker Doghouse add 1.44" (87.4mm) to overall depth (838mm x 51mm x 51mm)	1
Vertical 30 AMP, 3 Phase WYE 208V Networked Circuit/Breaker (XY, YZ, ZX) Monitoring		
QZ1B1P3BN30P1††	Vertical power strip 30 A, 208V, WYE, 24 IEC C-13 and 6 IEC C-19 receptacles, RJ-45 Ethernet port with red LED current monitor, three 20 A double pole magnetic breaker/on-off switch with integral switch guard and 10' power cord with NEMA L21-30P twist lock plug. UL and c-UL Listed. Dimensions: 66.3"H x 2.0"W x 2.0"D Breaker Doghouse add 1.44" (87.4mm) to overall depth (1683mm x 51mm x 51mm)	1
Vertical 30 AMP, 3 Phase WYE 230/400V Networked Phase/Breaker (X, Y, Z) Monitoring		
QZ1D1Q3BN30P1	Vertical power strip 30 A, 230/400V WYE, 24 IEC C-13 and 6 IEC C-19 receptacles, RJ-45 Ethernet port with red LED current monitor three 20 A double pole magnetic breaker/on-off switch with integral switch guard, and 10' power cord with NEMA L22-30P twist lock plug. UL and c-UL Listed. Dimensions: 66.3"H x 2.0"W x 2.0"D Breaker Doghouse add 1.44" (87.4mm) to overall depth (1683mm x 51mm x 51mm)	1
Vertical 60 AMP, 208V Networked Breaker Monitoring		
QZ1B2C3BN30P1	Vertical power strip 60 A, 208V, 24 IEC C-13 and 6 IEC C-19 receptacles, RJ-45 Ethernet port with red LED current monitor, three 20 A double pole magnetic breaker/on-off switch with integral switch guard, and 10' power cord with IEC 60309 – 2P+E pin in sleeve water tight connector. UL and c-UL Listed. Dimensions: 66.3"H x 2.0"W x 2.0"D Breaker Doghouse add 1.44" (87.4mm) to overall depth (1683mm x 51mm x 51mm)	1
Horizontal 60 AMP, 3 Phase Delta 208V Networked Breaker Monitoring		
PZ1B2G6BN12N1	Horizontal power strip 60 A, 208V, Delta, 12 IEC C-19 receptacles, RJ-45 Ethernet port with red LED current monitor, six 20 A double pole magnetic breaker/on-off switch with integral switch guard and 10' power cord with IEC 60309 – 3P+E pin in sleeve connector. UL and c-UL Listed. Dimensions: 3.4"H x 17.0"W x 9.0"D (86mm x 431mm x 229mm)	1
Vertical 60 AMP, 3 Phase Delta 208V Networked Breaker Monitoring		
QZ1B2G6BN24Z1	Vertical power strip 60 A, 208V, Delta, 12 IEC C-13 and 12 IEC C-19 receptacles, RJ-45 Ethernet port with red LED current monitor, six 20 A double pole magnetic breaker/on-off switch with integral switch guard and 10' power cord with IEC 60309 – 3P+E pin in sleeve connector. UL and c-UL Listed. Dimensions: 66.3"H x 2.3"W x 3.5"D (1683mm x 58mm x 89mm)	1
Vertical 80 AMP, 3 Phase Delta 208V Phase (X, Y, Z) and Outlet Monitoring		
QQ1B6A4AP12N1	Vertical power strip 80 A, 208V, Delta, 12 IEC C-19 receptacles, RJ-45 Ethernet port with red LED current monitor, four 20 A triple pole magnetic breaker/on-off switch with integral switch guard, and hardwired – wiring access panel conduit connection. UL and c-UL Listed. Dimensions: 66.3"H x 3.5"W x 3.5"D (1683mm x 89mm x 89mm)	1

††For Delta, replace "P" with "N", i.e. QZ1B1N3BN30P1.

**QZ1B2G6BN24Z1**

Networked Power Outlet Units (continued)

60 AMP Networked Monitoring for Nexus

Part Number	Part Description	Std. Pkg. Qty.
Vertical 60 AMP, 3 Phase Delta 208 Networked Breaker Monitoring for Nexus 7.5kW Power Supplies		
 QZ1B2G6BN06L1	QZ1B2G6BN06L1 Vertical power strip with a 60 A, 208V, Delta, 6 NEMA L6-30R receptacles RJ-45 Ethernet port with red LED current monitor, six 30 A double pole magnetic breaker/on-off switch with integral switch guard, and 10' power cord with IEC 60309 – 3P+E pin in sleeve connector. UL and c-UL Listed. Dimensions: 66.3"H x 2.25"W x 3.4"D (1683mm x 57mm x 87mm)	1
 PZ1B2G3BN03L1	PZ1B2G3BN03L1 Horizontal power strip with a 60 A, 208V, Delta, 3 NEMA L6-30R receptacles RJ-45 Ethernet port with red LED current monitor, three 30 A double pole magnetic breaker/on-off switch with integral switch guard, and 10' power cord with IEC 60309 – 3P+E pin in sleeve connector. UL and c-UL Listed. Dimensions: 3.4"H x 17.0"W x 9.0"D (86mm x 431mm x 229mm)	1
 QZ1B2G3BN03L1	QZ1B2G3BN03L1 Vertical power strip with a 60 A, 208V, Delta, 3 NEMA L6-30R receptacles RJ-45 Ethernet port with red LED current monitor, three 30 A double pole magnetic breaker/on-off switch with integral switch guard, and 10' power cord with IEC 60309 – 3P+E pin in sleeve connector. UL and c-UL Listed. Dimensions: 30.0"H x 2.25"W x 3.44"D (762mm x 57mm x 87mm)	1
 QZ1B2G5BN2271	QZ1B2G5BN2271 Vertical power strip with a 60 A, 208V, Delta, 16 IEC C-13, 4 IEC C-19 and 2 NEMA L6-30R receptacles RJ-45 Ethernet port with red LED current monitor, one 30 A and four 20 A double pole magnetic breaker/on-off switch with integral switch guard, and 10' power cord with IEC 60309 – 3P+E pin in sleeve connector. UL and c-UL Listed. Dimensions: 66.3"H x 2.25"W x 3.4"D (1683mm x 57mm x 87mm)	1
Vertical 16 AMP, 230V Networked Aggregate Monitoring		
 QZ1D2A0BA30P1	QZ1D2A0BA30P1 Vertical power strip 16 A, 230V, 24 IEC C-13 and 6 IEC C-19 receptacles, RJ-45 Ethernet port with red LED current monitor with a IEC 60309 – 2P+ E pin in sleeve connector. Complies with IEC 60950-1, EN 55022, EN 55024 and CE Marked. Dimensions: 66.3"H x 2.0"W x 2.0"D (1683mm x 51mm x 51mm)	1
Vertical 16 AMP, 3 Phase WYE 230/400V Networked Circuit Phase (X, Y, Z) Monitoring		
 QZ1B2G5BN2271	QZ1D2Q0BA30P1 Vertical power strip 16 A, 230/400V, WYE, 24 IEC C-13 and 6 IEC C-19 receptacles, RJ-45 Ethernet port with red LED current monitor and 10' power cord with IEC 60309 3P+N+ E pin in sleeve connector. Complies with IEC 60950-1, EN 55022, EN 55024 and CE Marked. Dimensions: 66.3"H x 2.0"W x 2.0"D (1683mm x 51mm x 51mm)	1
Vertical 32 AMP, 230V Networked Aggregate/Breaker Monitoring		
 QZ1D2B2BM30P1	QZ1D2B2BM30P1 Vertical power strip 32 A, 230V, 24 IEC C-13 and 6 IEC C-19 receptacles, RJ-45 Ethernet port with red LED current monitor, two 16 A single pole magnetic breaker/on-off switch with integral switch guard with a IEC 60309 – 2P+E pin in sleeve connector. Complies with IEC 60950-1, EN 55022, EN 55024 and CE Marked. Dimensions: 66.3"H x 2.0"W x 2.0"D Breaker Doghouse add 1.44" (87.4mm) to overall depth (1683mm x 51mm x 51mm)	1
Vertical 32 AMP, 3 Phase WYE 230/400V Networked Circuit Phase (X, Y, Z) Monitoring		
 QZ1D2P3BN30P1	QZ1D2P3BN30P1 Vertical power strip 32 A, 230/400V, WYE, 24 IEC C-13 and 6 IEC C-19 receptacles, RJ-45 Ethernet port with red LED current monitor, three 16 A single pole magnetic breaker/on-off switch with integral switch guard and 10' power cord with IEC 60309 3P+ N+E, pin in sleeve connector. Complies with IEC 60950-1, EN 55022, EN 55024 and CE Marked. Dimensions: 66.3"H x 2.0"W x 2.0"D Breaker Doghouse add 1.44" (87.4mm) to overall depth (1683mm x 51mm x 51mm)	1



PN1A1C0BA10E1

Networked and Environmental Power Outlet Units

- Remote access to power consumption data via a web-based GUI provides global network access to real-time power information
- Environmental monitoring measures in-cabinet temperature
- Integrates with Panduit[®] PIM[™] Software which aggregates power information through a single web interface
- Provides user-defined alarm/messaging capabilities for specific events that exceed thresholds
- Integrated 2 line x 8 character LED display
- Optional remote LED display available for local monitoring, part number PVQ-RD

Part Number	Part Description	Std. Pkg. Qty.
Horizontal 15 AMP, 120V Networked and Environmental Aggregate Monitoring		
PN1A1B0BA10B1	Horizontal power strip 15 A, 120V, 10 NEMA 5-15R receptacles, with LED current monitor, RJ-45 Ethernet port with two RJ12 remote environmental ports, remote display port, and 10' power cord with NEMA 5-15P plug. UL and c-UL Listed. Dimensions: 1.73"H x 17.0"W x 6.5"D (44mm x 432mm x 165mm)	1
Horizontal 20 Amp, 230V Networked and Environmental Aggregate Monitoring		
PN1A1C0BA10E1	Horizontal power strip 20 A, 120V, 10 NEMA 5-20R receptacles, with LED current monitor, RJ-45 Ethernet port with two RJ12 remote environmental ports, remote display port, and 10' power cord with NEMA 5-20P plug. UL and c-UL Listed. Dimensions: 1.73"H x 17.0"W x 6.5"D (44mm x 432mm x 165mm)	1
PN1A1D0BA10E1	Horizontal power strip 20 A, 120V, 10 NEMA 5-20R receptacles, with red LED current monitor, RJ-45 Ethernet port with two RJ12 remote environmental ports, remote display port, and 10' power cord with NEMA L5-20P plug. UL and c-UL Listed. Dimensions: 1.73"H x 17.0"W x 6.5"D (44mm x 432mm x 165mm)	1
PN1A1D0BA12M1	Horizontal power strip 20 A, 120V, 12 IEC C-13 receptacles, with red LED current monitor, RJ-45 Ethernet port with two RJ12 remote environmental ports, remote display port, and 10' power cord with NEMA L5-20P plug. UL and c-UL Listed. Dimensions: 1.73"H x 17.0"W x 6.5"D (44mm x 432mm x 165mm)	1
Vertical 20 AMP, 120V Networked and Environmental Aggregate Monitoring		
QN1A1C0BA24E1	Vertical power strip 20 A, 120V, 24 NEMA 5-20R receptacles, with red LED current monitor, RJ-45 Ethernet port with two RJ12 remote environmental ports, remote display port, and 10' power cord with NEMA 5-20P plug. UL and c-UL Listed. Dimensions: 66.3"H x 2.0"W x 2.0"D (1683mm x 51mm x 51mm)	1
Vertical 20 AMP, 3 Phase WYE 120V Networked and Environmental Phase (X, Y, Z) Monitoring		
QN1A1J0BA24E1	Vertical power strip 20 A, 120V, WYE, 24 NEMA 5-20R receptacles, with red LED current monitor, RJ-45 Ethernet port with two RJ12 remote environmental ports, remote display port, and 10' power cord with NEMA L21-20P twist lock plug. UL and c-UL Listed. Dimensions: 66.3"H x 2.0"W x 2.0"D (1683mm x 51mm x 51mm)	1
Vertical 20 AMP, 3 Phase WYE 208V Networked and Environmental Circuit (X, Y, Z) Monitoring		
QN1B1J0BA30P1	Vertical power strip 20 A, 208V, WYE, 24 IEC C-13 and 6 IEC C-19 receptacles RJ-45 Ethernet port with two RJ12 remote environmental display ports, remote display port, and 10' power cord with NEMA L21-20P twist lock plug. UL and c-UL Listed. Dimensions: 66.3"H x 2.0"W x 2.0"D (1683mm x 51mm x 51mm)	1

Networked and Environmental Power Outlet Units (continued)

Part Number	Part Description	Std. Pkg. Qty.
Vertical 30 AMP, 120V Networked and Environmental Circuit Breaker Level Monitoring		
QN1A1M2BM24E1	Vertical power strip 30 A, 120V, 24 NEMA 5-20R receptacles, with red LED current monitor, RJ-45 Ethernet port with two RJ12 remote environmental ports, remote display port, two 20 A single pole magnetic breaker/on-off switch with integral switch guard, and 10' power cord with NEMA L5-30P twist lock plug. UL and c-UL Listed. Dimensions: 66.3"H x 2.0"W x 2.0"D Breaker Doghouse add 1.44" (87.4) to overall depth (1683mm x 51mm x 51mm)	1
Vertical 30 AMP, 208V Networked and Environmental Circuit Breaker Monitoring		
QN1B1L2BN30P1	Vertical power strip 30 A, 208V, 24 IEC C-13 and 6 IEC C-19 receptacles, with red LED current monitor, RJ-45 Ethernet port with two RJ12 remote environmental ports, remote display port, two 20 A double pole magnetic breaker/on-off switch with integral switch guard, and 10' power cord with NEMA L6-30P twist lock plug. UL and c-UL Listed. Dimensions: 66.3"H x 2.0"W x 2.0"D Breaker Doghouse add 1.44" (87.4) to overall depth (1683mm x 51mm x 51mm)	1
QN1B1L2BN24H1	Vertical power strip 30 A, 208V, 24 NEMA 6-20R receptacles, with red LED current monitor, RJ-45 Ethernet port with two RJ12 remote environmental ports, remote display port, two 20 A double pole magnetic breaker/on-off switch with integral switch guard, and 10' power cord with NEMA L6-30P twist lock plug. UL and c-UL Listed. Dimensions: 66.3"H x 2.0"W x 2.0"D Breaker Doghouse add 1.44" (87.4) to overall depth (1683mm x 51mm x 51mm)	1
Half Height Vertical 30 Amp, 208V Networked and Environmental Circuit Breaker Monitoring		
QN1B1L2BN0861	Vertical power strip 30 A, 208V, 6 IEC C-13 and 2 IEC C-19 receptacles, with red LED current monitor, RJ-45 Ethernet port with two RJ12 remote environmental ports, remote display port, two 20 A double pole magnetic breaker/on-off switch with integral switch guard, and 10' power cord with NEMA L6-30P twist lock plug. UL and c-UL Listed. Dimensions: 33.0"H x 2.0"W x 2.25"D Breaker Doghouse add 1.44" (87.4) to overall depth (838mm x 51mm x 57mm)	1
Half height Vertical 30 AMP, 208V Networked and Environmental Secondary with Uplink Port, Circuit Breaker Monitoring		
QD0B1L2BN0861	Vertical power strip 30 A, 208V, 6 IEC C-13 and 2 IEC C-19 receptacles, RJ-45 Ethernet port with two RJ12 remote environmental ports, one uplink port to daisy chain units together, two 20 A double pole magnetic breaker/on-off switch with integral switch guard, and 10' power cord with NEMA L6-30P twist lock plug. UL and c-UL Listed. Dimensions: 33.0"H x 2.0"W x 2.25"D Breaker Doghouse add 1.44" (87.4mm) to overall depth (838mm x 51mm x 57mm)	1
Vertical 30 AMP, 3 Phase WYE 120V Networked and Environmental Phase/Breaker (X, Y, Z) Monitoring		
QN1A1P3BN30P1	Vertical power strip 30 A, 120V, WYE, 24 IEC C-13 and 6 IEC C-19 receptacles with red LED current monitor, RJ-45 Ethernet port with two RJ12 remote environmental ports and remote display port, three 20 A double pole magnetic breaker/on-off switch with integral switch guard, and 10' power cord with NEMA L21-30P twist lock plug. UL and c-UL Listed. Dimensions: 66.3"H x 2.0"W x 2.0"D Breaker Doghouse add 1.44" (87.4) to overall depth (1683mm x 51mm x 51mm)	1
QN1A1P3BN24E1	Vertical power strip 30 A, 120 V, WYE, 24 NEMA 5-20R receptacles, with red LED current monitor, RJ-45 Ethernet port with two RJ12 remote environmental ports and remote display port, three 20 A double pole magnetic breaker/on-off switch with integral switch guard, and 10' power cord with NEMA L21-30P twist lock plug. UL and c-UL Listed. Dimensions: 66.3"H x 2.0"W x 2.0"D Breaker Doghouse add 1.44" (87.4mm) to overall depth (1683mm x 51mm x 51mm)	1



QN1B1L2BN0861

Table continues on page L.52

Networked and Environmental Power Outlet Units (continued)**QN1B1P3BN30P1****QN1D2A0BA30P1**

Part Number	Part Description	Std. Pkg. Qty.
Vertical 30 AMP, 3 Phase WYE 208V Networked and Environmental Phase/Breaker (X, Y, Z) Monitoring		
QN1B1P3BN30P1	Vertical power strip 30 A, 208V, WYE, 24 IEC C-13 and 6 IEC C-19 receptacles, with red LED current monitor, RJ-45 Ethernet port with two RJ12 remote environmental ports and remote display port, three 20 A double pole magnetic breaker on-off switch with integral switch guard, and 10' power cord with NEMA L21-30P twist lock plug. UL and c-UL Listed. Dimensions: 66.3"H x 2.0"W x 2.0"D Breaker Doghouse add 1.44" (87.4mm) to overall depth (1683mm x 51mm x 51mm)	1
QN1B1P3BN24H1	Vertical power strip 30 A, 208 V, WYE, 24 NEMA 6-20R receptacles, RJ-45 Ethernet port with two RJ12 remote environmental ports, three 20 A double pole magnetic breaker/on-off switch with integral switch guard, and 10' power cord with NEMA L21-30P twist lock plug. UL and c-UL Listed. Dimensions: 66.3"H x 2.0"W x 2.0"D Breaker Doghouse add 1.44" (87.4mm) to overall depth (1683mm x 51mm x 51mm)	1
Vertical 60 Amp, 3 Phase WYE 208V Networked and Environmental Phase Monitoring (X, Y, Z)		
QN1B2G6BN24R1	Vertical switched power strip 60 A, 208V, Delta, 18 IEC C-13 and 6 IEC C-19 receptacles, RJ-45 Ethernet port with two RJ12 remote environmental ports, red LED current monitor and remote display port, six 20 A double pole magnetic breaker/on-off switch with integral switch guard, and 10' power cord with IEC 60309 – 3P+E plug. UL and c-UL Listed. Dimensions: 66.3"H x 2.3"W x 3.4"D (1683mm x 58mm x 87mm)	1
Vertical 16 AMP, 230V Networked and Environmental Aggregate Monitoring		
QN1D2A0BA30P1	Vertical power strip 16 A, 230V, 24 IEC C-13 and 6 IEC C-19 receptacles, with LED current monitor, RJ-45 Ethernet port with two RJ12 remote environmental ports, and remote display port, and 3m power cord with IEC 60309 – 2P+E, pin in sleeve connector. Complies with IEC 60950-1, EN 55022, EN 55024 and CE Marked. Dimensions: 66.3"H x 2.0"W x 2.3"D (1683mm x 51mm x 58mm)	1
Vertical 16 AMP, 3 Phase WYE 230/400V Networked and Environmental Phase Monitoring (X, Y, Z)		
QN1D2Q0BA30P1	Vertical power strip 16 A, 230/400V, WYE, 24 IEC C-13 and 6 IEC C-19 receptacles, with red LED current monitor, RJ-45 Ethernet port with two RJ12 remote environmental ports, and remote display port, and 3m power cord with IEC 60309 – 3P+ N+ E, pin in sleeve connector. Complies with IEC 60950-1, EN 55022, EN 55024 and CE Marked. Dimensions: 66.3"H x 2.0"W x 2.3"D (1683mm x 51mm x 58mm)	1
Vertical 32 AMP, 230V Networked and Environmental Breaker Monitoring		
QN1D2B2BN30P1	Vertical power strip 32 A, 230V, 24 IEC C-13 and 6 IEC C-19 receptacles, with LED current monitor, RJ-45 Ethernet port with two RJ12 remote environmental ports, two and remote display port, two 16 A double pole magnetic breaker/on-off switch with integral switch guard, and 3m power cord with IEC 60309 – 2P+E pin in sleeve connector. Complies with IEC 60950-1, EN 55022, EN 55024 and CE Marked. Dimensions: 66.3"H x 2.0"W x 2.3"D Breaker Doghouse add 1.44" (87.4mm) to overall depth (1683mm x 51mm x 58mm)	1
Vertical 32 AMP, 3 Phase WYE 230/400V Networked and Environmental (X, Y, Z) Monitoring		
QN1D2P3BN30P1	Vertical power strip 32 A, 230/400V, WYE, 24 IEC C-13 and 6 IEC C-19 receptacles, with LED current monitor, RJ-45 Ethernet port with two RJ12 remote environmental ports, and remote display port, three 16 A double pole magnetic breaker/on-off switch with integral switch guard, and 3m power cord with IEC 60309 – 3P+N+E, pin in sleeve connector. Complies with IEC 60950-1, EN 55022, EN 55024 and CE Marked. Dimensions: 66.3"H x 2.0"W x 2.3"D Breaker Doghouse add 1.44" (87.4mm) to overall depth (1683mm x 51mm x 58mm)	1

Switched with Per Outlet Monitoring Power Outlet Units

- Remote switching capability for power cycling individual outlets or a group of outlets on or off to reboot equipment or power off individual outlets to stop unauthorized use
- Per outlet monitoring provides data to determine if power allocations are accurate and the efficiency metric of any server in the data center allowing individual servers to be identified as candidates for additional capacity, redeployment, or decommissioning
- Time delay sequencing avoids circuit overload due to high in-rush current at equipment start up
- Remote access to power consumption data via a web-based GUI provides global network access to real-time power information
- Locking receptacles support and retain any standard IEC power cords preventing unintentional power loss
- Integrates with Panduit® PIM™ Software which aggregates power information through a single web based GUI
- Measure in-cabinet temperature, humidity, airflow, and dew point remotely to prevent environmental factors that can cause equipment to overheat or malfunction
- Alarm messaging capability provides user-defined alarm/messaging capabilities for specific events that exceeded thresholds
- Each outlet has a green LED for indication if the outlet is on or off for easy visual identification
- Optional remote LED display available for local monitoring, part number PVQ-RD
- Integrated 2 line x 8 character LED display



Part Number	Part Description	Std. Pkg. Qty.
Vertical 20 AMP, 208V Switched with Per Outlet Power and Environmental Monitoring		
QL1B1F0BA2401*	Vertical switched power strip with per outlet power and environmental monitoring, 20 A, 208V, WYE, 21 IEC C-13 and 3 IEC C-19 locking receptacles RJ-45 Ethernet port with two RJ12 remote environmental ports, and 10' power cord with NEMA L21-20P twist lock plug. UL and c-UL Listed. Dimensions: 66.3"H x 2.5"W x 2.3"D (1683mm x 64mm x 57mm)	1
Vertical 20 AMP, 3 Phase WYE 230/400V Switched with Per Outlet Power and Environmental Monitoring		
QL1D1K0BA2401*	Vertical switched power strip 20 A, 230/400V, WYE, 21 IEC C-13 and 3 IEC C-19 locking receptacles RJ-45 Ethernet port with two RJ12 remote environmental ports, and 10' power cord with NEMA L22-20P twist lock plug. UL and c-UL Listed. Dimensions: 66.3"H x 2.5"W x 2.3"D (1683mm x 64mm x 57mm)	1
Vertical 20 AMP, 3 Phase WYE 208V Switched with Per Outlet Power and Environmental Monitoring		
QL1B1J0BA2401*	Vertical switched power strip with per outlet power and environmental monitoring, 20 A, 208V, WYE, 21 IEC C-13 and 3 IEC C-19 locking receptacles RJ-45 Ethernet port with two RJ12 remote environmental ports, and 10' power cord with NEMA L21-20P twist lock plug. UL and c-UL Listed. Dimensions: 66.3"H x 2.5"W x 2.3"D (1683mm x 64mm x 57mm)	1
Vertical 30 AMP, 208V Switched with Per Outlet Power and Environmental Monitoring		
QL1B1L2BN24AA1*	Vertical switched power strip with per outlet power and environmental monitoring, 30 A, 208V, 20 IEC C-13 and 4 IEC C-19 locking receptacles, RJ-45 Ethernet port with two RJ12 remote environmental ports, two 20 A double pole magnetic breaker/on-off switch with integral switch guard, and 10' power cord with NEMA L6-30P twist lock plug. UL and c-UL Listed. Dimensions: 70.00"H x 2.5"W x 2.3"D Breaker Doghouse add 1.44" (87.4mm) to overall depth (1778mm x 64mm x 57mm)	1

*For aggregate, phase, or breaker only monitoring, replace "QL" with "QS", i.e. QS1B1F0BA2401.

Table continues on page L.55

Switched with per Outlet Monitoring Power Outlet Units (continued)

Part Number	Part Description	Std. Pkg. Qty.
Vertical 30 AMP, 3 Phase WYE 208V Switched with Per Outlet Power and Environmental Monitoring		
QL1B1P3BN2491*	Vertical switched power strip with per outlet power and environmental monitoring, 30 A, 208V, WYE, 18 IEC C-13 and 6 IEC C-19 locking receptacles, RJ-45 Ethernet port with two RJ12 remote environmental ports, three 20 A double pole magnetic breaker/on-off switch with integral switch guard, and 10' power cord with NEMA L21-30P twist lock plug. UL and c-UL Listed. Dimensions: 72.0"H x 2.5"W x 2.3"D Breaker Doghouse add 1.44" (87.4mm) to overall depth (1829mm x 64mm x 57mm)	1
QL1B1N3BN2401*	Vertical switched power strip with per outlet power and environmental monitoring, 30 A, 208V, Delta, 21 IEC C-13 and 3 IEC C-19 locking receptacles, RJ-45 Ethernet port with two RJ12 remote environmental ports, three 20 A double pole magnetic breaker/on-off switch with integral switch guard, and 10' power cord with NEMA 15-30P twist lock plug. UL and c-UL Listed. Dimensions: 72.0"H x 2.5"W x 2.3"D Breaker Doghouse add 1.44" (87.4mm) to overall depth (1829mm x 64mm x 57mm)	1
Vertical 30 AMP, 3 Phase WYE 230/400V Switched with Per Outlet Power and Environmental Monitoring		
QL1D1Q3BN2401*	Vertical power strip 30 A, 230/400V, WYE, 21 IEC C-13 and 3 IEC C-19 locking receptacles, RJ-45 Ethernet port with two RJ12 remote environmental ports, three 20 A double pole magnetic breaker/on-off switch with integral switch guard, and 10' power cord with NEMA L22-30P twist lock plug. UL and c-UL Listed. Dimensions: 72.0"H x 2.5"W x 2.3"D Breaker Doghouse add 1.44" (87.4mm) to overall depth (1829mm x 64mm x 57mm)	1
Vertical 60 AMP, 3 Phase Delta 208V Switched with Per Outlet Power and Environmental Monitoring		
QL1B2G6BN2491	Vertical switched power strip with per outlet power and environmental monitoring, 60 A, 208V, Delta, 18 IEC C-13 and 6 IEC C-19 locking receptacles, red LED current monitor, RJ-45 Ethernet port with two RJ12 remote environmental ports, six 20 A double pole magnetic breaker/on-off switch with integral switch guard, and 10' power cord with IEC 60309 – 3P+E plug. UL and c-UL Listed. Dimensions: 66.0"H x 4.0"W x 3.4"D (1683mm x 102mm x 87mm)	1

*For aggregate, phase, or breaker only monitoring, replace "QL" with "QS", i.e. QS1B1F0BA2401.

Switched with per Outlet Monitoring Power Outlet Units (continued)

Part Number	Part Description	Std. Pkg. Qty.
Vertical 16 AMP, 230V Switched with Per Outlet Power and Environmental Monitoring		
QL1D2A0BA2401*	Vertical switched power strip with per outlet power and environmental monitoring 16 A, 230V, 21 IEC C-13 and 3 IEC C-19 locking receptacles, RJ-45 Ethernet port with two RJ12 remote environmental ports, and 3m power cord with IEC 60309 – 2P+E pin in sleeve connector. Complies with IEC 60950-1, EN 55022, EN 55024, and CE Marked. Dimensions: 66.3"H x 2.5"W x 2.3"D (1683mm x 64mm x 57mm)	1
Vertical 16 AMP, 3 Phase WYE 230/400V Switched with Per Outlet Power and Environmental Monitoring		
QL1D2Q0BA2401	Vertical switched power strip with per outlet power and environmental monitoring, 16 A, 230/400V, WYE, 21 IEC C-13 and 3 IEC C-19 locking receptacles, red LED current monitor, RJ-45 Ethernet port with two RJ12 remote environmental ports, and 3mm power cord with IEC 60309 – 3P+ N+ E, pin in sleeve connector. Complies with IEC 60950-1, EN 55022, EN 55024 and CE Marked. Dimensions: 66.3"H x 2.5"W x 2.3"D (1683mm x 64mm x 57mm)	1
Vertical 32 AMP, 230V Switched with Per Outlet Power and Environmental Monitoring		
QL1D2B2BN24AA1*	Vertical power strip 32 A, 230V, 20 IEC C-13 and 4 IEC C-19 locking receptacles, RJ-45 Ethernet port with two RJ12 remote environmental ports, two 16 A double pole magnetic breaker/on-off switch with integral switch guard, and 3m power cord with IEC 60309 – 2P+E pin in sleeve connector. Complies with IEC 60950-1, EN 55022, EN 55024 and CE Marked. Dimensions: 66.3"H x 2.0"W x 2.25"D Breaker Doghouse add 1.44" (87.4mm) to overall depth (1683mm x 51mm x 58mm)	1
Vertical 32 AMP, 3 Phase WYE 230/400 Switched with Per Outlet Power and Environmental Monitoring		
QL1D2P3BN2401*	Vertical power strip 32 A, 230/400V, WYE, 21 IEC C-13 and 3 IEC C-19 locking receptacles, RJ-45 Ethernet port with two RJ12 remote environmental ports, three 16 A double pole magnetic breaker/on-off switch with integral switch guard, and 3m power cord with IEC 60309 – 3P+N+E pin in sleeve connector. Complies with IEC 60950-1, EN 55022, EN 55024 and CE Marked. Dimensions: 66.3"H x 2.0"W x 2.25"D Breaker Doghouse add 1.44" (87.4mm) to overall depth (1683mm x 51mm x 58mm)	1

*For aggregate, phase, or breaker only monitoring, replace "QL" with "QS", i.e. QS1B1F0BA2401.

Environmental Sensors

Designed specifically for the QN, QS, QL, and PL series power outlet units. The sensors provide temperature, humidity, and airflow information. The remote display allows for local monitoring via a LED display.



PVQ-RD



PVQ-EST18



PVQ-ESDP



PVQ-ESW

Part Number	Part Description	Std. Pkg. Qty.
PVQ-RD	Remote Display Monitor, RJ-11 connection cord, mounting bracket, adhesive pads, and hardware.	1
PVQ-EST-18	Environmental temperature sensor with 18' cord, includes: 15 (19") adhesive cord clips, 15 (.38") adhesive cord clips, 10 push mount ties, .29" cable clamp and hardware.	1
PVQ-ESTAFHD-18	Temperature, humidity, airflow, and dew point sensor with 18' cord. Includes: 15 (19") adhesive cord clips, 10 (.38") adhesive cord clips, 15 push mount ties, 2 (.29") cable clamp and hardware.	1
PVQ-ESDP-NS	PViQ™ Environmental Door Position Sensor with 30' cord, includes: 2 doors sensors, brackets, 15 (19") adhesive cord clips, 10 (.38") adhesive cord clips, 15 push mount ties, 2 (.29") cable clamp and hardware.	1
PVQ-ESDP-NA	PViQ™ Environmental Door Position Sensor with 30' cord, includes: 2 doors sensors, brackets, 15 (19") adhesive cord clips, 10 (.38") adhesive cord clips, 15 push mount ties, 2 (.29") cable clamp and hardware.	1
PVQ-ESDP	PViQ™ Environmental Door Position Sensor with 30' cord.	1
PVQ-ESW	PViQ™ Environmental Water Sensor with 20' cord.	1

Power Cords

- Power Cords are of optimal lengths between POUs and active equipment to minimize excess lengths and cord slack

- Improve cable management and increase air circulation for better thermal performance.
- A variety of configurations available for multiple application environments



PC14C13BL1.5

Part Number	Length		Color	Std. Pkg. Qty.
	Ft.	mm		
IEC 320 C14 to IEC 320 C13				
PC14C13BL1.5	1.5	460.0	Black	1
PC14C13BL2	2.0	610.0	Black	1
PC14C13BL3	3.3	1000.0	Black	1
PC14C13BL4	4.0	1220.0	Black	1
PC14C13BL5	5.0	1500.0	Black	1
PC14C13BL6.5	6.5	2000.0	Black	1
PC14C13BL7	7.0	2134.0	Black	1
PC14C13BL8	8.0	2500.0	Black	1
PC14C13BL9	9.0	2740.0	Black	1
PC14C13BL10	10.0	3050.0	Black	1
PC14C13GY1.5	1.5	460.0	Gray	1
PC14C13GY2	2.0	610.0	Gray	1
PC14C13GY3	3.3	1000.0	Gray	1
PC14C13GY4	4.0	1220.0	Gray	1
PC14C13GY5	5.0	1500.0	Gray	1
PC14C13GY6.5	6.5	2000.0	Gray	1
PC14C13GY7	7.0	2134.0	Gray	1
PC14C13GY8	8.0	2500.0	Gray	1
PC14C13GY9	9.0	2740.0	Gray	1
PC14C13GY10	10.0	3050.0	Gray	1
IEC 320 C20 to IEC 320 C13				
PC20C13BL1.5	1.5	460.0	Black	1
PC20C13BL3	3.3	1000.0	Black	1
PC20C13BL6	6.0	1830.0	Black	1
IEC 320 C20 to IEC 320 C19				
PC20C19BL3	3.3	1000.0	Black	1
PC20C19BL4	4.0	1220.0	Black	1
PC20C19BL5	5.0	1500.0	Black	1
PC20C19BL6	6.0	1830.0	Black	1
PC20C19GY3	3.3	1000.0	Gray	1
PC20C19GY4	4.0	1220.0	Gray	1
PC20C19GY5	5.0	1500.0	Gray	1
PC20C19GY6	6.0	1830.0	Gray	1

Table continues on page L.58

Power Cords (continued)

Part Number	Length		Color	Std. Pkg. Qty.
	Ft.	mm		
NEMA 5-15 to IEC 320 C13				
P515C13BL1.5	1.5	460.0	Black	1
P515C13BL3	3.0	950.0	Black	1
P515C13BL6	6.0	1830.0	Black	1
P515C13BL7	7.0	2134.0	Black	1
P515C13GY3	3.0	950.0	Gray	1
P515C13GY6	6.0	1830.0	Gray	1
NEMA 5-15 to IEC 320 C19				
P515C19BL1.5	1.5	460.0	Black	1
P515C19BL3	3.0	950.0	Black	1
P515C19BL6	6.0	1830.0	Black	1
NEMA 5-20 to IEC 320 C19				
P520C19BL1.5	1.5	460.0	Black	1
P520C19BL3	3.0	950.0	Black	1
P520C19BL6	6.0	1830.0	Black	1
NEMA 6-20 to IEC 320 C19				
P620C19BL1.5	1.5	460.0	Black	1
P620C19BL3	3.0	950.0	Black	1
P620C19BL6	6.0	1830.0	Black	1

Power Cord Retainers

- Eliminate accidental plug disconnection from power outlet units providing secure connections; reducing the risk of equipment downtime
- Suitable for Panduit power cords and Panduit power outlet units



Part Number	Part Description	Std. Pkg. Qty.
PRPC13W-2.0-X	C13 retaining clip for power outlet units with 2.00 inch chassis.	10
PRPC13W-2.25-X	C13 retaining clip for power outlet units with 2.25 inch chassis.	10
PRPC19Y-2.0-X	C19 retaining clip for power outlet units with 2.00 inch chassis.	10
PRPC19Y-2.25-X	C19 retaining clip for power outlet units with 2.25 inch chassis.	10

4 Post Rack System Roadmap

- Supports deep networking equipment; the rack combines the stability of a cabinet with the accessibility of an open rack to provide maximum flexibility

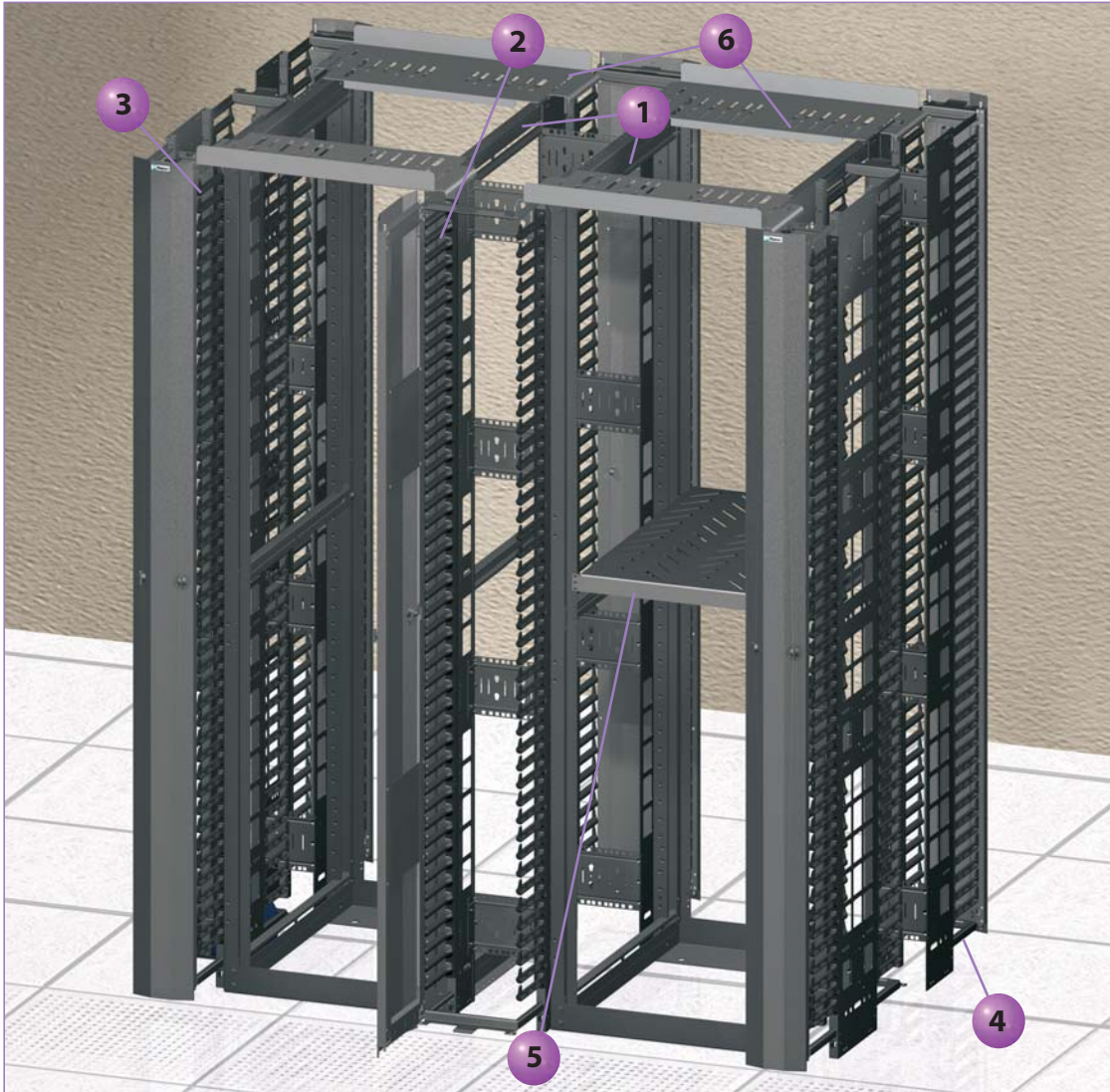

- 1** R4P – 4 Post Rack
84"H x 23.3"W x 30.0"D (45RU)
R4P23 – 4 Post Rack
84"H x 23.3"W x 23.0"D
45 RU (not shown)
R4P36 – 4 Post Rack
84"H x 23.3"W x 36.0"D
45 RU (not shown)
R4P42 – 4 Post Rack
84"H x 23.3"W x 41.5"D
45 RU (not shown)
(page L.60)

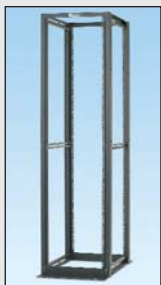

- 2** PatchRunner™ High Capacity
Vertical Managers Available
in 6", 8", 10", 12" widths to
fit 7' racks
(page L.65 – L.68)



- 5** RSHLF – 4 Post Rack Shelf
19"H x 30"W
RSHLF23 – 4 Post Rack Shelf
19"H x 23"W
RSHLF36 – 4 Post Rack Shelf
19"H x 36"W
(page L.61)



- 6** R4PWF – Top Trough with
waterfall creates pathway
above rack 26.1"W x 8.5"D
(page L.61)

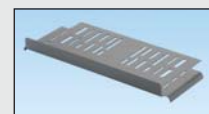

4 Post Racks available in cage nut versions.

4 Post Cable Management Rack System and Accessories

- Independent adjustable front and rear mounting rails can be adjusted while the rack is secured to the floor
- Printed rack space identification on all equipment rails allows for quick location of rack spaces, speeding installation of rack mount items (shipped numbers up per TIA606 specifications; can be set to number down by flipping the rails)
- Rack is UL listed for 2,500 lbs. load rating
- Rear rail construction provides a clear ventilation path for side ventilated switches
- Multiple mounting holes in top flanges for securing ladder rack
- Weld nut construction eliminates the need for a second wrench increasing speed and ease of assembly
- Multiple mounting locations for vertical power strips on any of the four posts or on the adjustable mounting rails
- PatchRunner™ and NetRunner™ Vertical Cable Managers mount directly to the 4 post rack at any of the four corners to provide a flexible end-to-end cable management solution
- Paint piercing washers included to electrically bond rack for simplified grounding
- For the complete grounding solution, see the StructuredGround™ Kits for Racks selection guide on pages M.12 – M.13

**R4P**

Part Number	Part Description	No. of Rack Spaces [^]	Std. Pkg. Qty.
7' 4 Post Rack Threaded Rail			
R4P23	EIA rack with #12-24 threaded rails. Dimensions: 84.0"H x 23.25"W x 23.0"D (2134mm x 591mm x 584mm).	45	1
R4P‡	4 post EIA rack with #12-24 threaded rails. Dimensions: 84.0"H x 23.25"W x 30.0"D (2134mm x 591mm x 762mm).	45	1
R4P36	4 post EIA rack with #12-24 threaded rails. Dimensions: 84.0"H x 23.25"W x 36.0"D (2134mm x 591mm x 914mm).	45	1
R4P42	4 post EIA rack with #12-24 threaded rails. Dimensions: 84.0"H x 23.25"W x 41.5"D (2134mm x 591mm x 1054mm).	45	1
7' 4 Post Rack Cage Nut Rail			
R4P23CN	4 post EIA rack with cage nut rails. Dimensions: 84.0"H x 23.25"W x 23.0"D (2134mm x 591mm x 584mm).	45	1
R4PCN	4 post EIA rack with cage nut rails. Dimensions: 84.0"H x 23.25"W x 30.0"D (2134mm x 591mm x 762mm).	45	1
R4P36CN	4 post EIA rack with cage nut rails. Dimensions: 84.0"H x 23.25"W x 36.0"D (2134mm x 591mm x 914mm).	45	1
R4P42CN	4 post EIA rack with cage nut rails. Dimensions: 84.0"H x 23.25"W x 41.5"D (2134mm x 591mm x 1054mm).	45	1

[^]One rack space = 1.75" (44.45mm).

All product color is black.

‡For 42 RU add suffix 79 to the end of part number and for 42 RU cage nut version add suffix CN79 to the end of the part number.

4 Post Cable Management Rack System and Accessories (continued)



R4P96



R4PAE1



R4PAE2



R4PAE3



R4PWF



RSHLF



RCSTR

Part Number	Part Description	No. of Rack Spaces [^]	Std. Pkg. Qty.
8' 4 Post Rack Threaded Rail			
R4P2396	4 post EIA rack with #12-24 threaded rails. Dimensions: 96.0"H x 23.25"W x 23.0"D (2441mm x 591mm x 584mm).	52	1
R4P96	4 post EIA rack with #12-24 threaded rails. Dimensions: 96.0"H x 23.25"W x 30.0"D (2441mm x 591mm x 762mm).	52	1
R4P3696	4 post EIA rack with #12-24 threaded rails. Dimensions: 96.0"H x 23.25"W x 36.0"D (2441mm x 591mm x 914mm).	52	1
R4P4296	4 post EIA rack with #12-24 threaded rails. Dimensions: 96.0"H x 23.25"W x 41.5"D (2441mm x 591mm x 1054mm).	52	1
8' 4 Post Rack Cage Nut Rail			
R4P23CN96	4 post EIA rack with cage nut rails. Dimensions: 96.0"H x 23.25"W x 23.0"D (2441mm x 591mm x 584mm).	52	1
R4PCN96	4 post EIA rack with cage nut rails. Dimensions: 96.0"H x 23.25"W x 30.0"D (2441mm x 591mm x 762mm).	52	1
R4P36CN96	4 post EIA rack with cage nut rails. Dimensions: 96.0"H x 23.25"W x 36.0"D (2441mm x 591mm x 914mm).	52	1
R4P42CN96	4 post EIA rack with cage nut rails. Dimensions: 96.0"H x 23.25"W x 41.5"D (2441mm x 591mm x 1054mm).	52	1
4 Post Rack Accessories			
R4PAE1	Panduit 4 post rack thermal duct for use with Cisco* 6509, 6509E, 6513, 9513 Director and Juniper 8208 switches.	—	1
R4PAE2	Panduit 4 post rack thermal ducting for use with Cisco* 7018 switch.	—	1
R4PAE3	Panduit 4 post rack thermal ducting for use with Cisco* 7009 switch.	—	1
R4PWF	Top trough with waterfall creates pathway above rack. Dimensions: 1.9"H x 26.1"W x 8.5"D (50mm x 662mm x 216mm).	—	1
RSHLF23	4 post rack mount shelf. Load rating 275 lbs.(124.7 kg). Dimensions: 1.7"H x 19.0"W x 23.0"D (44mm x 483mm x 584mm).	1	1
RSHLF	4 post rack mount shelf. Load rating 275 lbs. (124.7 kg). Dimensions: 1.7"H x 19.0"W x 30.0"D (44mm x 483mm x 762mm).	1	1
RSHLF36	4 post rack mount shelf. Load rating 275 lbs. (124.7 kg). Dimensions: 1.7"H x 19.0"W x 36.0"D (44mm x 483mm x 914mm).	1	1
RCSTR	4 post rack casters.	—	1

[^]One rack space = 1.75" (44.45mm).

All product color is black.

*Cisco is a registered trademark of Cisco Technology Inc.

Table continues on page L.62

4 Post Cable Management Rack System and Accessories (continued)

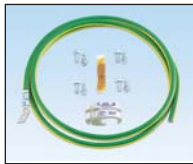

Part Number	Part Description	No. of Rack Spaces [^]	Std. Pkg. Qty.
R4PFP	Adjustable vertical filler panel for Panduit 4 Post Racks blocks by-pass air and directs cold airflow through equipment when used.	45	1
R4PFR	Right vertical finger section for cable management.	11	1
R4PFL	Left vertical finger section for cable management.	11	1
R4PFM	Finger managers for 7 and 8 foot Panduit 4 Post Racks.	—	1
CVPPB	Bracket to vertically mount 1 RU EIA 19" copper and fiber patch panels to the side of the Net-Access™ Cabinet posts or 4 post racks.	—	1
CNSPE	Net-Access™ Network Cabinet and 4 post rack end channel slack spools. Package includes one left and one right slack spool and mounting brackets.	—	1
CVPDUB	Bracket for vertical POU mounting to the side of the Net-Access™ Cabinet posts or 4 post racks (kit of two).	—	1
R4PRT	#12-24 Threaded rails (one pair). 45 RU.	45	1
R4PRCN	Cage nut rails (one pair). 45 RU.	45	1
RFAKIT	Rack anchor kit for concrete floor (set of four).	—	1
S1224-C	#12-24 x .5" mounting screws.	—	100
CNWS1224-C	#12-24 cage nut and screws.	—	100
CNWSM5-C	M5 screw with cage nut.	—	100
CNWSM6-C	M6 screw with cage nut.	—	100
RGCBNJ660P22	#6 AWG (16mm ²) jumper; 60" (1.52m) length; 45° bent lug on grounding strip side; provided with .16 oz. (5cc) of antioxidant, two each #12-24 x 1/2", M6 x 12mm, #10-32 x 1/2" and M5 x 12mm thread-forming screws and a copper compression HTAP* for connecting to the MCBN.	—	1

[^]One rack space = 1.75" (44.45mm).

All product color is black.

‡For 42 RU add suffix 79 to the end of part number and for 42 RU cage nut version add suffix CN79 to the end of the part number.

2 Post Cable Management Rack System and Accessories

- Rack space identification allows quick and easy location of rack mount items
- 3" Rack is UL listed for 1,000 lbs. load rating
- 6" Rack is UL listed for 1,500 lbs. load rating
- Double-sided #12-24 EIA universal mounting hole spacing
- 24 #12-24 mounting screws included
- Can be used with all Panduit cable management and patch panel products in addition to any industry standard 19" components
- Paint piercing washers included to electrically bond rack for simplified grounding; for the complete grounding solution, see the StructuredGround™ Kits for Racks
- 6" rack, R2P6S is compatible with Patchrunner™ and High Capacity PatchRunner™ products only

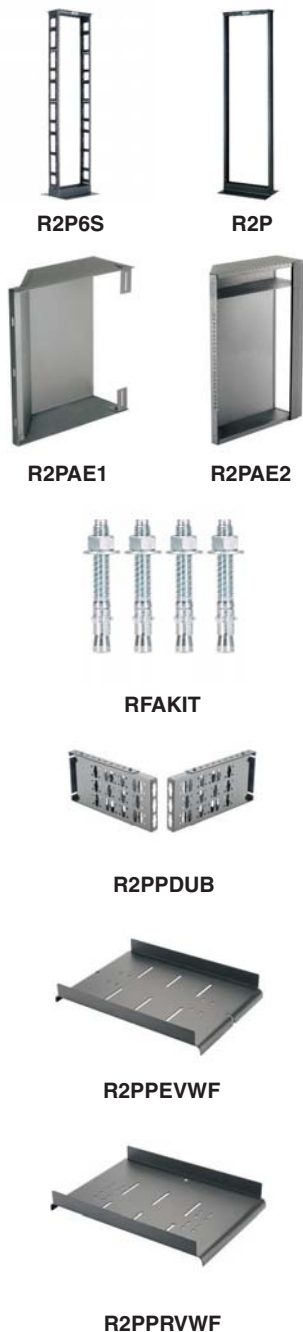

Part Number	Part Description	No. of Rack Spaces [^]	Std. Pkg. Qty.	Std. Ctn. Qty.
6" Channel Rack – Numbered Up				
R2P6S	19" EIA rack, 6" channel, steel. Dimensions: 84.0"H x 20.3"W x 6"D (2134mm x 514mm x 152mm). Note: This rack is compatible with PatchRunner™ and High Capacity PatchRunner™ Vertical Cable Managers only.	45	1	0
R2P6S96	19" EIA rack, 6" channel, steel. Dimensions: 96.0"H x 20.3"W x 6"D (2438mm x 514mm x 152mm). Note: This rack is compatible with PatchRunner™ and High Capacity PatchRunner™ Vertical Cable Managers only.	52	1	0
3" Channel Racks – Numbered Up				
R2P96	19" EIA rack, aluminum. Dimensions: 96.0"H x 20.3"W x 3.0"D (2134mm x 514mm x 76mm).	52	1	0
R2P‡	19" EIA rack, aluminum. Dimensions: 84.0"H x 20.3"W x 3.0"D (2134mm x 514mm x 76mm).	45	1	0
R2P48	19" EIA rack, aluminum. Dimensions: 48.0"H x 20.3"W x 3.0"D (1219mm x 514mm x 76mm).	24	1	0
R2PW	23" EIA rack, aluminum. Dimensions: 84.0"H x 24.3"W x 3.0"D (2134mm x 616mm x 76mm).	45	1	0
2 Post Rack Accessories				
R2PAE1	2 post rack thermal duct for use with Cisco ^{^^} 6509 and 6509E Catalyst switches.	—	1	0
R2PAE2	2 post rack thermal duct for use with Cisco ^{^^} 7009 switch.	—	1	0
RFAKIT	Rack anchor kit for concrete floor (set of four).	—	1	10
S1224-C	#12-24 x .5" mounting screws.	—	100	1000
R2PPDUB	Power Outlet Unit (POU) bracket for 2 and 4 post racks (set of two).	—	1	0
R2PPEVWF	Waterfall Trough for 2 Post Rack and PatchRunner™ High Capacity Vertical Cable Managers.	—	1	0
R2PPRVWF	Waterfall Trough for 2 Post Rack and PatchRunner™ Vertical Cable Managers.	—	1	0

[^]One rack space = 1.75" (44.45mm).
 All product color is black.
^{^^}Cisco is a registered trademark of Cisco Technology, Inc.
[‡]For 42 RU add suffix 79 to the end of part number.

Table continues on page L.64



2 Post Cable Management Rack System and Accessories (continued)



Part Number	Part Description	No. of Rack Spaces [^]	Std. Pkg. Qty.	Std. Ctn. Qty.
2 Post 3" Channel Racks Numbered Up with Dual-Sided Vertical Cable Managers				
RWMPV45E	#12-24 threaded equipment mounting rails with front and rear manager. Dimensions: 84.0"H x 25.5"W x 15"D (2134mm x 648mm x 381mm)	45	1	0
RWMPVHC45E	#12-24 threaded equipment mounting rails with front and rear manager. Dimensions: 84.0"H x 27.4"W x 15"D (2134mm x 695mm x 381mm)	45	1	0
RNRV6	#12-24 threaded equipment mounting rails with front and rear manager. Dimensions: 84.0"H x 27.1"W x 15"D (2134mm x 689mm x 381mm)	45	1	0
RNRV10	#12-24 threaded equipment mounting rails with front and rear manager. Dimensions: 84.0"H x 30.4"W x 15"D (2134mm x 773mm x 381mm)	45	1	0
2 Post 3" Channel Racks Numbered Up with Single Sided Vertical Cable Managers				
RWMPVF45E	#12-24 threaded equipment mounting rails with a front only manager. Dimensions: 84.0"H x 25.5"W x 15"D (2134mm x 648mm x 381mm)	45	1	0
RWMPVHCF45E	#12-24 threaded equipment mounting rails with a front only manager. Dimensions: 84.0"H x 27.4"W x 15"D (2134mm x 695mm x 381mm)	45	1	0

[^]One rack space = 1.75" (44.45mm).
All product color is black.

PatchRunner™ High Capacity Vertical Cable Management System



Cable Capacity Chart

Part Number	60% Capacity Channel					40% Capacity Channel					RU Capacity	
	Channel Area (in. ²)	Cat. 6A(SD) (0.240" dia.)	Cat. 6A (0.300" dia.)	Cat. 6 (0.240" dia.)	Cat. 5e (0.225" dia.)	Area (in. ²)	Cat. 6A(SD) (0.240" dia.)	Cat. 6A (0.300" dia.)	Cat. 6 (0.240" dia.)	Cat. 5e (0.225" dia.)	Total	
PEV6 (dual-sided) PEVF6 (single sided)	64.8	531	340	531	605	46.2	357	228	357	406	3 rows of 2 RU	6
PEV8 (dual-sided) PEVF8 (single sided)	83.4	733	469	733	834	65	501	320	501	570	3 rows of 3 RU	9
PEV10 (dual-sided) PEVF10 (single sided)	121	936	599	936	1065	83.4	644	412	644	733	3 rows of 4 RU	12
PEV12 (dual-sided) PEVF12 (single sided)	147	1137	728	1147	1294	102	789	505	789	897	3 rows of 6 RU (6 with limited depth)	12/18

A.
System
Overview

B.
Copper
Systems

C.
Fiber
Optic
Systems

D.
Power
over
Ethernet

E.
Zone
Cabling

F.
Wireless

G.
Outlets

H.
Media
Distribution

I.
Physical
Infrastructure
Management

J.
Overhead &
Underfloor
Routing

K.
Surface
Raceway

L.
Cabinets,
Racks &
Cable
Management

M.
Grounding &
Bonding

N.
Industrial

O.
Labeling &
Identification

P.
Cable
Management
Accessories

Q.
Index

PatchRunner™ High Capacity Vertical Cable Managers Roadmap

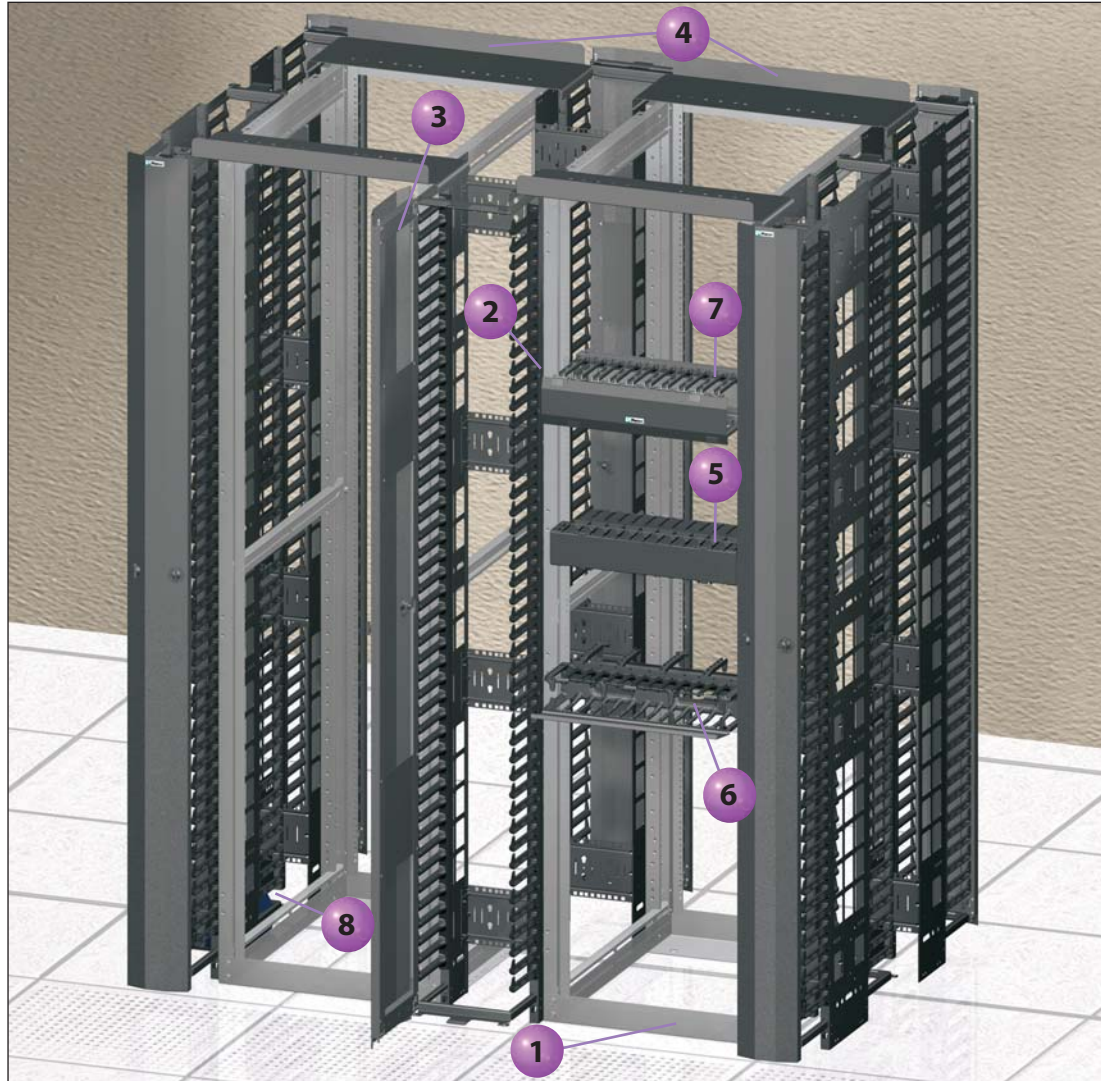

- 1** R4P – 4 Post Rack
84.0"H x 23.25"W x 30.0"D,
45 rack units (RU)
- R4P23 – 4 Post Rack
84.0"H x 23.25"W x 23.0"D,
45 RU (not shown)
- R4P36 – 4 Post Rack
84.0"H x 23.25"W x 36.0"D,
45 RU (not shown)
- R4P42 – 4 Post Rack
84.0"H x 23.25"W x 41.5"D,
45 RU (not shown) (page L.60)
- 2** PatchRunner™ High Capacity
Vertical Cable Managers
Available in 6", 8", 10", and
12" widths (page L.65 – L.68)
- 3** PatchRunner™ High Capacity
Dual Hinged Metal Doors
Available in 6", 8", 10", and 12"
widths (page L.67)

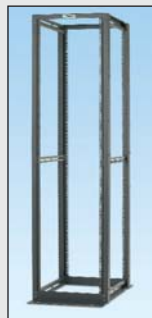

- 4** R4PWF – Rack Top Trough with
Waterfall creates pathway above rack
(page L.61)
- 5** NCMH2 – NetManager™ Horizontal
Cable Manager
(page L.79)
- 6** NM2 – NetManager™ High Capacity
Horizontal Cable Manager
(page L.78)
- 7** PEHF3 – PatchRunner™ High Capacity
Horizontal Cable Manager
(page L.80)
- 8** RFG6X8 – Cool Boot® Raised Floor Air
Sealing Grommet
(pages L.90 and L.91)

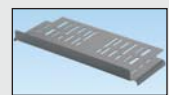

PatchRunner™ High Capacity Vertical Cable Management System

- High density minimizes area required for network layout, freeing up valuable floor space
- Allows mounting of many standard EIA 19" accessories, such as patch panels, vertically in the manager
- Ventilated side walls provide maximum airflow for equipment cooling
- Snap on finger sections can be removed to improve airflow, and break away fingers allow routing of large cable bundles
- Large finger spacing accommodates up to 48 Cat6A cables
- Optional sure close dual hinged metal doors provide easy access to vertical pathway and provides visual and audible feedback on closure
- Available in 7 foot version



PEV



PEVF



PED

Part Number	Part Description	No. of Rack Spaces [^]	Std. Pkg. Qty.	Std. Ctn. Qty.
Vertical Manager – Dual Sided				
PEV6*	High capacity dual sided vertical manager. Dimensions: 83.5"H x 6.0"W x 28.1"D (2120mm x 152mm x 714mm)	45	1	—
PEV8*	High capacity dual sided vertical manager. Dimensions: 83.5"H x 8.0"W x 28.1"D (2120mm x 203mm x 714mm)	45	1	—
PEV10*	High capacity dual sided vertical manager. Dimensions: 83.5"H x 10.0"W x 28.1"D (2120mm x 254mm x 714mm)	45	1	—
PEV12*	High capacity dual sided vertical manager. Dimensions: 83.5"H x 12.0"W x 28.1"D (2120mm x 305mm x 714mm)	45	1	—
Vertical Manager – Single Sided				
PEVF6*	High capacity single sided vertical manager. Dimensions: 83.5"H x 6.0"W x 15.9"D (2120mm x 152mm x 404mm)	45	1	—
PEVF8*	High capacity single sided vertical manager. Dimensions: 83.5"H x 8.0"W x 15.9"D (2120mm x 203mm x 404mm)	45	1	—
PEVF10*	High capacity single sided vertical manager. Dimensions: 83.5"H x 10.0"W x 15.9"D (2120mm x 254mm x 404mm)	45	1	—
PEVF12*	High capacity single sided vertical manager. Dimensions: 83.5"H x 12.0"W x 15.9"D (2120mm x 305mm x 404mm)	45	1	—
PatchRunner™ High Capacity Dual Hinged Doors				
PED6*	Dual hinged metal door. Dimensions: 82.8"H x 6.1"W x 1.7"D (2103mm x 155mm x 43mm)	45	1	—
PED8*	Dual hinged metal door. Dimensions: 82.8"H x 8.1"W x 1.7"D (2103mm x 206mm x 43mm)	45	1	—
PED10*	Dual hinged metal door. Dimensions: 82.8"H x 10.1"W x 1.7"D (2103mm x 256mm x 43mm)	45	1	—
PED12*	Dual hinged metal door. Dimensions: 82.8"H x 12.1"W x 1.7"D (2103mm x 307mm x 43mm)	45	1	—

[^]One rack space = 1.75" (44.45mm).

All product color is black.

* For part numbers that fit 8" rack, add "96" to end of part number. Overall height for managers is 95.5" (2426mm). Overall door height is 94.8" (2409mm).

PatchRunner™ High Capacity Vertical Cable Management System (continued)



PEVBRC



PEVEP



SRB19D5BL



SRB19D7BL



WR5E-X

Part Number	Part Description	No. of Rack Spaces [^]	Std. Pkg. Qty.	Std. Ctn. Qty.
Accessories				
PEVBRC6	Horizontal cross brace bend radius control clips for PatchRunner™ High Capacity Vertical Cable Managers PEV6 and PEVF6.	—	1	10
PEVBRC8	Horizontal cross brace bend radius control clips for PatchRunner™ High Capacity Vertical Cable Managers PEV8 and PEVF8.	—	1	10
PEVBRC10	Horizontal cross brace bend radius control clips for PatchRunner™ High Capacity Vertical Cable Managers PEV10 and PEVF10.	—	1	10
PEVBRC12	Horizontal cross brace bend radius control clips for PatchRunner™ High Capacity Vertical Cable Managers PEV12 and PEVF12.	—	1	10
PEVEP	End Panel. Dimensions: 83.7"H x 23.2"W x .5"D (2125mm x 590mm x 12mm).	—	1	—
SRB19D5BL	Strain relief bar extends 5" off the rack; supports, manages, and provides proper bend radius protection.	—	1	10
SRB19D7BL	Strain relief multi-depth bar extends 7" off the rack; supports, manages, and provides proper bend radius protection. Ideal for use with Category 6A copper cabling installations.	—	1	10
WR5E-X	Snap-on finger cable retainers.	—	10	100

[^]One rack space = 1.75" (44.45mm)
All product color is black

PatchRunner™ Vertical Cable Management Rack System

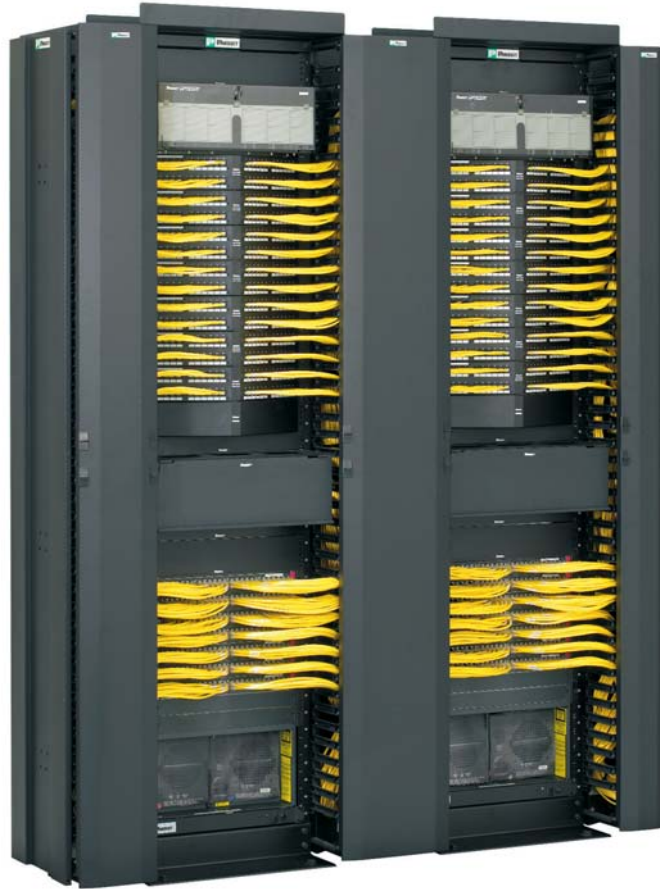

Cable Capacity Chart

Part Number	Front Channel w/ Spool						Front Channel No Spool				Rear Channel				
	Channel Area (In²)	Cable Capacity				Channel Area (In²)	Cable Capacity				Channel Area (In²)	Cable Capacity			
		Cat 6A-SD (0.240)	Cat 6A (0.300)	Cat 6 (0.240)	Cat 5e (0.225)		Cat 6A-SD (0.240)	Cat 6A (0.300)	Cat 6 (0.240)	Cat 5e (0.225)		Cat 6A-SD (0.240)	Cat 6A (0.300)	Cat 6 (0.240)	Cat 5e (0.225)
PRV6* (Dual Sided)	28.22	—	—	—	—	37.8	292	187	292	332	27.6	213	136	213	243
PRVF6* (Single Sided)	28.22	—	—	—	—	37.8	292	187	292	332	—	—	—	—	—
PRV8* (Dual Sided)	44.68	345	221	345	393	54.3	419	268	419	477	39.0	301	193	301	343
PRVF8* (Single Sided)	44.68	345	221	345	393	54.3	419	268	419	477	—	—	—	—	—
PRV10* (Dual Sided)	61.14	473	302	473	538	70.7	547	350	547	622	50.3	389	249	389	443
PRVF10* (Single Sided)	61.14	473	302	473	538	70.7	547	350	547	622	—	—	—	—	—
PRV12* (Dual Sided)	77.6	600	384	600	683	87.2	674	431	674	767	61.7	477	305	477	543
PRVF12* (Single Sided)	77.6	600	384	600	683	87.2	674	431	674	767	—	—	—	—	—
PRV15* (Dual Sided)	102.3	791	506	791	900	111.9	865	554	865	984	78.7	609	389	609	693
PRVF15* (Single Sided)	102.3	791	506	791	900	111.9	865	554	865	984	—	—	—	—	—

Capacities are based on a fill rate of 35% to accommodate proper cable routing techniques. For comparison, multiply by 1.5 for a fill rate of 50%. The above cable diameters represent the nominal Panduit cable diameter per performance level. *For part numbers that are 8 foot tall, add "96" to the end of the part number.

PatchRunner™ Vertical Cable Management Rack System Roadmap

- Vertical cable management system that can manage high-density network equipment and patch panels in up to half the number of racks required by traditional horizontal and vertical cable management systems

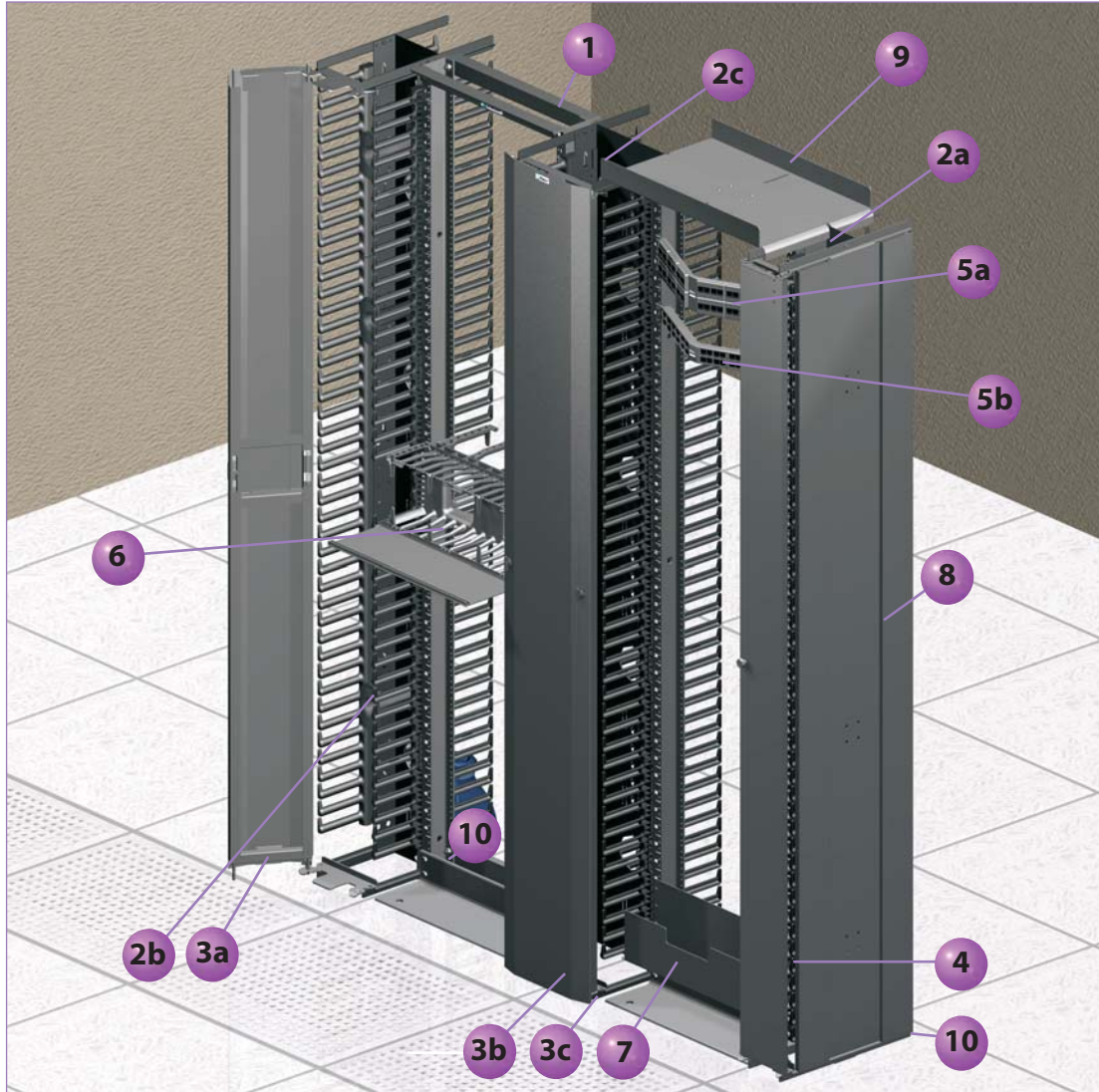

1 R2P – 19" Standard EIA Rack 19" x 7', 45 RU
(page L.63)
PatchRunner™ VERTICAL MANAGERS

- 2a** PRV6 – 6" wide (page L.71)
- 2b** PRV8 – 8" wide (page L.71)
- 2c** PRV12 – 12" wide (page L.71)

HINGED DOORS

- 3a** PRD8 – Dual Hinge, 8" wide (page L.71)
- 3b** PED12 – Dual Hinge, 12" wide (page L.72)
- 3c** PEDK12 – Bracket Kit (page L.72)
- 4** PRSHD6 – Single Hinge, 6" wide (shown) (page L.72)

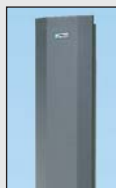

ANGLED MODULAR PATCH PANELS

- 5a** CPPLA48WBLY – 2 RU, 48-Port (page B.69)
- 5b** CPPA48HDWBLY – 1 RU, High Density 48-Port (page B.68)
- 6** NM4 – Cable Pathway, 4 RU (page L.78)
- 7** CMT4 – Trough, 4 RU (page L.82)
- 8** PREP – End Panel (page L.72)
- 9** R2PPRVWF – Rack Top Trough (page L.63)
- 10** RFG6X8 – Cool Boot® Raised Floor Air Sealing Grommet (pages L.90 and L.91)



PatchRunner™ Vertical Cable Management System

- High density minimizes area required for network layout, freeing up valuable floor space
- Curved cable management fingers support cables as they transition to the vertical pathway eliminating the need for horizontal managers
- Individual fingers can be removed without the use of a tool for routing of large cable bundles
- Fingers align with rack spaces simplifying cable routing
- Slack management spools organize and manage patch cord slack allowing standardization of patch cords
- Optional hinged doors provide easy access to vertical pathway; purchased separately from manager
- Available in 7 foot and 8 foot versions



PRV8

PRVF8



PRD

Part Number	Part Description	No. of Rack Spaces [^]	Std. Pkg. Qty.	Std. Ctn. Qty.
Vertical Manager – Manage Cable on Front and Rear of Rack*				
PRV6*‡	Vertical cable manager, spools are not included. Dimensions: 84"H x 6"W x 16.4"D (2133.6mm x 152.4mm x 417mm)	45	1	—
PRV8*	Vertical cable manager, includes four PRSP7 slack spools. Dimensions: 83.9"H x 8.0"W x 16.4"D (2131mm x 203mm x 417mm)	45	1	—
PRV10*	Vertical cable manager, includes four PRSP7 slack spools. Dimensions: 83.9"H x 10.0"W x 16.4"D (2131mm x 254mm x 417mm)	45	1	—
PRV12*‡	Vertical cable manager, includes four PRSP7 slack spools. Dimensions: 83.9"H x 12.0"W x 16.4"D (2131mm x 305mm x 417mm)	45	1	—
PRV15*	Vertical cable manager, includes four PRSP7 slack spools. Dimensions: 83.9"H x 15.0"W x 16.4"D (2131mm x 381mm x 417mm)	45	1	—
Vertical Manager – Manage Cable on Front of Rack Only*				
PRVF6*‡	Vertical cable manager, spools are not included. Dimensions: 83.9"H x 6.0"W x 9.7"D (2131mm x 152mm x 246mm)	45	1	—
PRVF8*	Vertical cable manager, includes four PRSP7 slack spools. Dimensions: 83.9"H x 8.0"W x 9.7"D (2131mm x 203mm x 246mm)	45	1	—
PRVF10*	Vertical cable manager, includes four PRSP7 slack spools. Dimensions: 83.9"H x 10.0"W x 9.7"D (2131mm x 254mm x 246mm)	45	1	—
PRVF12*‡	Vertical cable manager, includes four PRSP7 slack spools. Dimensions: 83.9"H x 12.0"W x 9.7"D (2131mm x 305mm x 246mm)	45	1	—
PRVF15*	Vertical cable manager, includes four PRSP7 slack spools. Dimensions: 83.9"H x 15.0"W x 9.7"D (2131mm x 381mm x 246mm)	45	1	—
PatchRunner™ Doors				
PRD6*‡	Dual hinged metal door. Dimensions: 82.8"H x 6.1"W x 1.6"D (2104mm x 206mm x 40mm)	45	1	—
PRD8*	Dual hinged metal door. Dimensions: 82.8"H x 8.1"W x 1.6"D (2104mm x 206mm x 40mm)	45	1	—
PRD10*	Dual hinged metal door. Dimensions: 82.8"H x 10.1"W x 1.6"D (2104mm x 257mm x 40mm)	45	1	—
PRD12*‡	Dual hinged metal door. Dimensions: 82.8"H x 12.1"W x 1.6"D (2104mm x 308mm x 40mm)	45	1	—

[^]One rack space = 1.75" (44.45mm).

All product color is black.

*For part numbers that fit 8' rack, add "96" to end of part number. Overall height for managers is 95.5" (2426mm). Overall door height is 94.4" (2399mm).

‡For 42 RU add suffix 79 to the end of part number.

PatchRunner™ Vertical Cable Management System (continued)

PRSHD8



PED



PREP



PEDK



PRSP7

Part Number	Part Description	No. of Rack Spaces [^]	Std. Pkg. Qty.	Std. Ctn. Qty.
PRD15*	Dual hinged metal door. Dimensions: 82.8"H x 15.1"W x 1.6"D (2104mm x 384mm x 40mm)	45	1	—
PRSHD6	Single hinged metal door. Dimensions: 80.7"H x 6.0"W x .8"D (2049mm x 152mm x 20mm)	45	1	—
PRSHD8	Single hinged metal door. Dimensions: 80.7"H x 8.0"W x .8"D (2049mm x 203mm x 20mm)	45	1	—
PRSHD12	Single hinged metal door. Dimensions: 80.7"H x 12.0"W x .8"D (2049mm x 305mm x 20mm)	45	1	—

PatchRunner™ High Capacity Dual Hinged Metal Doors

PED6*	Dual hinged metal door. Dimensions: 82.8"H x 6.1"W x 1.7"D (2103mm x 155mm x 43mm)	45	1	—
PED8*	Dual hinged metal door. Dimensions: 82.8"H x 8.1"W x 1.7"D (2103mm x 206mm x 43mm)	45	1	—
PED10*	Dual hinged metal door. Dimensions: 82.8"H x 10.1"W x 1.7"D (2103mm x 256mm x 43mm)	45	1	—
PED12*	Dual hinged metal door. Dimensions: 82.8"H x 12.1"W x 1.7"D (2103mm x 307mm x 43mm)	45	1	—

PED Door Brackets

PEDK6	Bracket kit to allow a PED6 door to be attached to a PRV6 PatchRunner™ Vertical Manager.	—	1	10
PEDK8	Bracket kit to allow a PED8 door to be attached to a PRV8 PatchRunner™ Vertical Manager.	—	1	10
PEDK10	Bracket kit to allow a PED10 door to be attached to a PRV10 PatchRunner™ Vertical Manager.	—	1	10
PEDK12	Bracket kit to allow a PED12 door to be attached to a PRV12 PatchRunner™ Vertical Manager.	—	1	10

Accessories

PRSP7	Molded plastic slack spool, front only. Dimensions: 7.0"D x 1.3" dia. (178mm x 32mm)	—	1	10
PRSP5	Molded plastic slack spool, front or rear. Dimensions: 5.25"D x 1.3" dia. (133mm x 32mm)	—	1	10
PREP*	End panel Dimensions: 82.5"H x 14.5"W x .7"D (2095mm x 367mm x 18mm)	—	1	—
WR5E-X	Snap-on finger cable retainers.	—	10	100

[^]One rack space = 1.75" (44.45mm).

All product color is black.

*For part numbers that fit 8' rack, add "96" to end of part number. Overall height for managers is 95.5" (2426mm).

Overall door height is 94.4" (2399mm).

NetRunner™ High Capacity Vertical Cable Managers Roadmap

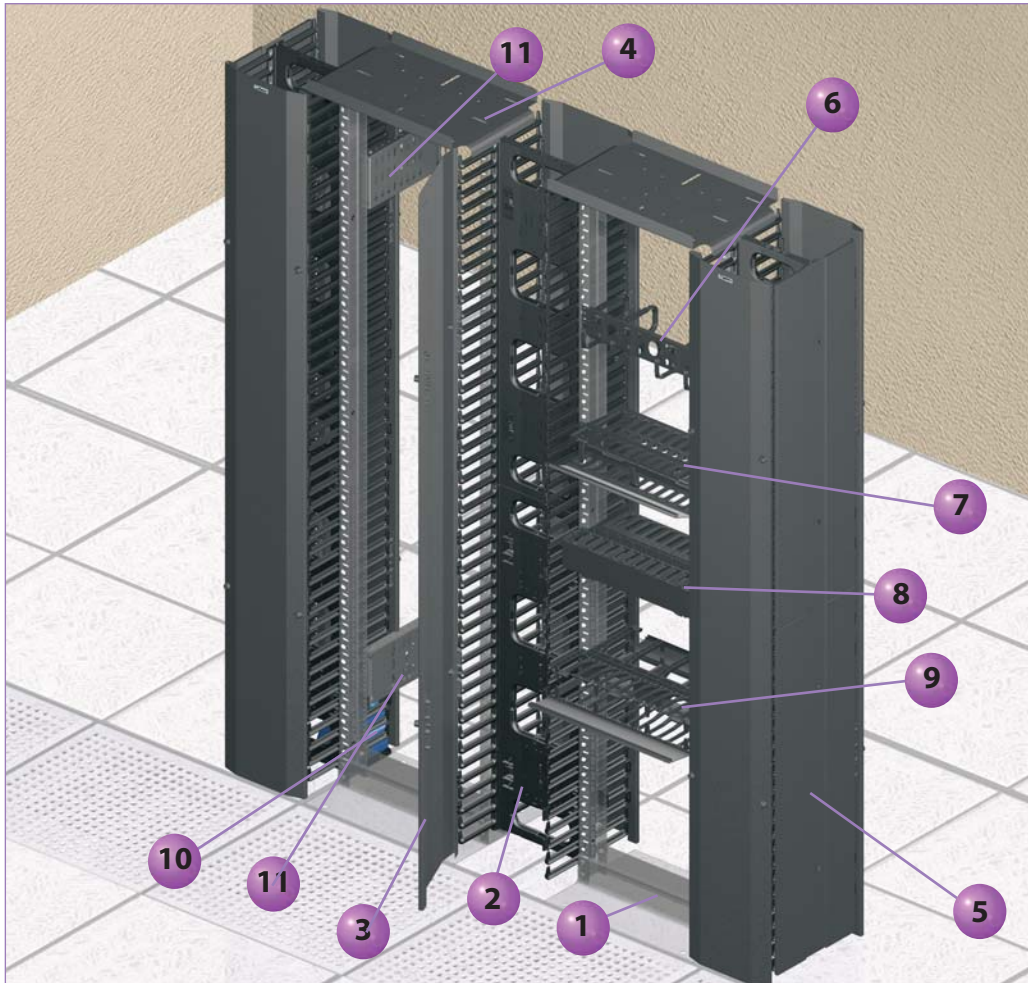

1 R2P – 19" Standard EIA Rack, 19" x 7", 45 RU (page L.63)

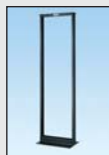

2 NVR12 12" Wide Front and Rear Vertical Manager – 45 RU (page L.74)

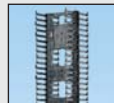

3 NRD12 – Dual Hinged Door Available in 6", 10" and 12" widths (page L.74)



4 WMPV45ERTW – Rack Top Trough with Waterfall creates pathway above rack, for use with R2P (page L.74)



5 NREP (shown) – End Panel for NRV12, NRV10, NVR6 (page L.74)

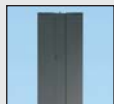

6 CMPH2 – 2 RU Open-Access™ Horizontal Cable Manager D-rings installed on panels Front D-ring size 3"H x 3"D Rear D-ring size 3"H x 5"D Width 19" (pages L.81 and L.82)



7 WMPH2E – 2 RU PatchLink™ Horizontal Cable Manager Front pathway 3"H x 3"D Rear pathway 2"H x 5"D Width 20.2" (page L.77)



8 NCMH2 – Net-Manager™ Horizontal Cable Manager (page L.79)



9 NM2 – 2 RU NetManager™ High Capacity Horizontal Cable Manager (page L.78)



10 RFG6X8 – Cool Boot™ Raised Floor Air Sealing Grommet (page L.90 and L.91)



11 R2PPDUB – Power Outlet Unit (POU) Bracket for 2 and 4 post racks (page L.63)



NetRunner™ High Capacity Vertical Cable Managers

- Large finger openings accommodate up to 24 Category 6A cables
- Push button dual hinged doors ordered separately can be opened 110° to the left or right to provide complete access to the cables inside the vertical pathway
- Snap-on cable retainers can be placed on to fingers to help retain cables in channel during installation and maintenance
- Vertical managers include cable retainers, mounting brackets and #12-24 screws
- Zero RU mounting capability expands the functionality of the vertical manager

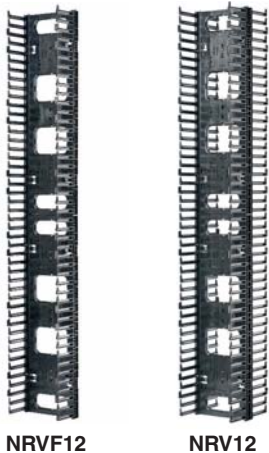

NRVF12

NRV12



NRD12

NREP

Part Number	Part Description	No. of Rack Spaces	Std. Pkg. Qty.	Std. Ctn. Qty.
NRV6	High capacity front and rear vertical manager. Dimensions: 80.4"H x 6.7"W x 13.8"D (2042mm x 170mm x 350mm).	45	1	—
NRV10	High capacity front and rear vertical manager. Dimensions: 80.4"H x 10.0"W x 13.8"D (2042mm x 254mm x 350mm).	45	1	—
NRV12	High capacity front only vertical manager. Dimensions: 80.4"H x 12.0"W x 7.48"D (2042mm x 305mm x 190mm).	45	1	—
NRVF6	High capacity front only vertical manager. Dimensions: 80.4"H x 6.7"W x 7.48"D (2042mm x 170mm x 190mm).	45	1	—
NRVF10	High capacity front only vertical manager. Dimensions: 80.4"H x 10.0"W x 7.48"D (2042mm x 254mm x 190mm).	45	1	—
NRVF12	High capacity front only vertical manager. Dimensions: 80.4"H x 12.0"W x 7.48"D (2042mm x 305mm x 190mm).	45	1	—
NRD6	High capacity dual hinge metal door. Dimensions: 82.8"H x 7.4"W x 1.6"D (2104mm x 188mm x 40mm).	45	1	—
NRD10	High capacity dual hinge metal door. Dimensions: 82.8"H x 10.7"W x 1.6"D (2104mm x 272mm x 40mm).	45	1	—
NRD12	High capacity dual hinge metal door. Dimensions: 82.8"H x 12.7"W x 1.6"D (2104mm x 322mm x 40mm).	45	1	—
NRVCB	NetRunner™ High Capacity Center Mount Bracket Kit allows mounting to adjacent racks. 4 brackets per kit.	—	1	10
NREP	End panel for use with NRV series, WMPVHCF45E/WMPVHC45E. Includes two panel sections to cover 45 RU on one side.	—	1	—
WMPVSMK	NetRunner™ High Capacity Side Mount Hardware Kit for use with R4P 4 post rack series.	—	1	10
WMPV45ERTW	Rack top trough with waterfall creates pathway above rack, for use with SMR19X84 and WMPV45E/WMPVHC45E, NRV.	—	1	—
WR5E-X	Snap-on finger cable retainers.	—	10	100
PRSP5	Molded plastic slack spool, front or rear. Dimensions: 5.25"D x 1.3" dia. (133mm x 32mm)	—	10	100
SRB19BLY	Strain relief bar extends 2" off the rack; supports, manages, and provides proper bend radius protection.	1	1	—

Capacity Chart	Front Channel with Slack Spool					Front Channel with No Slack Spool					Rear Channel					
	Part Number	Channel Area (In²)	Cable Capacity*				Channel Area (In²)	Cable Capacity*				Channel Area (In²)	Cable Capacity*			
			Cat6A-SD (0.240)	Cat6A (0.300)	Cat6 (0.240)	Cat5e (0.225)		Cat6A-SD (0.240)	Cat6A (0.300)	Cat6 (0.240)	Cat5e (0.225)		Cat6A-SD (0.240)	Cat6A (0.300)	Cat6 (.240)	Cat5e (.225)
NRV6 (front/rear)	23.3	180	115	180	205	32.9	254	163	254	289	32.9	254	163	254	289	
NRVF6 (front only)	23.3	180	115	180	205	32.9	254	163	254	289	—	—	—	—	—	
NRV10 (front/rear)	42.8	331	212	331	377	52.4	406	260	406	461	52.4	406	260	406	461	
NRVF10 (front/only)	42.8	331	212	331	377	52.4	406	260	406	461	—	—	—	—	—	
NRV12 (front/rear)	54.6	422	270	422	481	64.2	497	318	497	565	64.2	497	318	497	565	
NRVF12 (front only)	54.6	422	270	422	481	64.2	497	318	497	565	—	—	—	—	—	

*Capacities are based on a fill ratio of 35% to accommodate proper cable routing techniques. For 50% fill ratio, multiply by 1.5. All dimensions represent typical outer cable diameter in inches.



NetRunner™ Vertical Cable Management

- Large finger openings accommodate up to 24 Category 6 cables
- Integral cable retainers on the end of each finger to help contain cables within each rack unit
- Bend radius fingers align with rack spaces to support cables as they transition to the vertical pathway
- Dual hinged covers can be opened 110° to the left or right to provide complete access to the cables inside the vertical pathway
- Snap-on cable retainers can be placed on to fingers to help retain cables in channel during installation and maintenance
- Vertical managers include hinged covers, cable retainers, mounting brackets and #12-24 screws



WMPV22E

WMPVF22E

Part Number	Part Description	No. of Rack Spaces [^]	Std. Pkg. Qty.	Std. Ctn. Qty.
Vertical Cable Managers – Front and Rear				
WMPV22E	Front and rear vertical manager. Dimensions: 41.5"H x 4.9"W x 12.0"D (1054mm x 125mm x 306mm)	22	1	—
WMPVHC45E	Front and rear vertical manager. Dimensions: 83.0"H x 6.7"W x 14.1"D (2108mm x 170mm x 357mm)	45	1	—
WMPV45E	Front and rear vertical manager. Dimensions: 83.0"H x 4.9"W x 12.0"D (2108mm x 125mm x 306mm)	45	1	—
Vertical Cable Managers – Front Only				
WMPVF22E	Front only vertical manager. Dimensions: 41.5"H x 4.9"W x 6.5"D (1054mm x 125mm x 165mm)	22	1	—
WMPVHCF45E	Front only vertical manager. Dimensions: 83.0"H x 6.7"W x 7.6"D (2108mm x 170mm x 192mm)	45	1	—
WMPVF45E	Front only vertical manager. Dimensions: 83.0"H x 4.9"W x 6.5"D (2108mm x 125mm x 165mm)	45	1	—
Accessories				
WMPVCBE	NetRunner™ Center Mount Bracket Kit allows mounting to adjacent racks. Four brackets per kit.	—	1	10
WMPVSMK	NetRunner™ Side Mount Hardware Kit for use with Panduit CMR19X84S racks and Panduit R4P 4 post rack series.	—	1	10
WMPVCMB	Rack adapter bracket kit. Front or back mounted on racks with dimensions up to 1 5/8" (41.1mm) from outside edge of rack to center of the mounting hole. Two kits are required for center mounting of NetRunner™ Managers. Four brackets per kit.	—	1	10
NREP	End panel for use with NRV series, WMPVHCF45E/WMPVHC45E. Includes two panel sections to cover 45 RU on one side.	—	1	—
WMPV45EP	End panel for use with WMPV45E. Includes two panel sections to cover 45 RU on one side.	—	1	—
WMPV45ERTW	Rack top trough with waterfall creates pathway above rack, for use with CMR19X84 and WMPV45E/WMPVHC45E and NRV series.	—	1	—
WR5E-X	Snap-on finger cable retainers.	—	10	100

[^]One rack space = 1.75" (44.45mm).
All product color is black.

Part Number	Cat6A-SD (.240")		Cat 6A (.300")		Cat6 (.240")		Cat5e (.225")	
	Front	Rear	Front	Rear	Front	Rear	Front	Rear
WMPV22E	143	143	91	143	143	143	162	162
WMPVF22E	143	—	91	—	143	—	162	—
WMPV45E	143	143	91	143	143	143	162	162
WMPVF45E	143	—	91	—	143	—	162	—
WMPVHC45E	266	266	170	266	266	266	303	303
WMPVHCF45E	266	—	170	—	266	—	303	—

Note: Capacities are based upon a fill rate of 35% to accommodate proper cable routing techniques.
For comparison, multiply by 1.5 for a fill rate of 50%.

Horizontal Cable Management Rack Systems

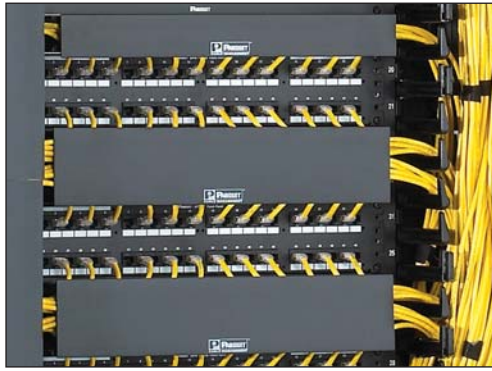

- Panduit® PatchLink™, NetManager™, and Open-Access™ Horizontal Cable Managers manage, protect, and showcase cables between patch panels on 19" EIA racks
- PatchLink™ and NetManager™ Dual Hinged Covers conceal cable pathway and provide easy access without having to remove the door
- Pass-through holes allow front to rear cabling
- For comparison, multiply by 1.25 for a fill rate of 50%
- Capacities are based on a fill rate of 40% to accommodate proper cable routing techniques

PatchLink™ Horizontal Cable Manager



Part Number	Cat 6 (.240")		Cat 5e (.225")	
	Front	Back	Front	Back
WMP1E	60	80	66	90
WMPF1E	60	—	66	—
WMPFSE	24	—	30	—
WMPH2E	60	66	66	66
WMPHF2E	60	—	66	—
WMPLFSE	12	—	16	—
WMPLSE	12	12	16	44
WMPSE	24	25	30	44

NetManager™ High Capacity Horizontal Cable Manager



Part Number	Cat 6A-SD (.240")		Cat 6A (.300")		Cat 6 (.240")		Cat5e (.225")		Fiber (3mm)	
	Front	Back	Front	Back	Front	Back	Front	Back	Front	Back
NM1	30	30	18	18	30	30	34	34	120	120
NM2	84	84	54	54	84	84	96	96	348	348
NM3	144	144	90	90	144	144	168	168	618	618
NM4	210	210	132	132	210	210	240	240	882	882
NMF1	30	—	18	—	34	—	34	—	120	—
NMF2	84	—	54	—	96	—	96	—	348	—
NMF3	144	—	90	—	168	—	168	—	618	—
NMF4	210	—	132	—	240	—	240	—	882	—

NetManager™ Horizontal Cable Manager



Part Number	Cat. 6 (.240")		Cat. 5e (.255")		Fiber (3mm)	
	Front	Back	Front	Back	Front	Back
NCMH2	54	66	60	78	220	352
NCMHF2	54	—	60	—	220	—
NCMHF1	24	—	24	—	88	—

Open-Access™ Horizontal Cable Manager



Part Number	Cat. 6 (.240")		Cat. 5e (.255")		Fiber (3mm)	
	Front	Back	Front	Back	Front	Back
CMPH1	24	26	26	30	88	108
CMPH2	52	96	46	98	203	392
CMPHF1	24	—	24	—	88	—
CMPHHF1	24	—	30	—	107	—
CMPHF2	54	—	60	—	208	—
CMPHH2	96	—	108	—	392	—

All dimensions represent typical outer cable diameter in inches (mm).

PatchLink™ Horizontal Cable Managers

- Lightweight plastic construction provides durability and easy installation
- Patented dual hinged cover allows cable access without removing cover
- Rounded edges on fingers protect cables from snags and damage to cable
- Flexible fingers allows easy installation and removal of cables
- Increased finger spacing provides larger area for high performance Category 6 cables
- Pass-through holes allow front to rear cabling
- Mount to standard 19" EIA racks and cabinets
- Covers, #12-24 and M6 mounting screws included



WMPSE



WMP1E



WMPH2E



WMPFSE



WMPHF2E



WMPF1E



WMPHF2E

Part Number	Part Description	No. of Rack Spaces [^]	Std. Pkg. Qty.
19" Manager, Front and Rear, 1 RU			
WMPLESE	1.7"H x 19.0"W x 7.9"D (44mm x 483mm x 200mm).	1	1
WMPSE	1.7"H x 19.0"W x 8.9"D (44mm x 483mm x 226mm).	1	1
WMPSE-X	1.7"H x 19.0"W x 8.9"D (44mm x 483mm x 226mm). Package of 10.	1	10
19" Manager, Front and Rear, 2 RU			
WMP1E	3.5"H x 19.0"W x 8.9"D (89mm x 483mm x 226mm).	2	1
WMP1E-V	3.5"H x 19.0"W x 8.9"D (89mm x 483mm x 226mm). Package of 5.	2	5
WMPH2E	3.5"H x 20.2"W x 8.9"D (89mm x 513mm x 226mm). Includes extended front covers and two bend radius clips.	2	1
19" Manager, Front Only, 1 RU			
WMPFSE	1.7"H x 19.0"W x 3.7"D (44mm x 483mm x 94mm).	1	1
WMPFSE-E	1.7"H x 19.0"W x 3.7"D (44mm x 483mm x 94mm). Package of 20.	1	20
WMPLEFSE	1.7"H x 19.0"W x 2.7"D (44mm x 483mm x 69mm).	1	1
19" Manager, Front Only, 2 RU			
WMPF1E	3.5"H x 19.0"W x 3.7"D (89mm x 483mm x 94mm).	2	1
WMPF1E-X	3.5"H x 19.0"W x 3.7"D (89mm x 483mm x 94mm). Package of 10.	2	10
WMPHF2E	3.5"H x 20.2"W x 3.7"D (89mm x 573mm x 94mm). Includes extended front covers and two bend radius clips.	2	1

[^]One rack space = 1.75" (44.45mm).
All product color is black.

NetManager™ High Capacity Horizontal Cable Managers

- Innovative inset fingers slope inward toward back of managers offering unobstructed access to network cabling for easier moves, adds, and changes
- Large front finger openings easily accommodate Category 6 and 10 GbE cables, speeding installation and reducing maintenance costs
- Rear cable management finger spacing utilizes open D-rings for greater accessibility
- Can be used to create large capacity horizontal pathways for routing cable
- Patented front and rear dual hinged cover allows cable access without removing cover
- Curved surfaces maintain cable bend radius
- Pass-through holes allow for front to rear cabling
- Built in cable retainers hold cable in place for easy moves, adds, and changes
- Mount to 19" EIA racks and cabinets
- Covers, #12-24 and M6 mounting screws included
- Design fits flush to the front of the NetRunner® High Capacity WMPVHCF45E and WMPVHC45E Vertical Managers



NM2



NMF2



NMF3



NMF4

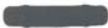

NM1B



NM2B



NM3B



NM4B

Part Number	Part Description	No. of Rack Spaces [^]	Std. Pkg. Qty.
19" High Capacity Manager, Front and Rear			
NM1	Horizontal Cable Manager High Capacity Front and Rear 1 Rack Unit. 1.7"H x 19.0"W x 13.1"D (44mm x 482mm x 332mm).	—	1
NM2	Horizontal Cable Manager High Capacity Front and Rear 2 Rack Units. 3.5"H x 19.0"W x 13.1"D (88mm x 482mm x 332mm).	—	1
NM3	Horizontal Cable Manager High Capacity Front and Rear 3 Rack Units. 5.2"H x 19.0"W x 13.1"D (133mm x 482mm x 332mm).	—	1
NM4	Horizontal Cable Manager High Capacity Front and Rear 4 Rack Units. 7.0"H x 19.0"W x 13.1"D (177mm x 482mm x 332mm).	—	1

19" High Capacity Manager, Front Only			
NMF1	Horizontal Cable Manager High Capacity Front Only 1 Rack Unit. 1.7"H x 19.0"W x 6.2"D (44mm x 482mm x 157mm).	1	1
NMF2	Horizontal Cable Manager High Capacity Front Only 2 Rack Units. 3.5"H x 19.0"W x 6.2"D (88mm x 482mm x 157mm).	2	1
NMF3	Horizontal Cable Manager High Capacity Front Only 3 Rack Units. 5.2"H x 19.0"W x 6.2"D (133mm x 482mm x 157mm).	3	1
NMF4	Horizontal Cable Manager High Capacity Front Only 4 Rack Units. 7.0"H x 19.0"W x 6.2"D (177mm x 482mm x 157mm).	4	1

Accessories			
NM1B	Front to rear pass through blanking panel for NetManager™ High Capacity Horizontal Cable Managers, NM1 and NMF1.	—	1
NM2B	Front to rear pass through blanking panel for NetManager™ High Capacity Horizontal Cable Managers, NM2 and NMF2.	—	1
NM3B	Front to rear pass through blanking panel for NetManager™ High Capacity Horizontal Cable Managers, NM3 and NMF3.	—	1
NM4B	Front to rear pass through blanking panel for NetManager™ High Capacity Horizontal Cable Managers, NM4 and NMF4.	—	1

[^]One rack space = 1.75" (44.5mm).
All product color is black.

NetManager® Horizontal Cable Managers

- Patented design
- Lightweight plastic construction provides durability and easy installation
- Removable front cover hinges 180° up or down to allow access without removing cover
- Curved surfaces maintain cable bend radius
- Pass-through holes allow for front to rear cabling
- Built in cable retainers hold cable in place for easy moves, adds, and changes
- Mount to 19" EIA racks and cabinets
- Covers, #12-24 and M6 mounting screws included



NCMHF1



NCMH2

Part Number	Part Description	No. of Rack Spaces^	Std. Pkg. Qty.
NCMHF1	1.7"H x 19.0"W x 3.7"D (44mm x 483mm x 95mm).	1	1
NCMHF2	3.5"H x 19.0"W x 3.7"D (88mm x 483mm x 95mm).	2	1
NCMH2	3.5"H x 19.0"W x 9.8"D (88mm x 483mm x 248mm). Snap-on rear cover.	2	1

^One rack space = 1.75" (44.45mm).
All product color is black.

PatchRunner™ High Capacity Horizontal Cable Managers

- Manage cables on switches with vertical cards
- Curved cable management fingers support cables as they transition to the vertical pathway
- Can be used to create cable pathways for routing cable
- Steel hinged cover provides easy access to pathway
- Pass-through holes on top and back of manager
- Mount to 19" EIA racks and cabinets
- Mounting hardware included



PEHF2



PEHF3



PEHF4

Part Number	Part Description	No. of Rack Spaces [^]	Cable Capacity					Std. Pkg. Qty.
			Cat 6A-SD (.240")	Cat 6A (.300")	Cat 6 (.240")	Cat 5e (.225")	Fiber (3mm)	
PEHF2	PatchRunner™ High Capacity Horizontal Cable Manager with hinged cover, front only, 2 RU. Dimensions: 3.5"H x 18.9"W x 9.8"D* (89mm x 480mm x 250mm*) *Depth can telescope from rack mounting face 4.4" (112mm) to 7.6" (193mm).	2	143	92	143	163	592	1
PEHF3	PatchRunner™ High Capacity Horizontal Cable Manager with hinged cover, front only, 3 RU. Dimensions: 5.2"H x 18.9"W x 9.8"D* (133mm x 480mm x 250mm*) *Depth can telescope from rack mounting face 4.4" (112mm) to 7.6" (193mm).	3	259	166	259	295	1072	1
PEHF4	PatchRunner™ High Capacity Horizontal Cable Manager with hinged cover, front only, 4 RU. Dimensions: 7.0"H x 18.9"W x 9.8"D* (177mm x 480mm x 250mm*) *Depth can telescope from rack mounting face 4.4" (112mm) to 7.6" (193mm).	4	375	240	375	427	1551	1

[^]One rack space = 1.75" (44.45mm).
All product color is black.

Open-Access™ Horizontal Cable Managers

- D-ring managers provide an open and efficient way to manage cable
- Patented D-ring design provides flexibility for easy moves, adds, and changes
- Optional snap-on cover
- Pass-through holes allow front to rear cabling
- Mount to 19" EIA racks and cabinets
- Hardware included



CMPH1



CMPH2



CMPHF1



CMPHHF1



CMPHF2



CMPHH2

Part Number	Part Description	No. of Rack Spaces [^]	Std. Pkg. Qty.
19" Manager, Front and Rear, 1 RU			
CMPH1	D-rings installed on panels. 1.7"H x 19.0"W x 8.6"D (44mm x 483mm x 218mm).	1	1
19" Manager, Front and Rear, 2 RU			
CMPH2	D-rings installed on panel. 3.5"H x 19.0"W x 8.6"D (88mm x 483mm x 218mm).	2	1
19" Manager, Front Only, 1 RU			
CMPHF1	D-rings installed on panel. 1.7"H x 19.0"W x 3.4"D (44mm x 483mm x 87mm).	1	1
CMPHHF1	D-rings installed on panel. 1.7"H x 19.0"W x 5.7"D (44mm x 483mm x 144mm).	1	1
19" Manager, Front Only, 2 RU			
CMPHF2	D-rings installed on panel. 3.5"H x 19.0"W x 3.4"D (88mm x 483mm x 87mm).	2	1
CMPHH2	D-rings installed on panel. 3.5"H x 19.0"W x 5.7"D (88mm x 483mm x 144mm).	2	1
Optional Covers			
CMPH1C	Snap-on cover for 1 RU D-ring panels. Width 19.4" (492mm).	1	1
CMPH2C	Snap-on cover for 2 RU D-ring panels. Width 19.4" (492mm).	2	1

[^]One rack space = 1.75" (44.45mm).
All product color is black.

PATENTED Vertical D-Rings

- Patented cable manager ring
- Standard EIA hole spacing allows product to be mounted to any standard rack
- Flexible material allows arm to rotate so entire cable bundle can be inserted and removed
- Rounded edges prevent damage to cable insulation
- 1/4" (M6) mounting hole allows for a variety of screws to secure the D-ring to a surface
- Create a structured pathway and allows for open access
- Material: Black Flame Retardant Polycarbonate



Part Number	Part Description	Cable Capacity			Std. Pkg. Qty.
		Cat 6A (0.300")	Cat 6 (0.240")	Cat 5e (0.225")	
CMVDR1	Vertical D-ring. Outside dimensions 5.72"L x 2.05"W (145.3mm x 52.1mm).	40	62	70	1
CMVDR1S	Vertical D-ring. Outside dimensions 3.26"L x 2.05"W (82.8mm x 52.1mm).	20	30	35	1
CMVDR2	Vertical D-ring. Outside dimensions 5.72"L x 3.30"W (145.3mm x 83.8mm).	82	128	144	1
CMVDR2S	Vertical D-ring. Outside dimensions 3.26"L x 3.30"W (82.8mm x 83.8mm).	40	62	70	1
CMVDRC	Center mounted vertical D-ring for routing cables between two adjacent racks. Requires 8.25" spacing between the center lines of the adjacent rack's mounting holes. Outside dimensions 5.66"L x 8.75"W (143.8mm x 222.3mm).	170	265	300	1

Cable Routing Troughs

- Provide pathways to route cables in a rack line-up



Part Number	Part Description	Cable Capacity					Std. Pkg. Qty.
		Cat. 6A (.298")	Cat. 6A (.289")	Cat. 6 (.250")	Cat. 5e (.187")	Fiber (3mm)	
CMLT19	4 RU lower trough with 1.3" bend radius mounts to the bottom of a standard 19" EIA rack. Dimensions: 8.0"H x 19.0"W x 4.5"D (203mm x 483mm x 114mm).	85	106	125	224	564	1
CMUT19	2 RU upper trough with 1.3" bend radius mounts to the top of a standard 19" EIA rack. Dimensions: 3.5."H x 19.0"W x 4.5"D (89mm x 483mm x 114mm).	57	70	83	148	373	1
CMT4	4 RU cable routing trough. Dimensions: 6.9"H x 19.0"W x 4.5"D (176mm x 483mm x 114mm).	152	12488	223	399	1002	1

One rack space = 1.75" (44.45mm).
 All product color is black.
 All dimensions represent typical outer cable diameter in inches (mm).

Rack Mount Shelves

- Load ratings up to 250 lbs. refer to part descriptions for specific load ratings



SRM19FM2



SRM19CMV3



SRM19X18A1

Part Number	Part Description	No. of Rack Spaces^	Std. Pkg. Qty.
SRM19FM1	19" front mount shelf, steel. Dimensions: 1.7"H x 19.0"W x 15.2"D (44mm x 483mm x 385mm). Load rating 30 lbs.	1	1
SRM19FM2	19" front mount shelf, steel. Dimensions: 3.5"H x 19.0"W x 15.2"D (88mm x 483mm x 385mm). Load rating 50 lbs.	2	1
SRM19CMV3	19" cantilevered shelf, vented aluminum. Includes two-piece shelf that mounts to front and back of EIA racks. Dimensions: 5.2"H x 19.2"W x 12.5"D (133mm x 489mm x 316mm). Load rating 200 lbs.	3	1
SRM19CM3	19" cantilevered shelf, aluminum. Includes two-piece shelf that mounts to front and back of EIA racks. Dimensions: 5.2"H x 19.2"W x 12.5"D (133mm x 489mm x 316mm). Load rating 200 lbs.	3	1
SRM19X18A1	19" adjustable mount shelf, steel, mounts to front and back of EIA racks. Dimensions: 1.8"H x 19.0"W x 18.0"D (44mm x 483mm x 457mm). Load rating 250 lbs.	1	1
SRM19X25A1	19" adjustable mount shelf, steel, mounts to front and back of EIA racks. Dimensions: 1.8"H x 19.0"W x 25.0"D (44mm x 483mm x 635mm). Load rating 250 lbs.	1	1

^One rack space = 1.75" (44.45mm).
All product color is black.

Panel Extender Brackets

- Allow for mounting 19" product on 23" standard EIA racks or cabinets
- Offset bracket design maintains flush mounting of panels
- Mounting hardware included



PEB1



PEB2

Part Number	Part Description	No. of Rack Spaces^	Std. Pkg. Qty.	Std. Ctn. Qty.
PEB1	Converts 19" horizontal panels to 23" panels.	1	1	10
PEB2	Converts 19" horizontal panels to 23" panels.	2	1	10

^One rack space = 1.75". (44.45mm).
All product color is black.

Rack Mount Cable Management Accessories

- Bend radius control fingers support cables as they transition to the vertical pathway
- Finger spacing aligns with rack units
- Attach to patch panels or equipment mounting screws
- Lightweight plastic construction provides durability and easy installation



CMBRC1



CMBRC5E

Part Number	Part Description	No. of Rack Spaces [^]	Std. Ctn. Qty.
CMBRC1	Kit of two bend radius control fingers; for use with patch panels. Maintains 1/2" bend radius control. Dimensions: 1.7"H x .8" W x 3.0"D (44mm x 19mm x 77mm).	1	10
CMBRC1E	Kit of two bend radius control fingers, for use with patch panels. Maintains 1/2" bend radius control. Dimensions: 1.7"H x 1.0"W x 5.1"D (44mm x 25mm x 129mm).	1	10
CMBRC5	One-piece unit with five bend radius control fingers; for use with active equipment. Maintains 1/4" bend radius control. Dimensions: 8.7"H x 1.0"W x 3.3"D (222mm x 26mm x 84mm).	5	10
CMBRC5E	One-piece unit with five bend radius control fingers; for use with active equipment. Maintains 1/4" bend radius control. Dimensions: 8.7"H x 1.0"W x 5.1"D (222mm x 26mm x 129mm).	5	10

[^]One rack space = 1.75" (44.45mm).
All product color is black.

Hinged Wall Brackets

- Mount to wall or standard EIA 19" rack
- Cable tie slots
- Standard 19" EIA hole spacing
- Panel rotates from one side for easy access to cabling
- Include write-on labeling area
- Accept 19" patch panels, horizontal managers, and equipment



WBH1



WBH2



WBH3



WBH4



WBH4E

Part Number	Part Description	No. of Rack Spaces [^]	Std. Pkg. Qty.
6" Deep Wall Brackets			
WBH1	Dimensions: 1.8"H x 20.2"W x 6.3"D (44mm x 513mm x 159mm). Load rating 10 lbs.	1	1
WBH2	Dimensions: 3.5"H x 20.2"W x 6.3"D (89mm x 513mm x 159mm). Load rating 20 lbs.	2	1
WBH3	Dimensions: 5.3"H x 20.2"W x 6.3"D (133mm x 513mm x 159mm). Load rating 30 lbs.	3	1
WBH4	Dimensions: 7.0"H x 20.2"W x 6.3"D (178mm x 513mm x 159mm). Load rating 40 lbs.	4	1
15" Deep Wall Brackets			
WBH2E	Dimensions: 3.5"H x 20.4"W x 15.8"D (89mm x 519mm x 402mm). Load rating 20 lbs.	2	1
WBH4E	Dimensions: 7.0"H x 20.4"W x 15.8"D (177mm x 519mm x 402mm). Load rating 40 lbs.	4	1
WBH6E	Dimensions: 10.5"H x 20.4"W x 15.8"D (267mm x 519mm x 402mm). Load rating 60 lbs.	6	1

[^]One rack space = 1.75" (44.45mm).
All product color is black.

Full-Length Blanking Shade

- Adjustable blanking solution that can blank out as few as 4 or as many as 45 rack units
- Requires no tools or hardware to install
- Easy and efficient installation and deployment
- Can easily be raised or lowered to allow service to components within the cabinet



Part Number	Part Description	No. of Rack Spaces	Std. Pkg. Qty.
FLBSIM-Y	Full-length blanking shade blanks out 4-45 consecutive rack units on standard 19.00" (482.6mm) wide vertical mounting rails; black.	4-45	1

Tool-Less Blanking Panels

- Minimize bypass airflow in standard EIA 19" racks and cabinets while providing an aesthetic appearance
- Require no tools or hardware to install



TLBP1



TLBP2

Part Number	Part Description	No. of Rack Spaces [^]	Std. Pkg. Qty.
TLBP1S-V	19" (483mm) width for 3/8" cage nut holes (may be used with or without cage nuts installed). 1 RU.	1	5
TLBP2S-V	19" (483mm) width for 3/8" cage nut holes (may be used with or without cage nuts installed). 2 RU.	2	5
TLBP1R-V	19" (483mm) width for tapped rails. 1 RU.	1	5
TLBP2R-V	19" (483mm) width for tapped rails. 2 RU.	2	5

[^]One rack space = 1.75" (44.45mm).
All product color is black.

Rack Filler Panels

- Reserve rack space for future use
- Direct airflow in cabinet applications
- Mount to standard EIA 19" racks or cabinets
- #12-24 and M6 mounting screws included



DPFP1



DPFP2



DPFP4



DPFP8



DPFPA1

Part Number	Part Description	No. of Rack Spaces [^]	Std. Pkg. Qty.	Std. Ctn. Qty.
DPFP1	Dimensions: 1.8"H x 19.0"W (44mm x 483mm).	1	1	10
DPFP2	Dimensions: 3.5"H x 19.0"W (89mm x 483mm).	2	1	10
DPFP4	Dimensions: 7.0"H x 19.0"W (178mm x 483mm).	4	1	10
DPFP8	Dimensions: 14.0"H x 19.0"W (355mm x 483mm).	8	1	10
DPFPA1	1RU adjustable blanking panel.	—	1	10

[^]One rack space = 1.75" (44.45mm).
All product color is black.



Angled Panel Accessories

- Aesthetic design provides a clean and consistent look when used with Panduit angled patch panels
- Support warm aisle/cold aisle methodology by sealing in cool air and not allowing it to escape, promoting proper airflow and cooling
- Protect exposed connectors from intrusion of debris or accidental disconnection



CPAF1BLY



CPAF2BLY



CPATCBL

Part Number	Part Description	No. of Rack Spaces [^]	Std. Pkg. Qty.	Std. Ctn. Qty.
CPAF1BLY	Covers one open rack space in standard EIA 19" rack.	1	1	10
CPAF2BLY	Covers two open rack spaces in standard EIA 19" rack.	2	1	10
CPATCBL	Transitional cover for angled patch panels that occupies zero rack space.	0	1	10

[^]One rack space = 1.75" (44.45mm).
All product color is black.

IN-Cabinet Vertical Cable Managers

- For managing cable within cabinets 27" or wider
- Attach to equipment mounting rails
- Two mounting bracket options to facilitate mounting to various cabinet configurations
- Snap-on covers included



Front Mount Bracket



Side Mount Bracket



CWMPV3340

Part Number	Part Description	No. of Rack Spaces [^]	Std. Pkg. Qty.
Side Mount – Front Only			
CWMPV3440	Duct with side mount bracket, cage nut, and screws. Dimensions: 71.9"H x 3.5"W x 4.3"D (1825mm x 88mm x 109mm). Capacity: 96 cables .187 dia.	40	1
CWMPV2440	Duct with side mount bracket, cage nut, and screws. Dimensions: 71.9"H x 2.5"W x 4.3"D (1825mm x 63mm x 109mm). Capacity: 60 cables .187 dia.	40	1
Front Mount – Front Only			
CWMPV2340	Duct with front mount bracket, cage nut, and screws. Dimensions: 70.0"H x 3.7"W x 3.3"D (1778mm x 94mm x 83mm). Capacity: 48 cables .187 dia.	40	1
CWMPV3340	Duct with front mount bracket, cage nut, and screws. Dimensions: 70.0"H x 4.7"W x 3.3"D (1778mm x 119mm x 83mm). Capacity: 72 cables .187 dia.	40	1

[^]One rack space = 1.75" (44.45mm).
All product color is black.

Cable Capacity Chart

Part Number	Cat 6 (.240")	Cat 5e (.225")	Fiber (3mm)
CWMPV3440	116	132	386
CWMPV2440	83	74	225
CWMPV2340	94	107	377
CWMPV3340	119	136	479



Communication Cable Management Kit for Cabinets

- Kit of cable management accessories specifically designed for use in a network cabinet or enclosure



Part Number	Part Description	Std. Pkg. Qty.*	Std. Ctn. Qty.
CCMKIT1	Kit includes the following: 1 roll (15' (4.6m) length) .33" (8.4mm) Tak-Ty® Cable Ties 24 nylon cable ties 12 adhesive backed cable tie mounts 6 push style cable tie mounts 4 vertical wire saddles 8 flat Pan-Post® Standoffs for use with std. nylon cable ties	1	100
CCMKIT2	Kit includes the following: 1 roll (15' (4.6m) length) .75" (19.1mm) Tak-Ty® Cable Ties 12 nylon cable ties 6 adhesive backed cable tie mounts 6 adhesive backed mounts for .75" (19.1mm) Tak-Ty® Cable Ties 6 screw mounts for .75" (19.1mm) Tak-Ty® Cable Ties 4 vertical wire saddles 6 flat Pan-Post® Standoffs for use with .75" (19.1mm) Tak-Ty® Cable Ties	1	100

*Order the number of kits required.

Flat Pan-Post™ Standoffs

- Standard EIA hole spacing allows product to be mounted with user supplied screws up to 1/4" (M6) diameter
- Organize cables in standard cabinets and racks
- Use where space is limited
- For indoor use only
- Material: Natural Nylon 6.6



Part Number	Part Description	Std. Pkg. Qty.	Std. Ctn. Qty.
Flat Pan-Post™ Standoff for Nylon Cable Ties			
PPF2S-S25-V	Nylon 6.6 flat Pan-Post™ Standoff. Use with miniature, intermediate, and standard cross section cable ties. Dimensions 5.42"L x 1.50"H x .19"W (137.7mm x 38.1mm x 4.8mm).	5	100
PPF2S-S25-V69	Flame retardant nylon 6.6 flat Pan-Post™ Standoff. Use with miniature, intermediate, and standard cross section cable ties. Material meets UL 94V-0 specifications. Dimensions 5.42"L x 1.50"H x .19"W (137.7mm x 38.1mm x 4.8mm).	5	100
Flat Pan-Post™ Standoff for Tak-Ty® Hook & Loop Cable Ties			
PPF2SV-S25-V	Nylon 6.6 flat Pan-Post™ Standoff. Use with Tak-Ty® Hook & Loop Cable Ties. Dimensions 5.60"L x 1.62"H x .19"W (142.2mm x 41.3mm x 4.8mm).	5	100
PPF2SV-S25-V69	Flame retardant nylon 6.6 flat Pan-Post™ Standoff. Use with Tak-Ty® Hook & Loop Cable Ties. Material meets UL 94V-0 specifications. Dimensions 5.60"L x 1.62"H x .19"W (142.2mm x 41.3mm x 4.8mm).	5	100

Pan-Post[®] Standoffs

- Support cable bundles above or away from surface
- For indoor use only
- Material: Natural Nylon 6.6



Part Number	Part Description	Std. Pkg. Qty.	Std. Ctn. Qty.
PP1S-S10-X	Pan-Post™ Standoff, mounting method #10/M5 screw, 1.06"L x .72"W x 1.97"H (26.9mm x 18.3mm x 50.0mm). Used with cable ties M,I,S.	10	100
PP1S-S12-X	Pan-Post™ Standoff, mounting method #12/M5.5 screw, 1.06"L x .72"W x 1.97"H (26.9mm x 18.3mm x 50.0mm). Used with cable ties M,I,S.	10	100
PP2S-S10-X	Pan-Post™ Standoff, mounting method #10/M5 screw, 1.06"L x .72"W x 4.60"H (26.9mm x 18.3mm x 116.9mm). Used with cable ties M,I,S.	10	100
PP2S-S12-X	Pan-Post™ Standoff, mounting method #12/M5.5 screw, 1.06"L x .72"W x 4.60"H (26.9mm x 18.3mm x 116.9mm). Used with cable ties M,I,S.	10	100

Cable tie cross section sizes: M = Miniature, I = Intermediate, S = Standard.

Bundle Retainers

- Support cable in vertical or horizontal configurations
- Spring fingers with large lead-in facilitates insertion of cable bundles
- Adhesive backed and screw applied versions available
- Material: Black Nylon 6.6



BR2-1.3-A

Part Number	Part Description	Std. Pkg. Qty.	Std. Ctn. Qty.
BR2-1.3	Standard EIA hole spacing for mounting. Maximum bundle capacity: 2.00" (50.8mm).	1	10
BR2-1.3-A	Adhesive base and standard EIA hole spacing provides mounting options. Maximum bundle capacity: 2.00" (50.8mm).	1	10

Cable Management Accessories Roadmap

- Organize cable in a variety of applications providing a standards compliant installation to reduce stress on cable while allowing for easier moves, adds, and changes.

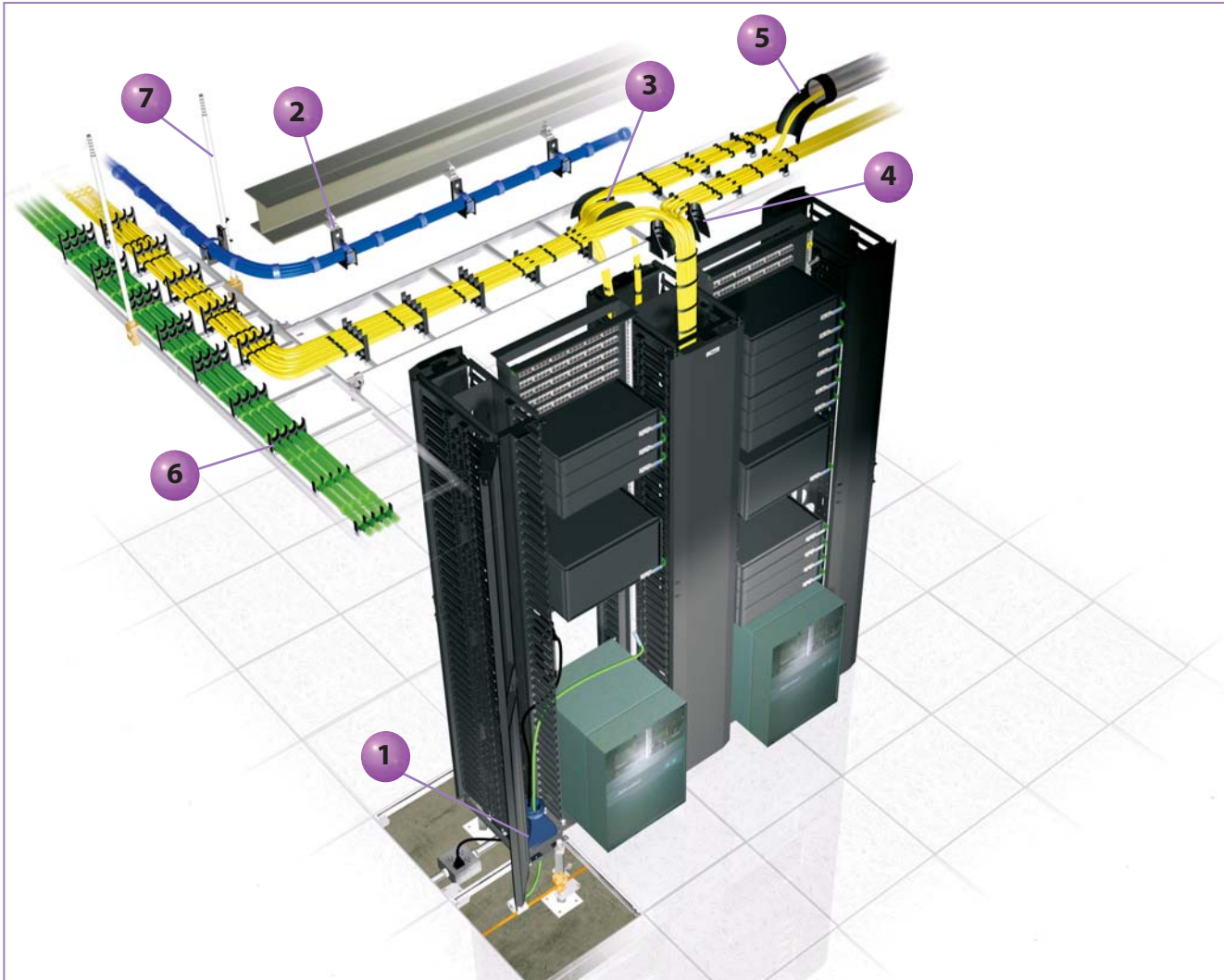

<p>1 Cool Boot® Raised Floor Air Sealing Grommet (pages L.90 and L.91)</p> 	<p>4 Waterfall Accessories (pages L.98 and L.99)</p> 
<p>2 J-Pro™ Cable Support System (pages L.92 – L.94)</p> 	<p>5 Conduit Waterfall (page L.98)</p> 
<p>3 Double Waterfall Accessory (page L.99)</p> 	<p>6 Stackable Cable Rack Spacers (page L.100)</p> 
	<p>7 Threaded Rod Cover (page L.99)</p> 

PATENTED**Cool Boot[®] Raised Floor Air Sealing Grommet**

- Airtight fabric minimizes bypass of air through cutouts in the raised floor to improve cooling of network equipment, minimizing the risk of overheating
- Ultra Cinch[™] Tie closes top of fabric to prevent air from escaping around cable bundles
- Electrostatic dissipative material provides a pathway to ground reducing the chance of damaging network equipment with electric shock
- Vertical Tak-Ty[®] Hook & Loop Cable Tie closure system allows for installation on existing cable bundles
- Horizontal Tak-Ty[®] Hook & Loop Cable Tie closure system allows two or more bundles to be separated in existing or new installations
- Flexible polycarbonate outer ring houses fabric to allow user to secure product to raised floor tile; slit allows outer ring to flex so entire cable bundle can be inserted to allow for retrofit installations even when vertical cable managers are already in place
- Low profile polycarbonate outer ring extends 7/16" (11.1mm) above top of raised floor tile to allow compatibility with vertical cable managers
- Self-tapping #10 screws (included) allow a secure fastening method to top of raised floor tile, also providing a pathway to ground
- Material: Black electrostatic dissipative flame retardant polycarbonate outer ring with navy blue electrostatic dissipative flame retardant fabric
- Manufactured from flame retardant materials

**RFG*X*SMY****RFG*X*Y**

Part Number	Part Description	Cable Capacity			Std. Pkg. Qty.	Std. Ctn. Qty.
		Cat. 6A (0.300")	Cat. 6 (0.240")	Cat. 5e (0.225")		
Surface Mount						
RFG6X8SMY	Overall size of 6" x 8" (152.4mm x 203.2mm) allows for 4.2" x 6.2" (106.7mm x 157.5mm) capacity.	183	287	326	1	10
RFG8X8SMY	Overall size of 8" x 8" (203.2mm x 203.2mm) allows for 6.2" x 6.2" (157.5mm x 157.5mm) capacity.	271	424	482	1	10
RFG10X8SMY	Overall size of 10" x 8" (254.0mm x 203.2mm) allows for 8.2" x 6.2" (208.3mm x 157.5mm) capacity.	359	561	638	1	10
RFG12X4SMY	Overall size of 12" x 4" (304.8mm x 101.6mm) allows for 10.2" x 2.2" (259.1mm x 55.9mm) capacity.	158	247	281	1	10
RFG12X8SMY	Overall size of 12" x 8" (304.8mm x 203.2mm) allows for 10.2" x 6.2" (259.1mm x 157.5mm) capacity.	447	698	794	1	10
RFG3DSMY	Overall size of 4.8" (121.9mm) diameter allows for 2.7" (68.6mm) diameter capacity.	40	62	71	1	10
RFG5DSMY	Overall size of 6.8" (172.7mm) diameter allows for 4.7" (119.4mm) diameter capacity.	122	191	217	1	10

Integral Mount*

RFG6X8Y	Overall size of 6" x 8" (152.4mm x 203.2mm) allows for 4.2" x 6.2" (106.7mm x 157.5mm) capacity.	183	287	326	1	10
RFG8X8Y	Overall size of 8" x 8" (203.2mm x 203.2mm) allows for 6.2" x 6.2" (157.5mm x 157.5mm) capacity.	271	424	482	1	10
RFG10X8Y	Overall size of 10" x 8" (254.0mm x 203.2mm) allows for 8.2" x 6.2" (208.3mm x 157.5mm) capacity.	359	561	638	1	10
RFG12X4Y	Overall size of 12" x 4" (304.8mm x 101.6mm) allows for 10.2" x 2.2" (259.1mm x 55.9mm) capacity.	158	247	281	1	10
RFG12X8Y	Overall size of 12" x 8" (304.8mm x 203.3mm) allows for 10.2" x 6.2" (259.1mm x 157.5mm) capacity.	447	698	794	1	10
RFG3DY	Overall size of 4.8" (121.9mm) diameter allows for 2.7" (68.6mm) diameter capacity.	40	62	71	1	10
RFG5DY	Overall size of 6.8" (172.7mm) diameter allows for 4.7" (119.4mm) diameter capacity.	122	191	217	1	10

Product complies with Article 645 Section 5(D)(4) of the 2005 National Electrical Code.

Compatible with NetRunner[™] and PatchRunner[™] Cable Managers, and Panduit[®] Net-Access[™] Cabinets to create a complete cable management system.

*Integral products include a flexible sub-grommet to prevent damage to cable from sharp edges of cut floor tile.

Cool Boot® Raised Floor Air Sealing Grommet (continued)

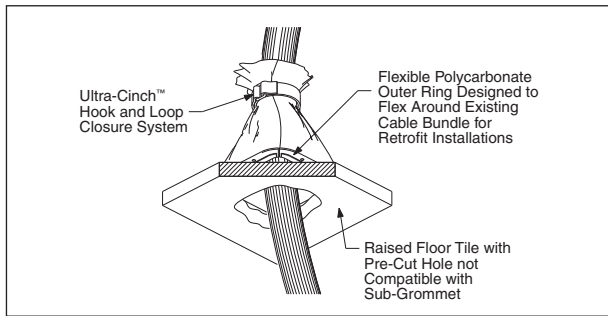

Surface Mount Application

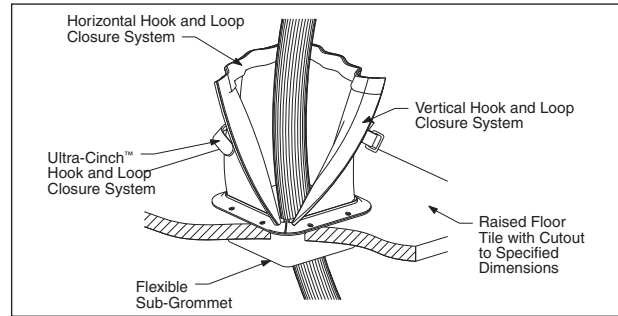

Integral Mount Application



PATENTED

J-Pro™ Cable Support System

- Patented design provides complete horizontal and vertical 1" bend radius control that helps prevent degradation of cable performance
- UL 2043 and CAN/ULC S102.2 listed and suitable for use in air handling spaces
- Pre-rieveted assemblies allow for attachment to walls, ceilings, beams, threaded rods, drop wires and underfloor supports to meet requirements of a variety of applications
- Wide cable support base prevents pinch points that could cause damage to cables
- Cable tie channel allows user to easily install 3/4" (19.1mm) Tak-Ty® Cable Ties to retain cable bundle
- Durable non-metallic J Hook materials provide the ability to manage and support a large number of cables
- Material: Black Nylon 6.6 J Hook with metal attachments



JP2W-L20



JP2WP2-L20



JP2CM-L20



JP2DW-L20

Part Number	Part Description	Max. Bundle Capacity		Max. Cable Capacity			Std. Pkg. Qty.
		In.	mm	Cat 6A (0.300")	Cat 6 (0.240")	Cat 5e (0.225")	
Wall Mount							
JP75W-L20	J Hook for wall mount applications. One 1/4" (M6) mounting hole for user supplied screw. Not for use with powder actuated fasteners.	0.75	19.0	5	8	10	50
JP131W-L20		1.31	33.3	15	25	29	50
JP2W-L20		2.00	50.8	30	46	55	50
JP4W-X20		4.00	101.6	115	180	200	10
Wall Mount with Bracket							
JP75WP2-L20	J Hook for powder actuated installation on walls. One 5/32" (M4) mounting hole and one 1/4" (M6) mounting hole for user supplied fasteners.	0.75	19.0	5	8	10	50
JP131WP2-L20		1.31	33.3	15	25	29	50
JP2WP2-L20		2.00	50.8	30	46	55	50
JP4WP2-X20		4.00	101.6	115	180	200	10
Ceiling Mount							
JP75CM-L20	J Hook with ceiling mount bracket that has one 3/16" (M5), 1/4" (M6), and 3/8" (M10) mounting hole.	0.75	19.0	5	8	10	50
JP131CM-L20		1.31	33.3	15	25	29	50
JP2CM-L20		2.00	50.8	30	46	55	50
JP4CM-X20		4.00	101.6	115	180	200	10
Drop Wire and Threaded Rod Clip							
JP75DW-L20	J Hook with clip for use with #12 wire, threaded rod up to 3/8" (9.5mm) in diameter.	0.75	19.0	5	8	10	50
JP131DW-L20		1.31	33.3	15	25	29	50
JP2DW-L20		2.00	50.8	30	46	55	50

Suitable for use in air handling spaces in accordance with Sec. 300-22(c) and (d) of the National Electrical Code. JP4 family of parts suitable for use in single unit configurations. Listed in accordance with CAN/ULC S102.2 when mounted as single units or in pairs. Minimum spacing of 4 feet (1220mm) required between mount points. (Flame spread rating = 0, Smoke developed classification = 30). All dimensions represent typical outer cable diameter in inches (mm).





J-Pro™ Cable Support System (continued)



JP2SBC50-L20



JP2SBC50R-L20



JP2SBC87-L20



JP2SBC87R-L20



JP2HBC25R-L20

JP2HBC50R-L20

JP2HBC75R-L20

Part Number	Part Description	Max. Bundle Capacity		Max. Cable Capacity			Std. Pkg. Qty.
		In.	mm	Cat 6A (0.300")	Cat 6 (0.240")	Cat 5e (0.225")	
Screw-On Beam Clamps							
JP75SBC50-L20	J Hook with screw-on beam clamp for use with flanges up to 1/2" (12.7mm) thick. Non-rotating mount.	0.75	19.0	5	8	10	50
JP131SBC50-L20		1.31	33.3	15	25	29	50
JP2SBC50-L20		2.00	50.8	30	46	55	50
JP4SBC50-X20		4.00	101.6	115	180	200	10
JP75SBC50R-L20	J Hook with screw-on beam clamp for use with flanges up to 1/2" (12.7mm) thick. Rotates 360 degrees.	0.75	19.0	5	8	10	50
JP131SBC50R-L20		1.31	33.3	15	25	29	50
JP2SBC50R-L20		2.00	50.8	30	46	55	50
JP4SBC50R-X20		4.00	101.6	115	180	200	10
JP75SBC87-L20	J Hook with screw-on beam clamp for use with flanges up to 3/4" (19.1mm) thick. Non-rotating mount.	0.75	19.0	5	8	10	50
JP131SBC87-L20		1.31	33.3	15	25	29	50
JP2SBC87-L20		2.00	50.8	30	46	55	50
JP4SBC87-X20		4.00	101.6	115	180	200	10
JP75SBC87R-L20	J Hook with screw-on beam clamp for use with flanges up to 3/4" (19.1mm) thick. Rotates 360 degrees.	0.75	19.0	5	8	10	50
JP131SBC87R-L20		1.31	33.3	15	25	29	50
JP2SBC87R-L20		2.00	50.8	30	46	55	50
JP4SBC87R-X20		4.00	101.6	115	180	200	10
Hammer-On Beam Clamps							
JP75HBC25R-L20	J Hook with hammer-on beam clamp for use with flanges 1/8" – 1/4" (3.2mm – 6.4mm) thick. Rotates 360 degrees.	0.75	19.0	5	8	10	50
JP131HBC25R-L20		1.31	33.3	15	25	29	50
JP2HBC25R-L20		2.00	50.8	30	46	55	50
JP4HBC25R-X20		4.00	101.6	115	180	200	10
JP75HBC50R-L20	J Hook with hammer-on beam clamp for use with flanges 5/16" – 1/2" (7.9mm – 12.7mm) thick. Rotates 360 degrees.	0.75	19.0	5	8	10	50
JP131HBC50R-L20		1.31	33.3	15	25	29	50
JP2HBC50R-L20		2.00	50.8	30	46	55	50
JP4HBC50R-X20		4.00	101.6	115	180	200	10
JP75HBC75R-L20	J Hook with hammer-on beam clamp for use with flanges 9/16" – 3/4" (14.3mm – 19.1mm) thick. Rotates 360 degrees.	0.75	19.0	5	8	10	50
JP131HBC75R-L20		1.31	33.3	15	25	29	50
JP2HBC75R-L20		2.00	50.8	30	46	55	50
JP4HBC75R-X20		4.00	101.6	115	180	200	10

Suitable for use in air handling spaces in accordance with Sec. 300-22(c) and (d) of the National Electrical Code. JP4 family of parts suitable for use in single unit configurations. Listed in accordance with CAN/ULC S102.2 when mounted as single units or in pairs. Minimum spacing of 4 feet (1220mm) required between mount points. (Flame spread rating = 0, Smoke developed classification = 30). All dimensions represent typical outer cable diameter in inches (mm).

Table continues on page L.94



J-Pro™ Cable Support System (continued)



JP2ZP-L20



JP2CP-L20



JP2UF100-L20

Part Number	Part Description	Max. Bundle Capacity		Max. Cable Capacity			Std. Pkg. Qty.
		In.	mm	Cat 6A (0.300")	Cat 6 (0.240")	Cat 5e (0.225")	
Z-Purlin Clips							
JP75ZP-L20	J Hook with z-purlin clip for use with angled flanges up to 1/4" (6.4mm) thick.	0.75	19.0	5	8	10	50
JP131ZP-L20		1.31	33.3	15	25	29	50
JP2ZP-L20		2.00	50.8	30	46	55	50
JP4ZP-X20		4.00	101.6	115	180	200	10
C-Purlin Clips							
JP75CP-L20	J Hook with c-purlin clip for use with vertical flanges up to 1/4" (6.4mm) thick.	0.75	19.0	5	8	10	50
JP131CP-L20		1.31	33.3	15	25	29	50
JP2CP-L20		2.00	50.8	30	46	55	50
JP4CP-X20		4.00	101.6	115	180	200	10
Underfloor Pedestal Support Clamp							
JP75UF100-L20	J Hook with underfloor clamp for use with pedestal support 7/8" square or 1 1/8" – 1 3/8" in diameter.	0.75	19.0	5	8	10	50
JP131UF100-L20		1.31	33.3	15	25	29	50
JP2UF100-L20		2.00	50.8	30	46	55	50
JP4UF100-X20		4.00	101.6	115	180	200	10

Suitable for use in air handling spaces in accordance with Sec. 300-22(c) and (d) of the National Electrical Code. JP4 family of parts suitable for use in single unit configurations. Listed in accordance with CAN/ULC S102.2 when mounted as single units or in pairs. Minimum spacing of 4 feet (1220mm) required between mount points. (Flame spread rating = 0, Smoke developed classification = 30). All dimensions represent typical outer cable diameter in inches (mm).

Metal Stud Grommets and Accessories

- Metal stud grommets and cable support manager support and protect cable within the building structure
- Metal Stud Punching Tool punches a 1-11/32" (34.1mm) round hole in 25 GA. min. to 20 GA max. mild steel studs; contoured handle; lightweight aluminum head; automatic hole centering on standard width (3.625") studs; replaceable punch and dies; self-stripping design that eliminates punch hang-ups



MSG-1.3-C



MSGV-1.3-C



MSPT-1.3



CSM-1.25-C

Part Number	Part Description	Std. Pkg. Qty.	Std. Ctn. Qty.
MSG-1.3-C	Metal stud grommet, 1-11/32" hole.	100	1000
MSGV-1.3-C	Metal stud grommet, 1-11/32" hole, anti-vibration for 1/2" to 1" pipe.	100	1000
MSPT-1.3	Metal stud punch tool with contoured handle for increased leverage.	1	0
CSM-1.25-C	Cable stud manager for 1.25" cable spacing.	100	1000

Color Option Chart

Base Part Number	Black	Red	Blue	White	Green	Orange
JP75W	-L20	-L2			-L5	-L3
JP75WP2	-L20					
JP75CM	-L20	-L2				
JP75DW	-L20	-L2	-L6			
JP75ZP	-L20					
JP75CP	-L20					
JP75SBC50	-L20					
JP75SBC87	-L20					
JP75SBC50R	-L20	-L2		-L		
JP75SBC87R	-L20					
JP75HBC25R	-L20					
JP75HBC50R	-L20	-L2		-L		
JP75HBC75R	-L20					
JP75UF100	-L20					
JP131W	-L20		-L6		-L5	-L3
JP131WP2	-L20					
JP131CM	-L20					
JP131DW	-L20		-L6			
JP131ZP	-L20					
JP131CP	-L20					
JP131SBC50	-L20					
JP131SBC87	-L20					
JP131SBC50R	-L20	-L2		-L		
JP131SBC87R	-L20					
JP131HBC25R	-L20					
JP131HBC50R	-L20	-L2		-L		
JP131HBC75R	-L20					
JP131UF100	-L20					
JP2W	-L20	-L2	-L6	-L	-L5	-L3
JP2WP2	-L20					
JP2CM	-L20	-L2				
JP2DW	-L20	-L2	-L6	-L		
JP2ZP	-L20					
JP2CP	-L20					
JP2SBC50	-L20			-L		
JP2SBC87	-L20					
JP2SBC50R	-L20	-L2		-L		
JP2SBC87R	-L20	-L2				
JP2HBC25R	-L20					
JP2HBC50R	-L20	-L2		-L		
JP2HBC75R	-L20					
JP2UF100	-L20					
JP4W	-X20	-X2	-X6	-X		
JP4WP2	-X20					
JP4CM	-X20					
JP4ZP	-X20					
JP4CP	-X20					
JP4SBC50	-X20			-X		
JP4SBC87	-X20					
JP4SBC50R	-X20	-X2		-X		
JP4SBC87R	-X20					
JP4HBC25R	-X20					
JP4HBC50R	-X20	-X2		-X		
JP4HBC75R	-X20					
JP4UF100	-X20					

cUL[®] LISTED PATENTED J-Mod[®] Cable Support System

- Complete horizontal and vertical 1" (25.4mm) bend radius control
- Manufactured from materials that meet UL 2043 and are suitable for use in air handling spaces
- Brackets allow for attachment to ceilings, beams, threaded rods, and drop wires to meet requirements of a variety of applications
- Cables do not come in contact with metal
- Modular design allows flexibility to assemble system in multiple configurations
- Unique chaining bracket design creates a strong metal backbone and allows expansion of the system without disturbance of an existing installation

Typical Installation Instructions Using Threaded Rod Bracket and Chaining Bracket



Align snap lock attachment of J Hook with holes in chosen bracket and snap J Hook into place



Align chaining bracket under the assembly



Slide chaining bracket between J Hook and the metal bracket until it snaps



Pull down to fully engage



Attach J Hooks as explained in first-level installation above



Final assembly is a second-level installation consisting of one threaded rod bracket, one chaining bracket, and two J Hooks for clarity



J-Mod® Cable Support System (continued)



JMJH2W-X20



JMJH2-X20



JMCB-X



JMCMB25-1-X



JMCMB25-3-X



JMDWB-1-X



JMDWB-3-X



JMTRB38-1-X



JMTRB38-3-X



JMSBCB87-1-X



JMSBCB87-3-X

Part Number	Part Description	Material*	Std. Pkg. Qty.	Std. Ctn. Qty.
J Hook with Maximum 2" Bundle Capacity				
JMJH2W-X20	J Hook for wall mount applications only. Two 1/4" (M6) mounting holes for user supplied screws.	Nylon 6.6	10	50
JMJH2-X20	J Hook with snap lock attachments for use with all brackets listed below.	Nylon 6.6	10	50

Chaining Bracket

JMCB-X	Chaining bracket to extend J-Mod® capacity one level. Capacity: three levels maximum. For use with all single-level mounting brackets listed below.	Zinc Plated Steel	10	50
--------	---	-------------------	----	----

Ceiling Mount Brackets

JMCMB25-1-X	Single-level ceiling mount bracket with one 1/4" (M6) mounting hole.	Galvanized Steel	10	50
JMCMB25-3-X**	Three-level ceiling mount bracket with one 1/4" (M6) mounting hole. Maximum capacity of six J Hooks.	Galvanized Steel	10	50

Drop Wire Brackets

JMDWB-1-X	Single-level drop wire bracket. Attaches to #12 wire or 3/8" (9.5mm) threaded rod. Maximum capacity of one J Hook per level.	Galvanized Steel with Metal Attachments	10	50
JMDWB-3-X**	Three-level drop wire bracket. Attaches to #12 wire or 3/8" (9.5mm) threaded rod. Maximum capacity of one J Hook for each of three levels. Maximum static load of 40 pounds.	Galvanized Steel with Metal Attachments	10	50

Threaded Rod Brackets

JMTRB38-1-X	Single-level threaded rod bracket. Accepts 1/4" – 3/8" (6.4mm – 9.5mm) threaded rod.	Galvanized Steel with Metal Attachments	10	50
JMTRB38-3-X**	Three-level threaded rod bracket. Accepts 1/4" – 3/8" (6.4mm – 9.5mm) threaded rod. Maximum capacity of six J Hooks.	Galvanized Steel with Metal Attachments	10	50

Screw-On Beam Clamp Brackets

JMSBCB87-1-X	Single-level screw-on beam clamp bracket for use with flanges up to 3/4" (19.1mm) thick.	Galvanized Steel with Metal Attachments	10	50
JMSBCB87-3-X**	Three-level screw-on beam clamp bracket for use with flanges up to 3/4" (19.1mm) thick. Maximum capacity of six J Hooks.	Galvanized Steel with Metal Attachments	10	50

*Suitable for use in air handling spaces and listed in accordance with UL 2043 and CAN/ULC S102.2 when mounted as single units or in pairs. Maximum spacing of 4' (1220mm) required between mount points. (Flame Spread Rating = 0, Smoke Developed Classification = 30).

**Not for use with chaining brackets.

	Maximum Cable Capacity		
	Cat 6A (0.300")	Cat 6 (0.240")	Cat 5e (0.225")
JMJH2W or JM JH2	30	46	55



PATENTED Conduit Waterfall

- Helps prevent pinch points and over bending that could cause damage to cable
- Suitable for use in air handling spaces per UL 2043
- UL listed per UL 1565
- Able to manage and support a large capacity of cables
- Easy and fast to install reducing labor cost

- Unique patented design allows for use in both new and retrofit applications
- Allows user to install 3/4" (19.1mm) Tak-Ty® Cable Ties to provide a method to retain and manage the cable bundle
- Material: Black Glass-Filled Nylon 6.6 which meets UL 94V-0 specifications



Part Number	Part Description	Std. Pkg. Qty.	Std. Ctn. Qty.
CWF400	Provides bend radius control for cables entering/exiting 4" (101.6mm) EMT conduit. Secure to conduit without tools utilizing integral thumb screw and captive nut.	1	10

Waterfall Accessories

- Patented bend radius control product for standard ladder rack
- Product available as a kit (includes base, two wings, and cable ties) or purchased separately
- Easy to install waterfall kit maintains bend radius control in both vertical and horizontal directions to provide a standards-compliant installation

- Base attaches to either the rung or stringer on most standard ladder racks for a variety of installations/configurations
- Modular components allow user to custom configure each location where cable management is required
- Material: Black Glass-Filled Nylon 6.6 which meets UL 94V-0 specifications



CMW-KIT

Part Number	Part Description	Std. Pkg. Qty.	Std. Ctn. Qty.
CMW-KIT*	Cable management waterfall kit. Provides bend radius control when transferring cables from standard ladder rack. Kit includes CMWB, two CMWW, and cable ties.	1	10
CMWB*	Cable management waterfall base. Used to maintain 1.75" (44.5mm) bend radius control vertically when transferring cable off of ladder rack. Mounts to ladder rack rung or stringer with standard cross section cable ties (included).	1	10
CMWW*	Cable management waterfall wing. Used in conjunction with CMWB to maintain 1.00" (25.4mm) bend radius control horizontally when transferring cable off ladder rack.	1	10

*Available in natural (white). Add 10 to part number suffix. For example: CMW-KIT10.



CMWB



CMWW

Double Waterfall Accessory

- Double waterfall base attaches to the rung on most standard ladder racks to allow bend radius control for cables coming from either direction
- Easy to install double waterfall base maintains bend radius control in a vertical direction to provide a standards-compliant installation
- Material: Black Glass-Filled Nylon 6.6 which meets UL 94V-0 specifications



Part Number	Part Description	Std. Pkg. Qty.	Std. Ctn. Qty.
CMW2B	Cable management double waterfall base. Used to maintain 1.75" (101.6mm) bend radius control vertically when transferring cable off either side of ladder rack rung. Mounts to ladder rack rung with standard cross section cable ties (included).	1	10

Threaded Rod Cover

- Protects cable from abrasion caused by contact with threaded rod
- Available in 18" (457mm) lengths
- Accepts 1/2" to 5/8" (12.7mm to 15.9mm) threaded rod
- For indoor use only
- Material: Flame Retardant Polyethylene which meets UL 94V-0 specifications



Part Number	Part Description	Std. Pkg. Qty.	Std. Ctn. Qty.
TRC18FR-X8Y	Used to protect cabling from threaded rod. Vertical slit allows easy installation. Gray.	10	100
TRC18FR-X20Y	Used to protect cabling from threaded rod. Vertical slit allows easy installation. Black.	10	100

PATENTED Stackable Cable Rack Spacers

- Patented accessories for standard ladder racks
- Separate and support cable and prevent pinch points between the bottom row of cable and the rung as a result of the weight of multiple cable layers applied on top of each other
- Mount to ladder rack with standard cross section cable ties
- Maximize rack space by stacking products for maximum cable capacity
- Provide an alternative to lacing cord by allowing user to secure cable to spacer to prevent movement of cable

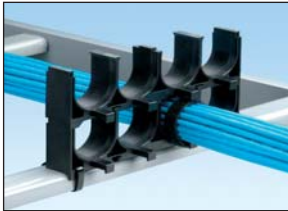

CRS4-125-X



CRS1-125-X



CRS6-X



CRS1-X

Part Number	Part Description	Width		Std. Pkg. Qty.	Std. Ctn. Qty.
		In.	mm		
CRS4-125-X	Four space stackable cable rack spacer. Manufactured from black glass-filled flame retardant nylon 6.6. Accepts cable up to 1.25" (31.8mm) diameter.	5.24	133.1	10	100
CRS1-125-X	One space stackable cable rack spacer. Manufactured from black glass-filled flame retardant nylon 6.6. Use with CRS4 to fill width of ladder rack. Accepts cable up to 1.25" (31.8mm) diameter.	1.55	39.4	10	100
CRS6-X	Six space stackable cable rack spacer. Manufactured from black polycarbonate ABS blend. Accepts cable up to .80" (20.3mm) diameter.	5.25	133.4	10	100
CRS1-X	One space stackable cable rack spacer. Manufactured from black polycarbonate ABS blend. Use with CRS6 to fill width of ladder rack. Accepts cable up to .80" (20.3mm) diameter.	1.13	28.58	10	100

Part Number	Maximum Cable Capacity		
	Cat.6A (0.300")	Cat.6 (0.240")	Cat.5e (0.225")
CRS4-125-X	10	15	17
CRS1-125-X	5	7	8