

# POP<sup>®</sup>

## INSTRUCTION MANUAL PRG 540

### Pneumatic Blind Rivet Tool



**EMHART<sup>®</sup>**  
**TEKNOLOGIES**

# PRG 540 AIR-HYDRAULIC POP RIVET TOOL

## SECTION I—GENERAL INFORMATION

The PRG 540 is an Air-Hydraulic tool suitable for setting all "POP" Rivets up to and including 1/4" Monel Rivets. The PRG 540 is equipped to handle various Nosepieces (See Table 1, page 8, for specific sizes available). The main castings are made of high tensile aluminum, and replacement parts are interchangeable.

### DATA

Weight of tool .....	4½ lbs. (approx.)
Centerline of Nosepiece to top of tool .....	1 in.
Length including Deflector .....	9 in. (approx.)
Length with Deflector collapsed .....	7½ in. (approx.)
Stroke .....	11/16 in.
Hydraulic Oil .....	PRG540-130 (Consult Table II, Page 8, for commercial equivalent)
Air Pressure .....	85 PSIG (5.8 BAR) Max.

## SECTION II—OPERATION

The following description gives a brief summary of the events that follow when the Trigger is depressed.

1. When Trigger PRG 540-101 is squeezed, Valve PRG 540-36 is moved down off its seat, allowing air to flow up Valve Sleeve PRG 540-32.
2. Air flows through supply hole of PRG 540-32 into bottom of Intensifier Chamber PRG 540-29 to force Air Piston PRG 540-27 up.
3. As Air Piston PRG 540-27 moves up, Ram PRG 540-24 forces Hydraulic Fluid into upper cylinder to act on Hydraulic Piston PRG 540-12.
4. As Hydraulic Piston PRG 540-12 moves rearward, Jaws PRG 540-46 grip Mandrel of the Rivet and pull it until Rivet is set.

5. When Trigger PRG 540-101 is released, Valve PRG 540-36 resets and shuts off air supply. Exhaust Tube PRG 540-33 lifts off Valve PRG 540-36 and allows the air to flow up Exhaust Tube PRG 540-33.

6. Jaws PRG 540-46, Jaw Guide PRG 740-11A and Hydraulic Piston PRG 540-12 are returned to normal position by the Return Spring PRG 540-104. This opens Jaws PRG 540-46 and releases the broken mandrel.

7. As Hydraulic Piston PRG 540-12 returns, it forces oil back through Ram Sleeve PRG 540-5 which in turn returns Ram PRG 540-24 and Air Piston PRG 540-27 to their normal position.

## SECTION III—CARE AND MAINTENANCE

### A. GENERAL

For greater efficiency and prolonged life from this tool, a regular service procedure should be established and maintained. This procedure should be carried out daily, prior to operating the tool.

The following points should be checked.

1. Check connection between Pulling Head Adapter PRG 540-21 and Piston Rod PRG 540-14 for tightness.
2. Clean Jaws PRG 540-46, Jaw Guide PRG 740-11A, and Jaw Pusher PRG-14 by following the procedure outlined as follows:
  - a. Remove Nose Housing PRG 540-22 along with Nosepiece.
  - b. Remove Jaw Guide PRG 740-11A, Jaws PRG 540-46, Jaw Pusher PRG-14 and Jaw Pusher Spring PRG 540-105.
  - c. Clean Jaw Guide, Jaw Pusher, Jaws and Spring. Clean serrations in Jaws with a wire brush.
  - d. Apply a light machine oil to Mandrel Guide, Jaw Pusher, and on the tapered faces of the Jaws.

### NOTE

For alternate method of cleaning and lubricating tool, use Jaw Lube PRG 510-130 following directions on container. Disassembly of the tool is NOT required.

e. Reassemble and cycle a few times to check operation before using.

3. Make sure Nose Housing PRG 540-22 and Nosepiece PRN are securely fastened.

### B. HYDRAULIC FLUID REPLACEMENT

#### 1. MINOR HYDRAULIC FLUID LOSS

Be sure that tool is making a full and normal stroke to the rear, such that the head of the Hydraulic Piston PRG 540-12 is aligned approximately with the rear of Handle PRG 540-31. Eventually there may be a gradual loss or leakage of enough oil to cause a shortening of the stroke. This shortening will vary with the individual tools due to the number and size of Rivets being set, but will, on the average, occur after more than 50,000 Rivets have been set. When this condition eventually occurs, proceed as follows:

- a. Disconnect tool from air supply.
- b. Remove Nosepiece PRN and Fill Screw PRG 540-122.
- c. Screw a 3/8"-24 Screw (approx. 1 inch long) in place of Nosepiece PRN until Hydraulic Piston PRG 540-12 is moved approx. 1/4" to the rear.

## CAUTION

Do not turn this screw in far enough to force Hydraulic Piston to the end of its normal stroke.

d. Add PRG540-130 Hydraulic Fluid through Fill Screw hole a drop at a time, so that Fill Screw hole does not get "plugged" with oil.

## NOTE

Care should be taken to allow the air bubbles to rise out of the oil.

e. Insert Fill Screw PRG 540-122 and new Fill Washer PRG 540-102. Tighten securely.

f. Remove 3/8-24 screw. Reconnect air supply and cycle tool several times. Disconnect air supply again.

g. Loosen Fill Screw PRG 540-122 slightly to allow excess oil to be forced out and to return Hydraulic Piston PRG 540-12 to its normal position. Visually inspect tool to see if Jaw Guide PRG 740-11A is seated against inside of Nose Housing PRG 540-22.

h. Replace Nosepiece PRN and tighten securely.

## NOTE

In some cases where the tool has been operated for some time without sufficient oil, a foam of oil may flow out when Fill Screw PRG 540-122 is loosened or removed. If practical, allow tool to stand upright for an hour or more to allow this foam to settle and then follow the above steps for filling. If tool must be used immediately, follow the above steps for filling but push the Hydraulic Piston PRG 540-12 back about 1/2 inch with the 3/8-24 screw to replace more of the foamed oil. It is desirable, but not essential that all of the oil foam be eliminated.

## 2. Major Hydraulic Fluid Loss

If the tool has had major fluid loss, as will occur in repairs to the Restrictor Housing Seal PRG 540-4 or Ram Sleeve PRG 540-5, replace the Hydraulic Fluid as follows:

## NOTE

Handle assembly must be assembled including all internal parts as well as the Jaw pulling mechanism, Nose Housing, Fill Screw and Seal, Air Line, Valve and Sleeve Retainer Plate before adding Hydraulic Fluid. DO NOT put Ram into Ram Sleeve at this point.

a. While holding Handle Assembly upside down in a vise, fill Ram Sleeve to within 1/4" of top with Hydraulic Fluid PRG540-130 or equivalent.

b. Thread a 3/8-24 screw (approx. 1" long) in place of the Nosepiece PRN until Hydraulic Piston assembly is moved approximately 5/8" to the rear.

c. Unscrew the 3/8-24 screw slowly and stop turning when oil level in Ram Sleeve stops rising.

## NOTE

As the oil has now displaced air in the piston chamber, the oil level will be considerably lower.

d. Repeat steps a. through c. above and observe that all air has been removed from system by noting air bubbles rising in oil.

e. If air is still being expelled, repeat steps b. and c.

f. After all air has been eliminated and the oil level is maintained to within 1/4" from top of sleeve (push Hydraulic Piston Rod to insure its full return to forward position), carefully insert Ram and Air Piston assembly into Ram Sleeve.

g. Push Ram half-way down and while holding in this position, thread in the 3/8-24 screw until resistance is felt.

## NOTE

At this point the Ram will be mechanically held in the partially compressed position, facilitating completion of assembly.

h. Replace Intensifier Chamber PRG 540-29 over Air Piston and locate in place on Pins. Holding the two sections together, invert assembly to upright position in vise. Secure in place with eight Intensifier Chamber Screws PRG 540-123 and eight Lock Washers PRG 540-120.

i. Remove excess oil and complete assembly following steps in Section III, para. B1 f-h.

## C. AIR LINE REPLACEMENT

If the Air Line PRG 540-39 becomes damaged, repair or replace it by the following procedure:

1. Remove Air Line "O" Clamp PRG 540-45 by cutting or deforming the two ears.
2. Remove Air Line from Air Line Fitting PRG 540-38. Cut Air Line back beyond damaged area or replace with new Air Line.
3. Place new Clamp PRG 540-45 on Air Line.
4. Insert new or repaired line over Air Line Fitting.

## NOTE

Dipping Air Line in hot water will facilitate insertion onto Air Line Fitting.

4. Tighten new Clamp PRG 540-45 in place by squeezing with pliers on both ears.

---

## SECTION IV—DISASSEMBLY AND ASSEMBLY

### A. GENERAL

In assembling or disassembling this tool, care should be taken that foreign matter does not get into the oil and air seals of the tool. When ordering replacement parts, order by part number shown on page 10.

### CAUTION

Shut off air supply to the tool before proceeding with any assembly or disassembly procedures.

### IMPORTANT

Lubricate ALL Seals and Seal surfaces before installation.

## B. AIR PISTON AND AIR PISTON SEAL

### NOTE

To assist in tool disassembly, follow steps in Section III, par. B1, a-c, threading the  $\frac{3}{8}$ -24 screw in  $\frac{1}{2}$ ".

#### 1. Disassembly

- a. Unscrew eight Intensifier Chamber Screws PRG 540-123 and remove Lock Washers PRG 540-120.
- b. Remove Intensifier Chamber PRG 540-29. This can be facilitated by tipping Chamber in order for it to slide more easily on the Air Piston Seal.
- c. Remove Air Piston PRG 540-27 and remove Air Piston Retainer PRG 540-19 from Ram PRG 540-24 if it is to be replaced.
- d. Remove Air Piston Block PRG 540-28 from Air Piston.

#### 2. Assembly

- a. Insert Air Piston Block PRG 540-28 into groove provided in Air Piston PRG 540-27. Groove of seal faces away from beveled edge of Air Piston PRG 540-27.
- b. Insert Air Piston Retainer PRG 540-119 into groove provided in end of Ram 540-24.
- c. Press Air Piston PRG 540-27 in place on end of Ram PRG 540-24.
- d. Coat inside of Intensifier Chamber PRG 540-29 with a light film of Lubriplate 130AA or equivalent.
- e. Check to see that Intensifier Chamber Seal PRG 540-118 is in place in Sleeve Retainer Plate PRG 540-7A.
- f. Place Intensifier Chamber PRG 540-29 in place over Air Piston PRG 540-27 and secure with eight Intensifier Chamber Screws PRG 540-123 and Lock Washers PRG 540-120. Check location of two Dowel Pins PRG 540-106 when positioning Intensifier Chamber PRG 540-29.

## C. RAM AND RAM SEALS

#### 1. Disassembly

- a. Remove Intensifier Chamber. See Section IV, par. B1, a and b.
- b. Remove Air Piston PRG 540-27 and Ram PRG 540-24 from Handle PRG 540-31.

### NOTE

Stand tool upside down to prevent oil from running out of Ram Sleeve when Ram is removed.

- c. Unscrew Ram Screw PRG 540-100 from Ram PRG 540-24 and remove Lockwasher PRG 540-120 Ram Seal Retaining Washer PRG 540-113, Ram Seal PRG 540-26A and Ram Seal Backup Ring PRG 540-25.

#### 2. Assembly

- a. Place Ram Seal Backup Ring PRG 540-25 and Ram Seal (flat side down) PRG 540-26A on tapped end of Ram PRG 540-24 in that order.
- b. Place Ram Seal Retaining Washer PRG 540-113 and Lock Washer PRG 540-120 on Ram PRG 540-24 and secure with Ram Screw PRG 540-100.
- c. Insert Ram and Air Piston assembly into Ram Sleeve PRG 540-5. Care should be taken not to damage Ram Seal.
- d. Replace Intensifier Chamber PRG 540-29 per Section IV, par. B2, d-f.
- e. Recharge tool with hydraulic oil per Section III, par. B1.

## D. RAM SLEEVE AND RESTRICTOR HOUSING SEAL

#### 1. Disassembly

- a. Remove Ram PRG 540-24 per Section IV, par. C1, a and b. Pour out Hydraulic Fluid from Ram Sleeve.
- b. Remove three Retainer Plate Screws PRG 520-100 and Lock Washers PRG 540-120. Sleeve Retainer Plate PRG 540-7A and Intensifier Chamber Seal PRG 540-118.
- c. Remove Ram Sleeve PRG 540-5 taking care not to scratch or score polished inside surface of Sleeve.
- d. Remove Restrictor Housing PRG 540-3, Restrictor Seat PRG 540-112, Restrictor PRG 540-2 and Restrictor Housing Seal PRG 540-4.

### NOTE

If these cannot be jarred loose for removal, then remove Hydraulic Piston Rod and Seal Sleeve Assemblies and push them out with a rod through the Fill Screw hole.

#### 2. Assembly

- a. Place Restrictor Housing Seal PRG 540-4 on Restrictor Housing PRG 540-3 and place assembly on **squared** end of Ram Sleeve PRG 540-5.
- b. Place Restrictor PRG 540-2 in recess of Restrictor Housing.
- c. Apply Lubriplate 130AA or equivalent sparingly to outer surface of Restrictor Housing Seal PRG 540-4 and the top outer edge of the Restrictor Housing PRG 540-3. Place Restrictor Seat PRG 540-112 on top of Restrictor Housing and push down firmly.

### NOTE

The surface tension of the Lubriplate 130AA will aid to keep the Restrictor Seat in place during insertion into the Handle Assembly.

- d. Turn Handle Assembly PRG 540-31 upright and using finger tips as a guide, carefully insert Ram Sleeve assembly upward into Handle until Restrictor Housing is seated in place. When properly installed, the Ram Sleeve PRG 540-5 should protrude no more than .050 of an inch from bottom of Handle.
- e. Install new Sleeve Retainer Plate PRG 540-7A and secure with three Retainer Plate Screws PRG 520-100 and Lock Washers PRG 540-120.
- f. Reassemble tool per Section III, par. B2.

## E. AIR VALVE

#### 1. Disassembly

- a. Remove Sleeve Retainer Plate per Section IV, par. D1, a and b, including removal of Hydraulic Fluid from Ram Sleeve.
- b. Remove Valve Plug PRG 540-35, Valve Plug Seal PRG 540-115, Valve PRG 540-36 and Trigger Return Spring PRG 545-3.

To aid in removal of Valve Plug, **hold hand over plug and carefully** blow out parts with short air burst from nozzle held at end of air line.

## 2. Assembly

- a. Insert Trigger Return Spring PRG 545-3 into Exhaust Tube PRG 540-33.
- b. Insert Valve PRG 540-36 into Valve Sleeve PRG 540-32.
- c. Assemble Valve Plug Seal PRG 540-115 and Valve Plug PRG 540-35 together and place in Handle PRG 540-31.
- d. Replace Sleeve Retainer Plate per Section IV, par. D2, e.
- e. To complete assembly see Section III, par. B2.

## F. TRIGGER AND EXHAUST TUBE

### 1. Disassembly

- a. Remove Valve Assembly per Section IV, par. E1.
- b. Remove Ram Sleeve per Section IV, par. D1, c, being sure not to disturb Restrictor Housing PRG 540-3 or Restrictor Housing Seal PRG 540-4.
- c. Remove Trigger Pin PRG 540-107.
- d. Pull up on Trigger and Exhaust Tube assembly to release Exhaust Tube from Valve Sleeve. Tilt Handle rearwards and drop Trigger assembly out through Ram Sleeve hole at bottom of Handle casting.
- e. Remove Exhaust Tube Pin PRG 540-106 by filing off one of the peened ends and push pin out.

#### NOTE

Valve Sleeve is assembled and cemented to Handle PRG 540-31 at the factory and is **not** removed during normal servicing of the tool.

- f. Remove Toggle Pin PRG 520A-4 and Trigger PRG 540-101 from Toggle PRG 540-34.

#### NOTE

To prevent breakage of the toggle ears, wedge apart with metal object such as an Allen wrench ( $\frac{7}{32}$ " ) before driving out toggle pin.

### 2. Assembly

- a. Connect Toggle PRG 540-34 and Exhaust Tube PRG 540-33 with Exhaust Tube Pin PRG 540-106. Peen over pin on both ends.

#### NOTE

In peening Pin, DO NOT restrict free movement of parts.

- b. Connect Trigger PRG 540-101 and Toggle PRG 540-34 with Toggle Pin PRG 520A-4. Hold assembly so that end of Toggle Pin is resting on flat metal surface and stake in place (both ends).
- c. Hold Handle assembly horizontal with Trigger port downward and insert assembly Trigger first (flat face pointing down) through Ram Sleeve hole in bottom of Handle casting. Tilt Handle downward allowing Trigger and Toggle to exit through Trigger port.

- d. Holding Trigger, turn Handle upright and insert Exhaust tube into Valve Sleeve. A small rod inserted up through Valve Sleeve and into Exhaust Tube will aid to guide Tube into place.
- e. Position Trigger PRG 540-101 in place and drive Trigger Pin PRG 540-107 through.
- f. Replace Ram Sleeve PRG 540-5 into Handle, squared end first, making certain Restrictor Housing Seal PRG 540-4 has not been disturbed.
- g. Replace Air Valve Assembly per Section IV, par. E2, a-c.
- h. Recharge tool with Hydraulic Fluid and complete assembly per Section III, par. B2.

#### NOTE

To replace only the Trigger Spring (PRG 545-3) it is not necessary to completely disassemble the Trigger mechanism as described above. To accomplish spring replacement, follow steps outlined in Section IV, par. B1 a, b and c and par. E1 a and b.

## G. JAWS, JAW PUSHER, MANDREL GUIDE AND JAW PUSHER SPRING

### 1. Disassembly

- a. Unscrew Nose Housing PRG 540-22 along with Nosepiece.
- b. Place two wrenches on Jaw Guide PRG 740-11A and Pulling Head Adaptor PRG 540-21 to unscrew Jaw Guide.
- c. Remove Jaws PRG 540-46, Jaw Pusher PRG-14, Mandrel Guide PRG 540-43 and Jaw Pusher Spring PRG 540-105.

### 2. Assembly

- a. Oil Jaw Pusher Spring PRG 540-105 and Mandrel Guide PRG 540-43 lightly and insert into Pulling Head Adaptor PRG 540-21.
- b. Apply light film of Lubriplate 130AA to taper of Jaws PRG 540-46 and drop in place in Jaw Guide PRG 740-11A.
- c. Lightly oil outside of Jaw Pusher PRG 14 and drop in place in Jaw Guide. Attach assembly to Pulling Head Adaptor PRG 540-21 with 20 ft. lbs. torque.
- d. Screw Nose Housing PRG 540-22 and Nosepiece onto Handle PRG 540-31. Tighten to 60 ft. lbs. torque.

#### NOTE

When changing to  $\frac{1}{4}$ " "POP" Rivets, Mandrel Guide PRG 540-43 must be removed and Jaw Pusher PRG 740-7A must be used with Jaws PRG 540-44. Be sure the correct Nosepiece PRN is also interchanged.

## H. PULLING HEAD ADAPTOR, RETURN SPRING AND HYDRAULIC PISTON ROD WIPER

### 1. Disassembly

- a. Remove Nose Housing PRG 540-22 along with Nose-piece.
- b. Remove Jaw Pulling mechanism per Sect. IV, para. G1.
- c. Place Pulling Head Adaptor PRG 540-21 in vise and using a  $\frac{5}{8}$ " (16mm) socket wrench on the rear of Hydraulic Piston Rod PRG 540-14, unscrew assembly.

### CAUTION

Pulling Head Adaptor PRG 540-12 is under spring tension and may fly out when connection is broken in step "c" above.

- d. Remove Return Spring PRG 540-104 and Return Spring Washer PRG 540-110.
- e. Remove Retainer Washer PRG 540-109 and Piston Rod Wiper PRG 540-116.

### 2. Assembly

- a. Replace Piston Rod Wiper PRG 540-116 and Retainer Washer PRG 540-109.
- b. Insert Return Spring Washer PRG 540-110 and Return Spring PRG 540-104 over Pulling Head Adaptor PRG 540-21.
- c. Reassemble Pulling Head Adaptor PRG 540-21 and Hydraulic Piston Rod PRG-14 by placing Pulling Head Adaptor in vise and tighten with a  $\frac{5}{8}$ " (16mm) socket wrench on Hydraulic Piston Rod PRG 540-14. Push assembly together to compress Return Spring by firm pressure exerted on Handle assembly. Tighten to 20 ft. lbs. torque.
- d. Reassemble Jaw Pulling mechanism per section IV, par. G2, observing torque requirement.
- e. Screw Nose Housing PRG 540-22 and Nosepiece onto Handle PRG 540-31. Tighten to 60 ft. lbs. torque.
- f. Add Hydraulic Fluid as needed per Section III, par. B1.

## I. HYDRAULIC PISTONS AND SEALS

### 1. Disassembly

- a. Remove Pulling Head Adaptor PRG 540-21 from Hydraulic Piston Rod PRG 540-14 per Section IV, par. H1.
- b. Remove Fill Screw PRG 540-122 and Fill Washer PRG 540-102 and drain hydraulic oil from tool.
- c. Remove Snap Ring PRG 540-11 and push Piston and Seal Sleeve assembly out through nose end of tool. Pull apart Piston assembly from Seal Sleeve assembly.
- d. Remove Piston Rod Snap Ring PRG 540-125 and Seal Retaining Washer PRG 540-108 from Hydraulic Piston Rod PRG 540-14 and then remove Hydraulic Piston Rod from Hydraulic Piston PRG 540-12.
- e. Remove Wiper PRG 540-126, Piston "O" Ring PRG 540-114 and Piston Seal PRG 540-15 from Hydraulic Piston PRG 540-12.
- f. Remove Rod Seal PRG 540-117 and Rod Seal Retainer PRG 540-13 from Hydraulic Piston Rod PRG 540-14.

### 2. Assembly

- a. Insert Rod Seal Retainer PRG 540-13 and Rod Seal PRG 540-117 onto Hydraulic Piston Rod PRG 540-14.
- b. Place Piston Seal PRG 540-15 on Hydraulic Piston PRG 540-12 with flat side inserted first.
- c. Place Wiper PRG 540-126 and Piston "O" Ring PRG 540-114 in grooves provided in Hydraulic Piston PRG 540-12. Lubricate O-Ring and groove with Lubriplate 130AA prior to assembly.
- d. Slide Hydraulic Piston PRG 540-12 and Seal Retaining Washer PRG 540-108 onto Hydraulic Piston Rod PRG 540-14.
- e. Place Piston Rod Snap Ring PRG 540-125 into groove provided in Hydraulic Piston Rod PRG 540-14.

### NOTE

To prevent damage to seal in subsequent assembly procedures, place a piece of cellophane tape or thin-walled tubing over the threads of Hydraulic Piston Rod PRG 540-14.

- f. Carefully insert threaded end of Hydraulic Piston Rod PRG 540-14 through seals in Seal Sleeve PRG 540-10 and push assemblies completely together.
- g. Lubricate the outside of assembly with Hydraulic Fluid USM 300B or equivalent and insert carefully into nose end of tool until flange is tight against shoulder in Handle PRG 540-31.
- h. Insert Snap Ring PRG 540-11 in groove beyond threaded portion in Handle.
- i. To complete reassembly, follow steps in Section IV, par. H2.

## J. SEAL SLEEVE AND SEALS

### 1. Disassembly

- a. Remove Hydraulic Piston and Seal Sleeve assemblies per Section IV, par. I, a-c.
- b. Remove Sleeve "O" Ring PRG 540-114 from Seal Sleeve PRG 540-10.
- c. Remove Seal Retaining Ring PRG 540-121, Seal Retaining Washer PRG 540-111, and Rod Seal PRG 520-63 from Seal Sleeve PRG 540-10.

### NOTE

To facilitate removal of Rod Seal PRG 520-63, insert threaded portion of Hydraulic Piston Rod PRG 540-14 into front of Seal and pry out. Be careful not to scratch inner portion of Seal Sleeve.

### 2. Assembly

- a. Assemble Rod Seal PRG 520-63 flat side first, Seal Retaining Washer PRG 540-111, and Seal Retaining Ring PRG 540-121 into Seal Sleeve PRG 540-10.
- b. Place Sleeve "O" Ring PRG 540-114 in groove provided in Seal Sleeve PRG 540-10. Lubricate O-Ring and groove with Lubriplate 130AA before assembly.
- c. To complete assembly see Section IV, par. 1, 2, f-i, observing cautionary note.

## SECTION V—TROUBLE SHOOTING

TROUBLE	PROBABLE CAUSE	REMEDY
Jaws slipping on mandrels	Dirt in Jaw Teeth  Worn Jaw Teeth Fatigued Jaw Pusher Spring  Loose Jaw Guide or Pulling Head Adaptor	Clean Jaws. See Section III, par. A2. Replace Jaws. See Section IV, par. G. Replace Jaw Pusher Spring. See Section IV, par. G. Tighten. See Section IV, par. H2.
Shortened stroke	Insufficient oil supply	Add oil. See Section III, par. B1.
Jaws fail to open	Nosepiece loose  Jaws sticking  Excess oil	Tighten  Clean and lubricate  Drain oil. See Section III, par. B.
Slow pulling action	Air Line or air passage plugged   Insufficient air pressure Damaged Air Valve Dirt in Restrictor Orifice	Clean. Check Air Line. See Section III, par. C.  Check air supply. Replace. See Section IV, par. E. Clean. See Section IV, par. D.
Excessive oil leakage:  1. Noted on rear  2. Noted on Return Spring 3. Noted around Chamber joint 4. Noted around Trigger	Damaged or worn Hydraulic Piston Seal  Damaged or worn Sleeve Seals Damaged or worn Ram Seal Damaged or worn Seal <ul style="list-style-type: none"> <li>a. Ram Seal</li> <li>b. Seal Sleeve "O" Ring</li> <li>c. Restrictor Housing Seal</li> </ul>	Replace. See Section IV, par. I. Replace. See Section IV, par. J. Replace. See Section IV, par. C.  Replace. See Section IV, par. C. Replace. See Section IV, par. J. Replace. See Section IV, par. D.

Table I

NOSEPIECE NUMBERS			
RIVET DIA.	OPEN END	CLOSED END STEEL MANDREL	CLOSED END ALUM. MANDREL
3/32	PRN-314		
1/8 or 7/64	PRN-414	PRN-424	PRN-434
5/32	PRN-514	PRN-524	PRN-534
3/16	PRN-614	PRN-624	PRN-634
* 1/4	PRN-811	PRN-822	

Table II

COMMERCIAL EQUIVALENTS FOR PRG 540-130 HYDRAULIC FLUID
<p style="margin: 0;"><b>MOBIL — DTE26</b></p> <p style="margin: 0;"><b>EXXON — NUTO H-68</b></p> <p style="margin: 0;"><b>SHELL — TELLUS 68</b></p> <p style="margin: 0;"><b>TEXACO — RANDO HD-68</b></p>

\*When changing to 1/4" Rivets, PRG 540-43 Mandrel Guide must be removed and PRG 740-7A Jaw Pusher must be used together with PRG 540-44 Jaws.



Request Info

1-800-453-1692

[www.aboveboardelectronics.com](http://www.aboveboardelectronics.com)

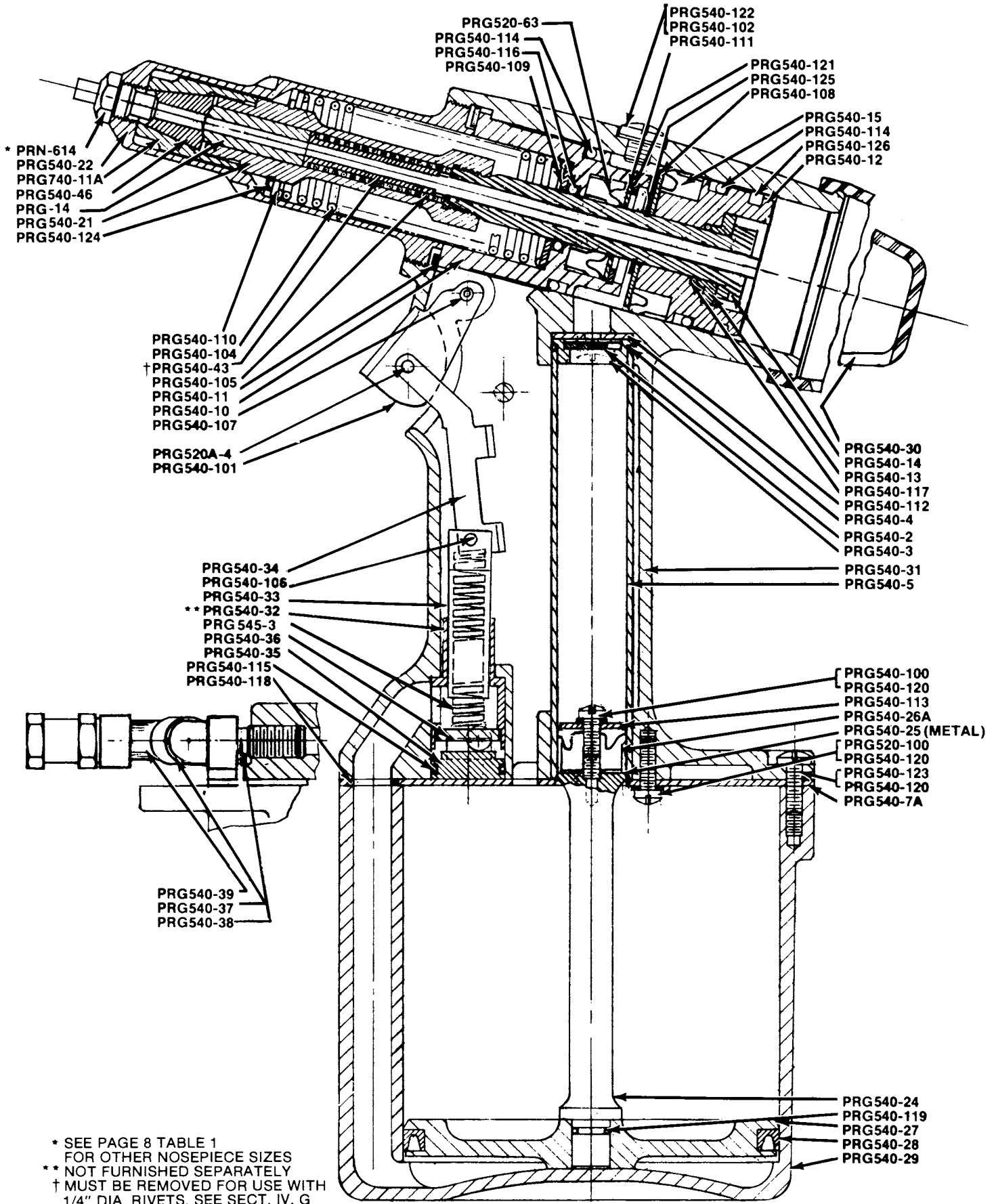

\* PRN-614  
 PRG540-22  
 PRG740-11A  
 PRG540-46  
 PRG-14  
 PRG540-21  
 PRG540-124

PRG520-63  
 PRG540-114  
 PRG540-116  
 PRG540-109

PRG540-122  
 PRG540-102  
 PRG540-111

PRG540-121  
 PRG540-125  
 PRG540-108

PRG540-15  
 PRG540-114  
 PRG540-126  
 PRG540-12

PRG540-110  
 PRG540-104  
 † PRG540-43  
 PRG540-105  
 PRG540-11  
 PRG540-10  
 PRG540-107  
 PRG520A-4  
 PRG540-101

PRG540-34  
 PRG540-106  
 PRG540-33  
 \*\* PRG540-32  
 PRG545-3  
 PRG540-36  
 PRG540-35  
 PRG540-115  
 PRG540-118

PRG540-30  
 PRG540-14  
 PRG540-13  
 PRG540-117  
 PRG540-112  
 PRG540-4  
 PRG540-2  
 PRG540-3  
 PRG540-31  
 PRG540-5

PRG540-100  
 PRG540-120  
 PRG540-113  
 PRG540-26A  
 PRG540-25 (METAL)  
 PRG520-100  
 PRG540-120  
 PRG540-123  
 PRG540-120  
 PRG540-7A

PRG540-39  
 PRG540-37  
 PRG540-38

PRG540-24  
 PRG540-119  
 PRG540-27  
 PRG540-28  
 PRG540-29

\* SEE PAGE 8 TABLE 1  
 FOR OTHER NOSEPIECE SIZES  
 \*\* NOT FURNISHED SEPARATELY  
 † MUST BE REMOVED FOR USE WITH  
 1/4" DIA. RIVETS. SEE SECT. IV, G

PRG540 AIR-HYDRAULIC "POP" RIVET TOOL



# SECTION VI—LIST OF PARTS

PRG 540 NO.	MISC. PARTS	QTY.	PRG 540 NO.	MISC. PARTS	QTY.	
PRG 540-31	HANDLE PARTS	1		JAW, JAW PUSHER AND JAW PUSHER SPRING PARTS		
PRG 540-106		2				
PRG 540-29	Intensifier Chamber	1	* PRN 811	Nosepiece 1/4" Open End	1	
PRG 540-120	Lock Washer	7	* PRN 424	Nosepiece 1/8" Closed End Aluminum Rivet with Steel Mandrel	1	
PRG 540-123	Intensifier Chamber Screw	8	* PRN 524	Nosepiece 5/32" Closed End Aluminum Rivet with Steel Mandrel	1	
PRG 540-38	Air Line Fitting	1	* PRN 624	Nosepiece 3/16" Closed End Aluminum Rivet with Steel Mandrel	1	
PRG 540-39	Air Line	1	* PRN 822	Nosepiece 1/4" Closed End Aluminum Rivet with Steel Mandrel	1	
PRG 540-40	Hose Female Fitting	1	* PRN 434	Nosepiece 1/8" Closed End Aluminum Rivet with Aluminum Mandrel	1	
PRG 540-45	Air Line O-Clamp	4	* PRN 534	Nosepiece 5/32" Closed End Aluminum Rivet with Aluminum Mandrel	1	
PRG 540-37	Air Line Strap, Split	1	* PRN 634	Nosepiece 3/16" Closed End Aluminum Rivet with Aluminum Mandrel	1	
PRG 540-30	Deflector	1		PULLING HEAD ADAPTOR, RETURN SPRING AND PISTON ROD WIPER		
PRG 540-102	Fill Washer	1				
PRG 540-122	Fill Screw	1	PRG 540-21	Pulling Head Adaptor	1	
PRG 540-7A	Sleeve Retainer Plate	1	PRG 540-104	Return Spring	1	
	Retainer Plate Screw	3	PRG 540-110	Return Spring Washer (Front)	1	
PRG 540-120	PRG 520-100	Lock Washer	3	PRG 540-124	Return Spring Snap Ring	1
PRG 540-118		Intensifier Chamber Seal	1	PRG 540-116	Piston Rod Wiper	1
* PRG 540-47	Mandrel Catcher	1	PRG 540-109	Retainer Washer	1	
	AIR PISTON AND SEAL PARTS			HYDRAULIC PISTON AND SEALS		
PRG 540-27	Air Piston	1	PRG 540-14	Hydraulic Piston Rod	1	
PRG 540-28	Air Piston Block	1	PRG 540-12	Hydraulic Piston	1	
PRG 540-119	Air Piston Retainer	1	PRG 540-125	Piston Rod Snap Ring	1	
PRG 540-24	Ram	1	PRG 540-108	Seal Retaining Washer	1	
PRG 540-100	Ram Screw	1	PRG 540-15	Piston Seal	1	
PRG 540-120	Lock Washer	1	PRG 540-126	Wiper	1	
PRG 540-113	Ram Seal Retaining Washer	1	PRG 540-117	Rod Seal (Rear)	1	
PRG 540-25	Ram Seal Backup Ring	1	PRG 540-13	Rod Seal Retainer (Rear)	1	
PRG 540-26A	Ram Seal	1	PRG 540-114	Piston "O" Ring	1	
	RAM SLEEVE AND RESTRICTOR PARTS			SEAL SLEEVE AND SEAL PARTS		
PRG 540-5	Ram Sleeve	1	PRG 540-10	Seal Sleeve	1	
PRG 540-2	Restrictor	1	PRG 540-11	Snap Ring	1	
PRG 540-112	Restrictor Seat	1	PRG 540-114	Sleeve "O" Ring	1	
PRG 540-3	Restrictor Housing	1	PRG 520-63	Rod Seal (Front)	1	
PRG 540-4	Restrictor Housing Seal	1	PRG 540-111	Seal Retaining Washer	1	
	AIR VALVE PARTS		PRG 540-121	Seal Retaining Ring	1	
PRG 540-36	Valve	1	PRG 540-127	Oil Replacement Screw 3/8" -24	1	
PRG 540-35	Valve Plug	1		LUBRICATION		
PRG 540-115	Valve Plug Seal	1		Hydraulic Oil USM 300B		
	TRIGGER AND EXHAUST TUBE PARTS			Lubriplate 130AA		
PRG 540-101	PRG 545-3	Trigger	1	PRG 510-130 Jaw Lube		
PRG 540-107		Trigger Return Spring	1		FOR 1/4" DIA. RIVETS	
PRG 540-34	Trigger Pin	1	PRG 540-44	Jaw 1/4" Rivets	1 pr.	
	PRG 520A-4	Toggle	1	PRG 740-7A	Jaw Pusher	1
PRG 540-33		Toggle Pin	1	PRN-811	Nosepiece 1/4" Rivets	1
PRG 540-33	Exhaust Tube	1	* PRN 822	Nosepiece 1/4" Rivets	1	
PRG 540-106	Exhaust Tube Pin	1				
	JAW, JAW PUSHER AND JAW PUSHER SPRING PARTS					
PRG 540-22	Nose Housing	1				
PRG 540-46	Jaws 3/32" thru 3/16" Rivet	1 set				
	PRG-14	Jaw Pusher	1			
PRG 540-43	Mandrel Guide	1				
PRG 540-105	Jaw Pusher Spring	1				
	PRG740-11A	Jaw Guide	1			
	* PRN 314	Nosepiece 3/32" Open End	1			
	PRN 414	Nosepiece 7/64" and 1/8" Open End	1			
	PRN 514	Nosepiece 5/32" Open End	1			
	PRN 614	Nosepiece 3/16" Open End	1			

When using above parts PRG 540-43 Mandrel Guide must be removed. See Section IV, G

\* Not furnished with tool. Must be ordered separately.



1-800-453-1692

[www.aboveboardelectronics.com](http://www.aboveboardelectronics.com)

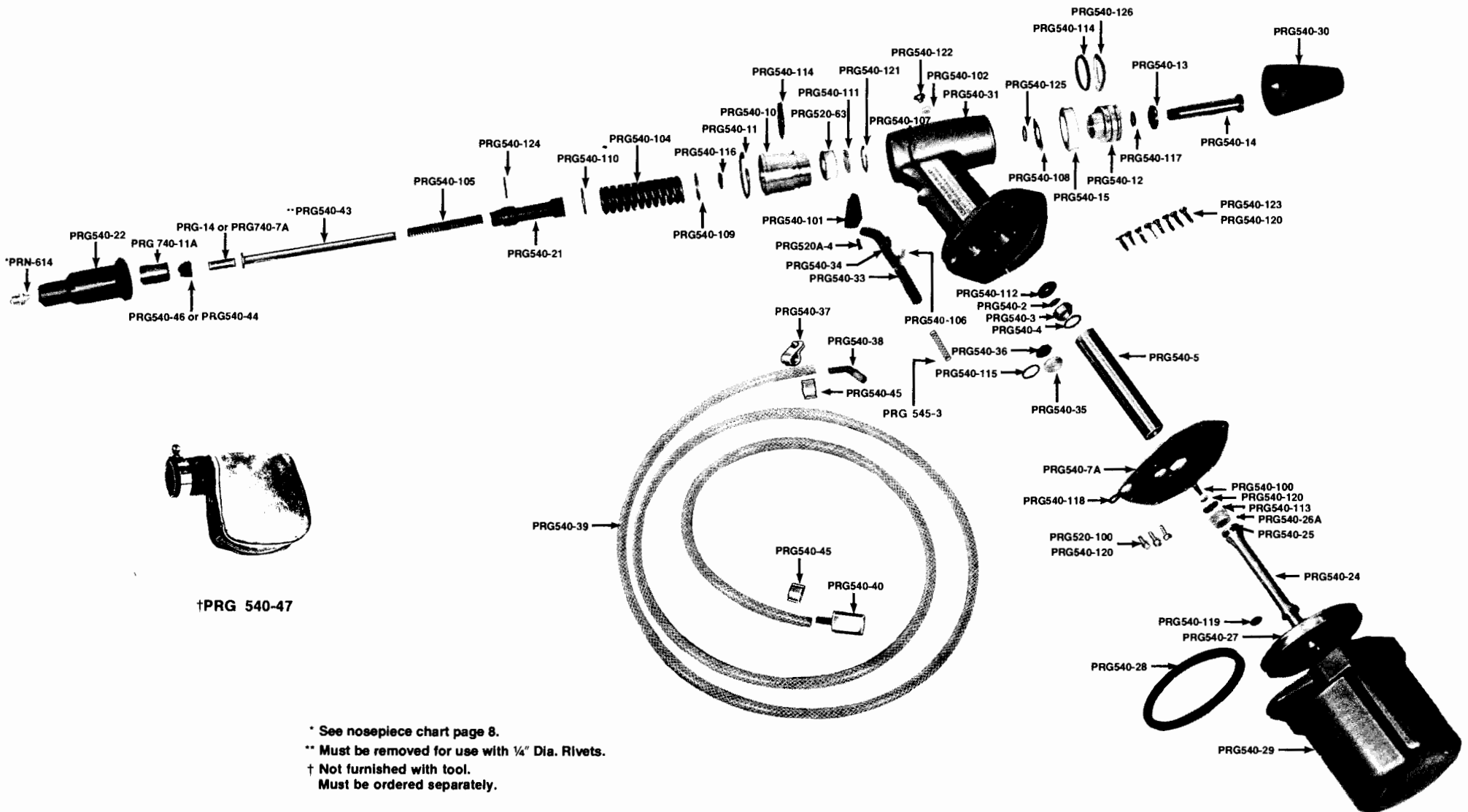

\* See nosepiece chart page 8.  
 \*\* Must be removed for use with 1/4" Dia. Rivets.  
 † Not furnished with tool.  
 Must be ordered separately.

**PRG 540 AIR-HYDRAULIC  
 "POP" RIVET TOOL**



Request Info 1-800-453-1692  
[www.aboveboardelectronics.com](http://www.aboveboardelectronics.com)

# POP<sup>®</sup>

## Blind Rivets

### Emhart Teknologies

#### USA Office

50 Shelton Technology Center  
Shelton, CT 06484  
Tel: 877-EMHART-1  
FAX: 800-225-5614

#### Canada Office

9870 Boulevard du Golf  
Anjou, Quebec Canada  
Tel: 514-351-0330  
FAX: 514-351-0458

#### Mexico Office

Av. Antonio Dovali Jaime No 70  
Torre B Piso 9  
La Fe, Santa Fe  
Mexico, D.F. 01210  
Tel: 52-55-5326-7100  
FAX: 52-55-5236-7141

[www.emhartamericas.com](http://www.emhartamericas.com)

© Emhart Teknologies

P217 (01/12)

**EMHART<sup>®</sup>**  
**TEKNOLOGIES**

*A StanleyBlack&Decker, Inc. Company*



1-800-453-1692

[www.aboveboardelectronics.com](http://www.aboveboardelectronics.com)