

POP[®]

INSTRUCTION MANUAL PRG 510A

Pneumatic Blind Rivet Tool



EMHART[®]
TEKNOLOGIES

SECTION I — GENERAL INFORMATION

The PRG 510 is a Pneumatic Tool suitable for setting all rivets with a break load up to 1,000 pounds. The PRG 510 is equipped to handle various Nosepieces. See Table 1, Page 2, for specific sizes available. The main castings are made of high tensile aluminum, and replacement parts are interchangeable.

PRG 510 WILL SET ONLY THE "POP" RIVETS LISTED IN THIS CHART

RIVET	MANDREL	3/32	7/64	1/8	5/32	3/16
OPEN END RIVETS						
alum.	alum.	●		●	●	●
alum.	steel	●		●	●	●
steel	steel	●		●	●	
monel	steel		●	●		
stainless	stainless			●		
CLOSED END RIVETS						
alum.	alum.			●	●	●
alum.	steel			●		

Table 1 NOSEPIECE NUMBERS			
RIVET DIA.	OPEN END	CLOSED END STEEL MANDREL	CLOSED END ALUM. MANDREL
3/32	PRN-314		
1/8 or 7/64	PRN-414	PRN-424	PRN-434
5/32	PRN-514		PRN-534
3/16	PRN-614		PRN-634

DATA	
Weight of Tool	4 lbs.
Centerline of Nosepiece to Top of Tool	9/16"
Length Including Deflector	9 1/2"
Length With Deflector Collapsed	7"
Length of Stroke	5/8"
Air Pressure	85 P.S.I. (WARNING—Do Not Exceed 85 P.S.I. Air Pressure)
Air Consumption008 CF./Net

Table 2 ACCEPTABLE EQUIVALENTS OF RECOMMENDED LUBRICANT, LUBRIPLATE 130AA	
ESTAN 1 — HUMBLE OIL & REFINING COMPANY	
UNEDO 1 — SHELL OIL COMPANY	
SUN C-891T GREASE — SUN OIL COMPANY	
ALASTAC #10 — TIDEWATER OIL COMPANY	

SECTION II — OPERATION

The following description gives a brief summary of the events that occur when the Trigger is depressed.

1. When Trigger PRG 510-35 is squeezed, Valve Tube PRG 510-37 moves down with Valve Ring Seal PRG 510-107, allowing air to flow to top of Piston PRG 510-43.
2. The air then sets the Piston in motion downward, pulling the Piston Rod PRG 510-41+ with it.
3. This causes the Bell Cranks PRG 510-45 to pivot and the Pulling Head PRG 510-48 to move rearward.

4. As this occurs, Jaws PRG 402-8A grip the mandrel of rivet and pull until rivet is set.

5. When the Trigger is released, the Valve Tube and Valve Ring Seal move up, shutting off the air supply. The air then exhausts out through the Valve Tube.

6. The Piston Rod Return Spring PRG 510-124 returns the Piston and the Jaw Guide PRH 820-11A to their normal positions, allowing the Jaws to open and release the spent mandrel.

SECTION III — CARE AND MAINTENANCE

A. GENERAL

For best results and longer life a regular service procedure should be established and maintained.

The following points should be checked on a regular maintenance basis.

1. Under normal working conditions, foreign matter will accumulate in the Jaw Pulling mechanism and hinder its normal operation. To prevent this build-up and to lubricate the pulling mechanism, the following procedure is recommended. NO disassembly of the tool is required.
 - a. Clear tool of spent mandrels.
 - b. Dip Nose Housing 1 1/2" into Jaw Lube PRG 510-130.
 - c. While immersed, cycle tool several times, pausing between cycles.
 - d. Remove tool, wipe outer surface clean.
 - e. For alternate method, see Section III A2. Use ONLY recommended lubricants or equivalent.

2. Eventually, dirt build-up may require front end disassembly and cleaning. In this event, the following procedure should be followed.

- a. Disassemble as described in Section IV E1.
 - b. Clean all parts thoroughly including the Nose Housing PRG 510-52A Cavity. Clean serrations in Jaw Teeth with a wire brush if necessary.
 - c. Inspect Jaws and replace if teeth are worn.
 - d. Measure Jaw Pusher Spring PRG 510-123 and replace if length is less than 2 inches.
 - e. Lubricate and reassemble as described in Section IV E2, making certain that the Jaw Guide, Nose Housing, and Nosepiece are tightened.
3. About every 100,000 cycles, the three bearings in the Bell Crank and the associated Pins should be liberally relubricated with Lubriplate 130AA or equivalent.
- a. Remove Housing Cap PRG 511-076.
 - b. With small brush, force new grease between Bell Cranks PRG 510-45 and Piston Rod PRG 510-41+ so that it will work onto Piston Rod Fulcrum PRG 510-113.
 - c. With air pressure on tool, use tape or rubber band to hold Trigger PRG 510-35 in pulling position. Remove Retaining Ring PRG 510-122, Bell Crank Fulcrum PRG 510-126 and the two Outer Bell Crank Bushings PRG 510-46. Use brush to force new grease through holes in Housing to work around Bell Cranks and Center Bell

- Crank Bushing PRG 510-47. Wipe some grease onto Outer Bushings and Fulcrum Pin, and reassemble.
- d. With small brush, force new grease between Bell Cranks and Pulling Head Fulcrum PRG 510-49.
- e. Release Trigger and reassemble Housing Cap.

B. AIR HOSE REPLACEMENT

In the event the Air Line PRG 540-39 is crushed or damaged in some manner, it may be repaired or replaced, depending on the amount of damage, by using the following procedure:

1. Remove Air Line Clamp PRG 540-45 by cutting or deforming the ears which project on either side. In doing this, the Clamp will be permanently damaged, and for this purpose two extra Clamps are included on the Air Line.
2. Remove faulty Air Line from Hose Adapter PRG 510-58 and insert new or repaired Air Line.
3. Tighten new Clamp by squeezing with pliers both ears on either side of Clamp.

NOTE

Insertion of new Air Line may be facilitated by dipping end of Air Line into hot water to make it more flexible.

SECTION IV — DISASSEMBLY AND ASSEMBLY

A. GENERAL

In assembling or disassembling this tool, care should be taken that foreign matter does not get into the tool.

When ordering replacement parts, order by part number shown on Page No. 7.

CAUTION

Shut off air supply to the tool before proceeding with any assembly or disassembly procedures.

B. AIR PISTON AND AIR PISTON SEAL

1. Disassembly

- a. Unscrew nine Base Screws PRG 510-116, and remove Washers PRP-101.
- b. Remove Base PRG 510-33, being careful not to lose Base Air Seal "O" Ring PRG 510-107.
- c. Remove Piston Bumper PRG 510-54.
- d. Unscrew Piston Rod Screw PRG 510-102. Tip to one side to facilitate removal of Piston PRG 510-43, Washer PRG 510-103 and Washer PRG 510-110.

- e. Remove Piston Seal PRG 510-44.
- f. Clean air cylinder in Handle PRG 510-31 and lubricate cylinder walls with recommended lubricant.

2. Assembly

- a. Attach Piston Seal PRG 510-44 to Piston PRG 510-43.
- b. Apply recommended lubricant to Seal and insert assembly into bottom of Housing. Be sure flat side of Piston is facing the bottom of the tool.
- c. Secure Piston with Screw PRG 510-102 and Washers PRG 510-103 and PRG 510-110.
- d. Insert Piston Bumper PRG 510-54 into Housing.
- e. Apply a light coating of lubricant to Base Air Seal PRG 510-107 so as to retain it in the Base PRG 510-33.
- f. Attach Base PRG 510-33 to Housing with nine Screws PRG 510-116 and Washers PRP-101.

C. TRIGGER ASSEMBLY

1. Disassembly

- a. Remove Trigger Fulcrum Pin PRG 510-120.
- b. Remove Trigger and Trigger Lever from Housing.
- c. Remove Trigger Pin PRG 510-118 from Trigger PRG 510-35 and Trigger Lever PRG 510-36A.

2. Assembly

- a. Attach Trigger PRG 510-35 and Trigger Lever PRG 510-36A with Trigger Pin PRG 510-118.
- b. Insert Trigger assembly into Housing and locate hole in Trigger Lever relative to fulcrum hole in Housing by holding up to light and orienting with a rod, such as mandrel of $\frac{3}{16}$ " "POP" Rivet.
- c. Drive Trigger Fulcrum Pin PRG 510-120 into Housing and carefully through holes in Trigger Lever, using above rod to maintain alignment.

D. VALVE ASSEMBLY

1. Disassembly

- a. Remove Base and Piston per Section IV, Paragraph B1.
- b. Remove Valve Plate PRG 510-39+ by removing two Valve Plate Screws PRG 510-115 and two Lock Washers PRG 510-111.
- c. Withdraw Valve Assembly from Housing.
- d. Using Truarc Pliers, remove Retainer Rings PRG 510-122 from each end of Valve Tube PRG 510-37.
- e. Remove Valve Tube Cap PRG 510-112, Valve Tube Seal PRG 520-60, Valve Seat Seal PRG 510-106, Valve Ring Seal Washer PRG 510-109, Valve Ring Seal PRG 510-107, Valve Seat PRG 510-38, and remaining Retainer Ring PRG 510-122 from Valve Tube.

2. Assembly

- a. Attach Retainer Ring PRG 510-122 to upper end of Valve Tube PRG 510-37.
- b. Position Valve Tube Cap PRG 510-112, Valve Tube Seal PRG 520-60, middle Retainer Ring PRG 510-122, Valve Seat Seal PRG 510-106, and Valve Seat PRG 510-38 on Valve Tube PRG 510-37.
- c. Position Valve Ring Seal PRG 510-107 and Valve Ring Seal Washer PRG 510-109 on Valve Tube PRG 510-37 and retain in place with third Retainer Ring PRG 510-122.
- d. Lubricate Valve Seals lightly with recommended Lubricant and insert assembly into Housing.
- e. Retain in place with Valve Plate PRG 510-39+ and two Screws PRG 510-115 and two Lock Washers PRG 510-111.
- f. Assemble Piston as per Section IV, Paragraph B2.

E. JAWS, JAW PUSHER, JAW GUIDE, JAW PUSHER SPRING TUBE, AND JAW PUSHER SPRING

1. Disassembly

- a. Remove Nose Housing PRG 510-52A and Nosepiece.
- b. Remove Jaw Guide PRH 820-11A.
- c. Remove Jaws PRG 402-8A, Jaw Pusher PRG 520-33, and Jaw Pusher Spring PRG 510-123.

2. Assembly

- a. Lightly lubricate outside of Jaw Pusher Spring PRG 510-123 and insert into Pulling Head PRG 510-48.

- b. Lightly lubricate conical surface of Jaws PRG 402-8A and drop Jaws in place in Jaw Guide PRH 820-11A.
- c. Lightly lubricate outside of Jaw Pusher PRG 520-33 and drop in place in Jaw Guide and attach to Pulling Head PRG 510-48.
- d. Attach Nose Housing PRG 510-52A and Nosepiece to Tool Housing PRG 510-31.
- e. See Section III A1 for alternate lubrication method.

F. PULLING HEAD, PISTON HEAD AND RETURN SPRING

1. Disassembly

- a. Remove Housing Cap PRG 511-076 by removing two Housing Cap Screws PRG 510-117.
- b. Remove Nosepiece and screw in a $\frac{3}{8}$ -24 screw (approx. 1" long) in place of Nosepiece until Pulling Head mechanism is moved rearward approximately $\frac{5}{8}$ " (16MM) exposing wrench flats on Mandrel Guide.
- c. Loosen, but do not remove Mandrel Guide PRG 511-051 as Mandrel Tube PRG 510-50 will fly out under spring pressure. Remove $\frac{3}{8}$ -24 Screw.
- d. Remove Jaw Assembly as per Section IV, Paragraph E1.
- e. Remove Air Piston as per Section IV, Paragraph B1.
- f. Remove Mandrel Guide PRG 511-051.
- g. Remove Fulcrum Retaining Ring PRG 510-122. Place screwdriver blade under lip of PRG 510-31 Housing and press down on top of Piston Rod PRG 510-41 + and remove Bell Crank Fulcrum PRG 510-126. If tension has not been released sufficiently to remove Bell Crank Fulcrum, rotate screwdriver blade 90° and follow same procedure.
- h. Relieve pressure and remove Piston Rod Fulcrum PRG 510-113.
- i. Remove Outer Bell Crank Bushings PRG 510-46.
- j. Rotate Piston Rod PRG 510-41 + so that Roll Pin is centered between Bell Cranks PRG 510-45 and remove.
- k. Remove Spring Cap PRG 510-42 and remove Piston Rod Return Spring PRG 510-124.
- l. Lift rear ends of Bell Cranks PRG 510-45 and draw them and Pulling Head Assembly up and to the back to remove from Housing.
- m. Remove the Spring Washer PRG 510-105 and Center Bell Crank Bushing PRG 510-47 from the Housing.
- n. Remove two Bell Cranks PRG 510-45 from Pulling Head Fulcrum PRG 510-49.
- o. Remove Mandrel Tube PRG 511-050 and Pulling Head Fulcrum PRG 510-49 from Pulling Head PRG-510-48.
- p. Remove Valve Plate as per section IV, Paragraph D 1b.
- q. Remove Piston Rod Seal PRG 510-114 and Piston Rod Seal Washer PRG 510-104.

2. Assembly

NOTE

All bearing and pivot points should be lightly lubricated with recommended lubricant or equivalent.

- a. Insert Pulling Head Fulcrum PRG 510-49 into Pulling Head PRG 510-48.
- b. Insert Mandrel Tube PRG 510-50 into bore of Pulling Head and through Pulling Head Fulcrum.
- c. Attach the Bell Cranks PRG 510-45 to the Pulling Head Fulcrum.
- d. Place the Spring Washer PRG 510-105 at the bottom of the bore in the Housing.
- e. Position Center Bell Crank Bushing PRG 510-47 into Housing.
- f. Insert Pulling Head Assembly into Housing.
- g. Insert Piston Rod Return Spring PRG 510-124 into the Housing on top of the Spring Washer PRG 510-105.
- h. Insert the Spring Cap PRG 510-42 into the Piston Rod Return Spring PRG 510-124.
- i. Insert the Piston Rod PRG 510-41+ through the Spring Cap PRG 510-42 and Piston Rod Return Spring PRG 510-124.
- j. Align the fulcrum holes in the Piston Rod and the Bell Cranks and insert the Piston Rod Fulcrum PRG 510-113.
- k. With screwdriver blade push down on Piston Rod PRG 510-41 + as far as it will go, place one outer Bell Crank Bushing PRG 510-46 over Bell Crank Fulcrum PRG 510-126 and insert through the Housing and lower holes of the Bell Cranks.
- l. Insert the second outer Bell Crank Bushing PRG 510-46 into the other side of the Housing and retain with the Fulcrum Retaining Ring PRG 510-122.
- m. Hand tighten Mandrel Guide PRG 511-051 into rear of Pulling Head.
- n. Insert Piston Rod Seal Washer PRG 510-104 and Piston Rod Seal PRG 510-114 over end of Piston Rod PRG 510-41 +.
- o. Reassemble Valve Plate as per Section IV, Paragraph D 2e.
- p. Reassemble Air Piston as per Section IV, Paragraph B2.
- q. Reassemble Jaw Assembly as per Section IV, Paragraph E2.
- r. Attach tool to Air Line and cycle. Hold Trigger and tighten Mandrel Guide PRG 511-051.
- s. Place Housing Cap 511-076 on Housing and secure with two Housing Cap Screws PRG 510-117.

SECTION V — TROUBLE SHOOTING

TROUBLE	PROBABLE CAUSE	REMEDY
Jaws Slipping on Mandrels	Dirt in Jaw Teeth	Clean Jaws See Section III A1, 2
	Worn Jaw Teeth	Replace Jaws See Section III A2
	Fatigued Jaw Pusher Spring	Replace See Section III A2
Jaws Fail to Open	Nosepiece or Nose Housing Loose	Tighten
	Jaws Sticking	Clean Jaws & Lubricate See Section III A
	Fatigued Return Spring	Replace See Section IVF
Slow Pulling Action	Dirt packed toward front of Nose Housing	Clean See Section III A 2
	Air Line or Air Passage Plugged	Repair See Section III B
	Insufficient Air Pressure	Check Air Supply
	Worn Piston Seal	Replace See Section IV B
	Damaged Air Valve	Replace See Section IV D
	Dirt in restrictor hole of Piston Bumper	Clean See Section IV B
	Foreign material inside Housing	Clean See Section IV F

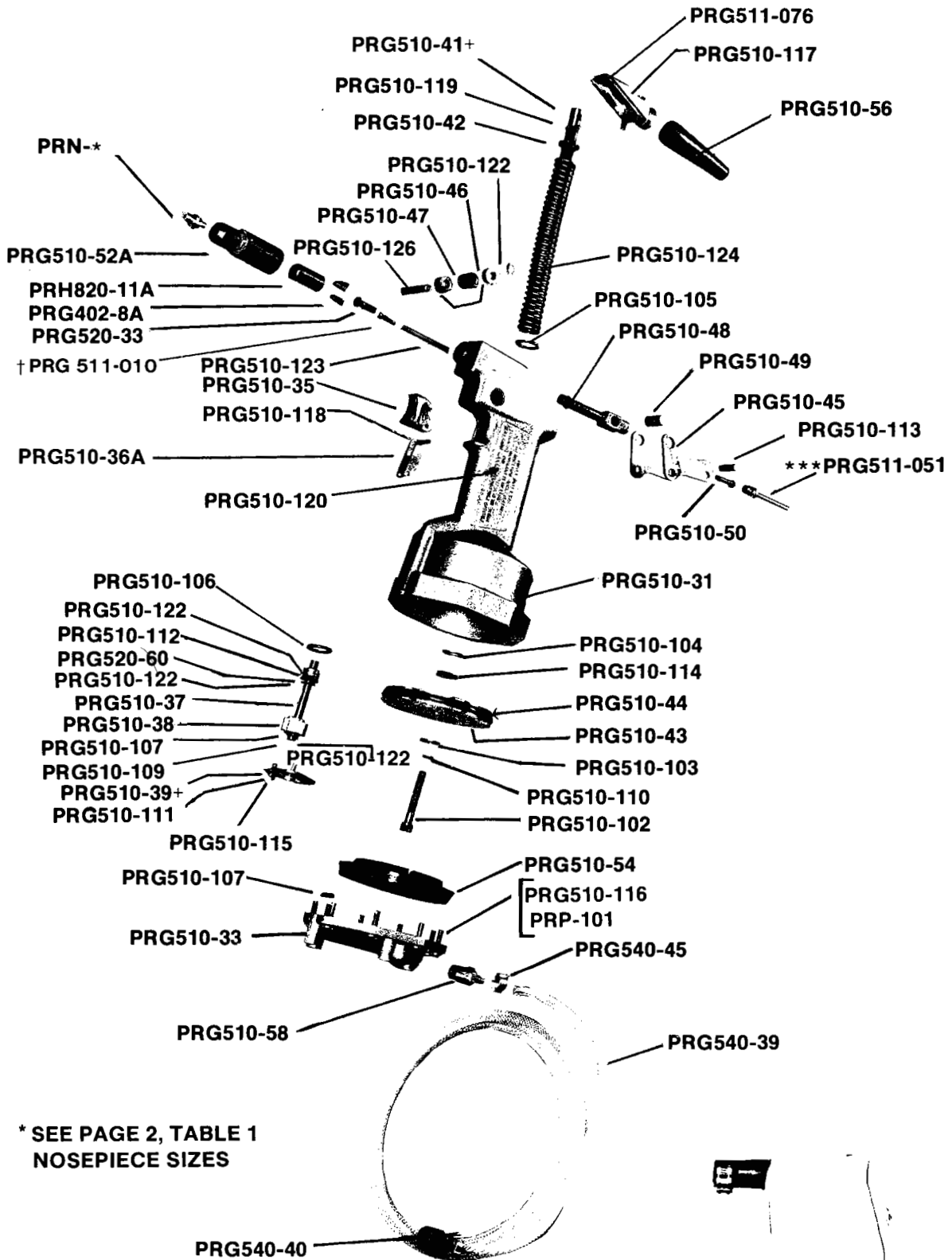

* SEE PAGE 2, TABLE 1
NOSEPIECE SIZES

†PRG510-69
MANDREL CATCHER

† Not furnished with tool.
Must be ordered separately.

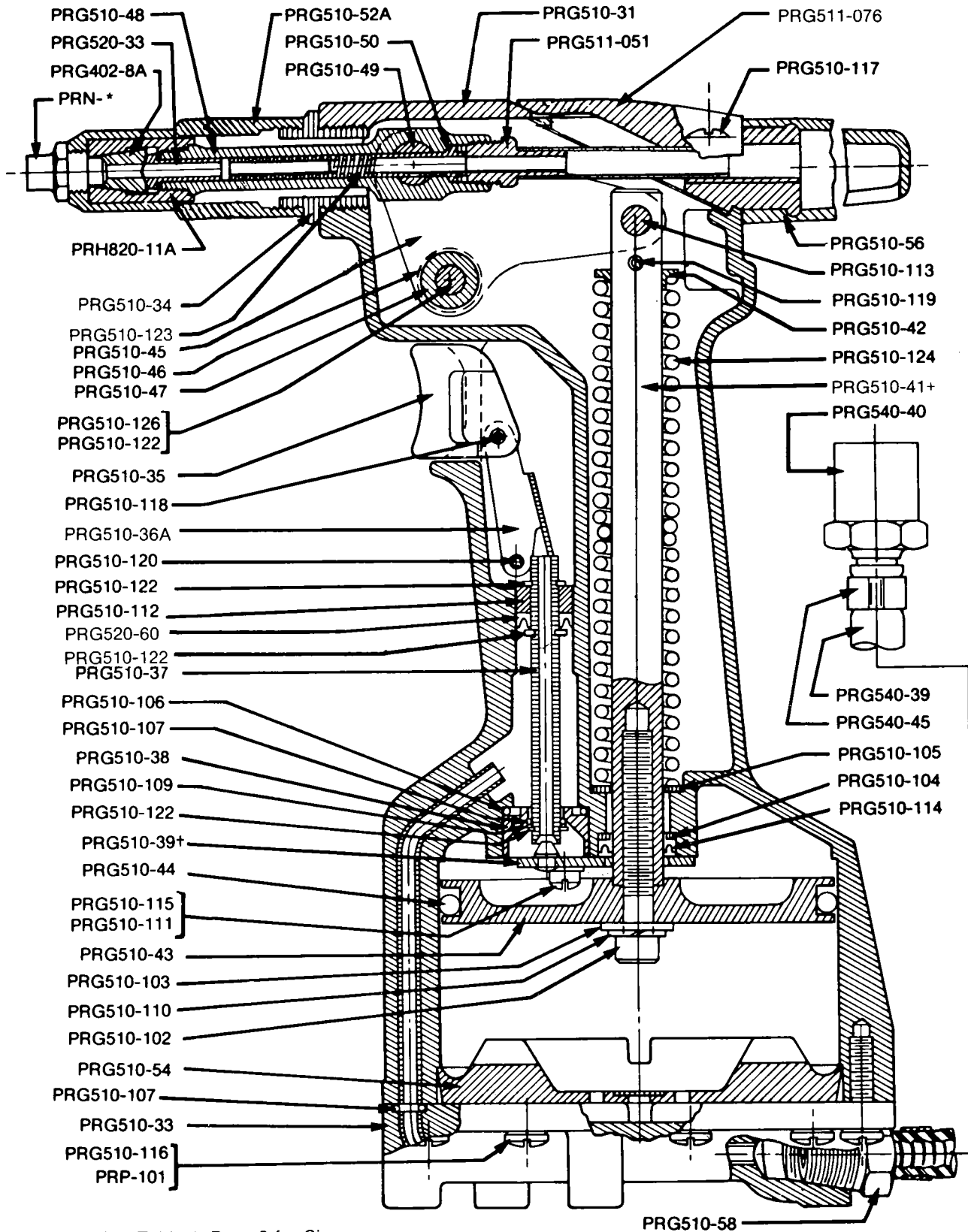

* See Table 1, Page 2 for Sizes.

**Emhart Fastening Technologies
Industrial Division**

Headquarters:
510 River Road, P.O. Box 859
Shelton, CT 06484
Tel. (203) 924-9341
Fax (203) 925-3109

California Office & Warehouse
1402 McGaw
Irvine, CA 92614
Tel. (949) 851-2298
Fax (949) 851-2099

Canadian Office & Warehouse
3545 Thimens Boulevard
St. Laurent, Quebec, H4R 1V5
Tel. (514) 333-8080
Fax (514) 338-3829

Mexico
Bosque de Radiatas No.42
Col. Bosques de las Lomas
05120 México, D.F.
Tel. (52-5) 326-71-00
Fax (52-5) 326-71-41

Brasil
REFAL
Rua Ricardo Cavatton, 226
CEP 05038-110 São Paulo SP
Tel. (011) 861-3586
Fax (011) 861-3505



Request Info
* * *

1-800-453-1692

www.aboveboardelectronics.com



PRG 510A

Addendum to the PRG510 manual No P-218

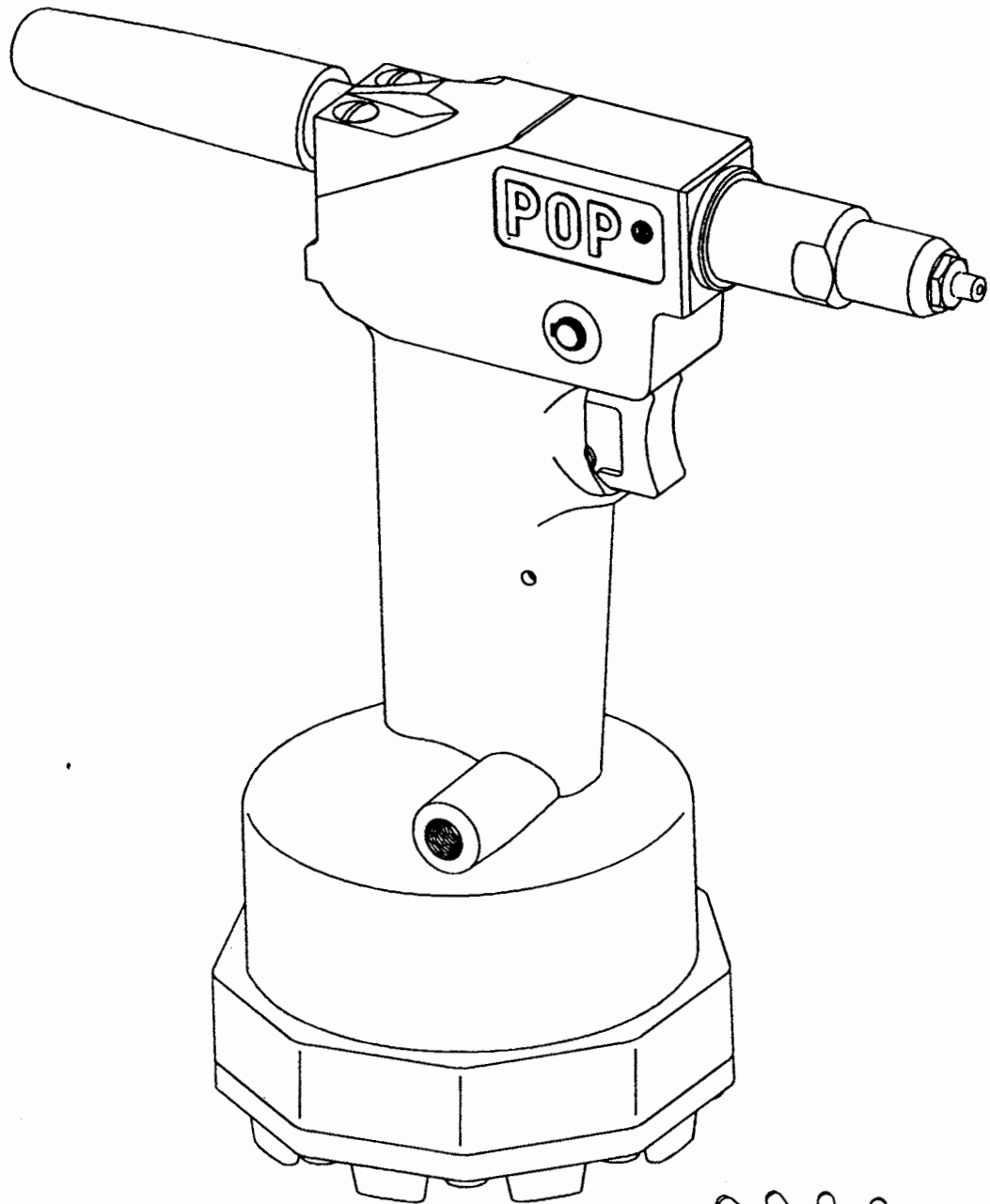

Emhart
POP

A BLACK&DECKER COMPANY

Series 510A

Addendum to the PRG510 manual No P-218

The PRG 510A tool is an enhanced version of our PRG510 pneumatic POP® rivet tool, therefore, most of the components are interchangeable. Table A1 provides information that identifies components that are unique to the 510A series tools. It also lists 510 components not used in the 510A.

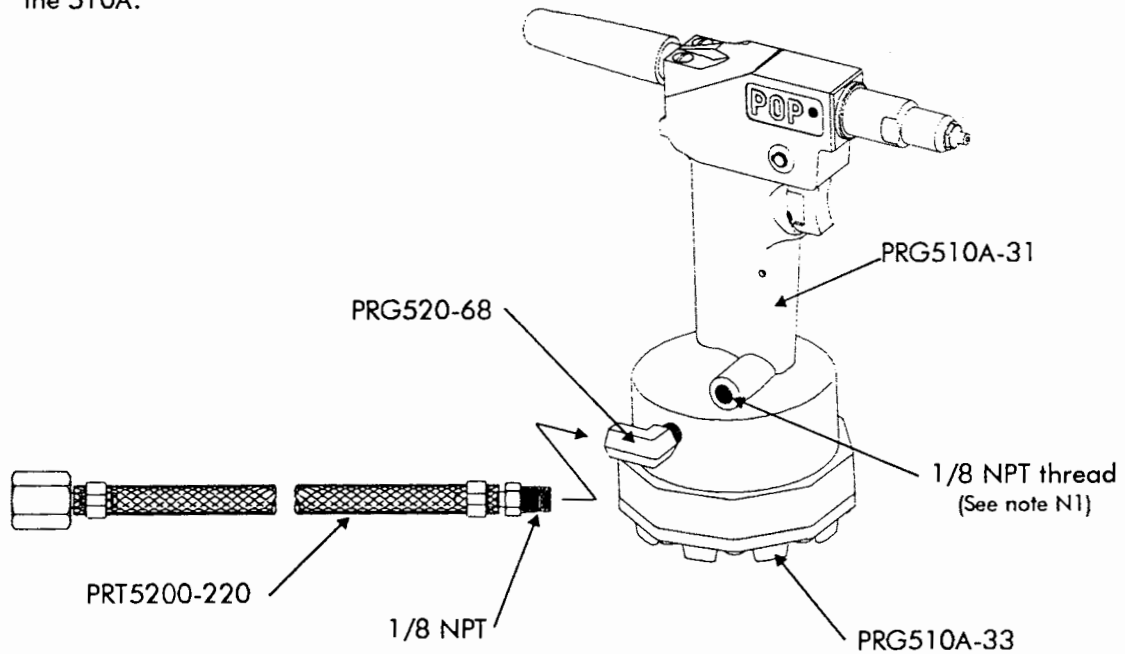

Table A1

Description	PRG510A-PLUS Part number	PRG510A Part number	Replaces 510 tool Part number in manual
Elbow Fitting	PRG520-68	PRG520-68	None Provided
Housing	PRG510A-31	PRG510A-31	PRG510-31
Base	PRG510A-33	PRG510A-33	PRG510-33
O'ring (Qty. 1)	PRG510-107	PRG510-107	Qty. Change only
Air Line Assembly	PRT5200-220		See note (N2)
Jaw Service Kit (N3)	PRG510A230		



Request Info

1-800-453-1692



www.aboveboardelectronics.com

NOTES :

- N1** The 510A air supply inlet is located just below the housing grip and is a 1/8 N.P.T. thread. The 510 air hose assembly uses a 1/4 N.P.T. and will not fit. Use part number PRT5200-220 air hose assembly.
- N2** The air supply hose provided with the PRG510 tools are made up of PRG540-39 Air Line (Qty 1), PRG540-40 Hose Female Fitting (Qty 1), PRG540-45 air line "O" Clamp (Qty 2), PRG510-58 Hose Adapter-1/4 NPT.
- N3** The Jaw Service Kit consists of PRG402-8A Jaw (Qty 2), PRG520-33 Jaw Pusher (Qty 1), PRG510-123 Jaw Pusher Spring (Qty 1).

INSTRUCTION MANUAL

**Series 510A Pneumatic
POP® Rivetools,
MCS 510A, PRG 510A,
MCS 511A, PRG 511A
and PRG 510A Plus.**

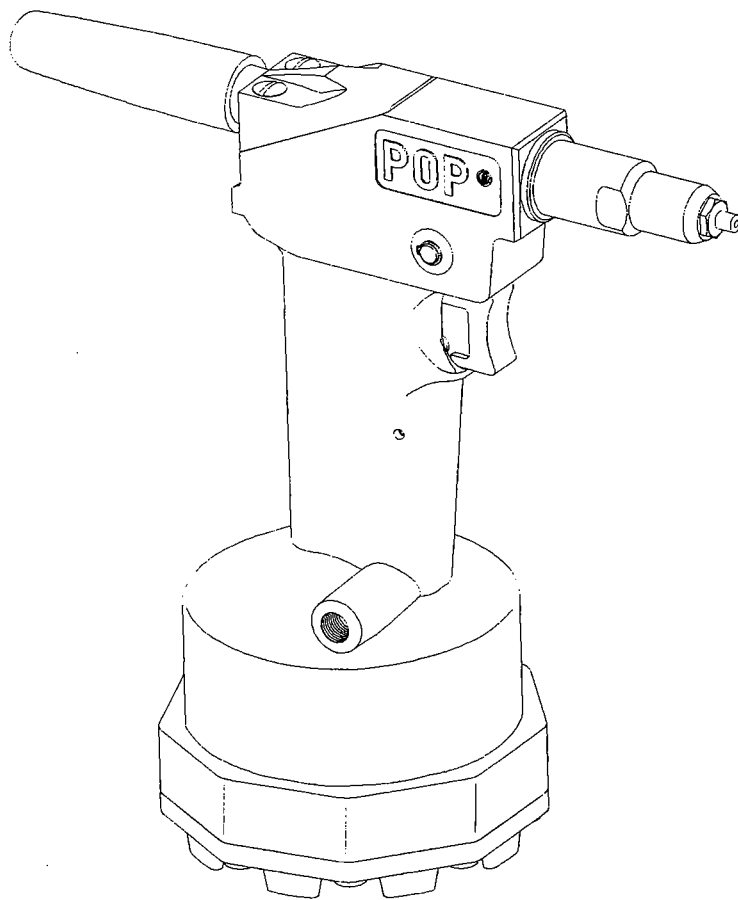

Emhart
POP

A BLACK & DECKER COMPANY

**PRG 510A-PLUS
PRG 510A**

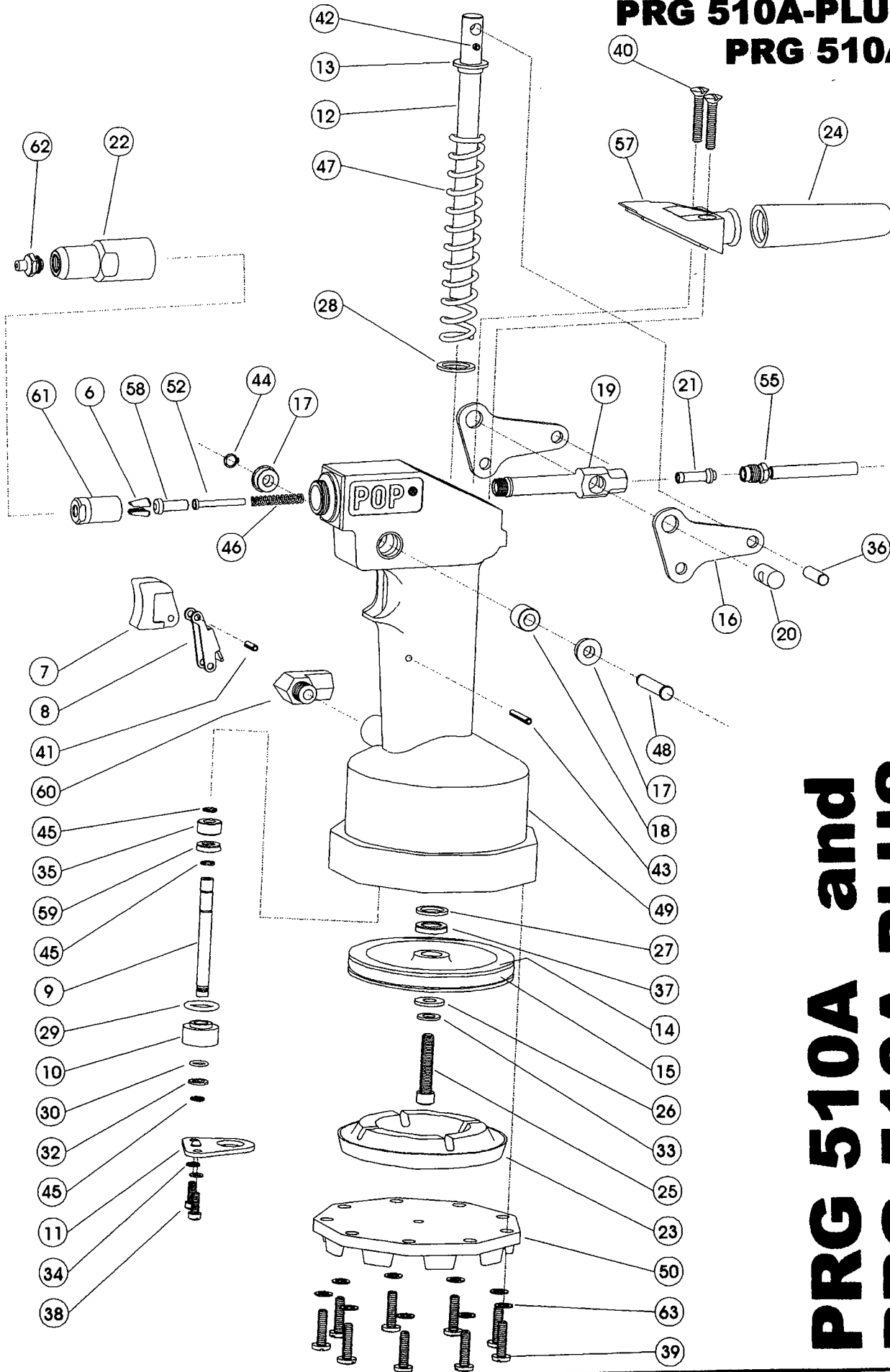

**PRG 510A and
PRG 510A-PLUS**

MCS 510A

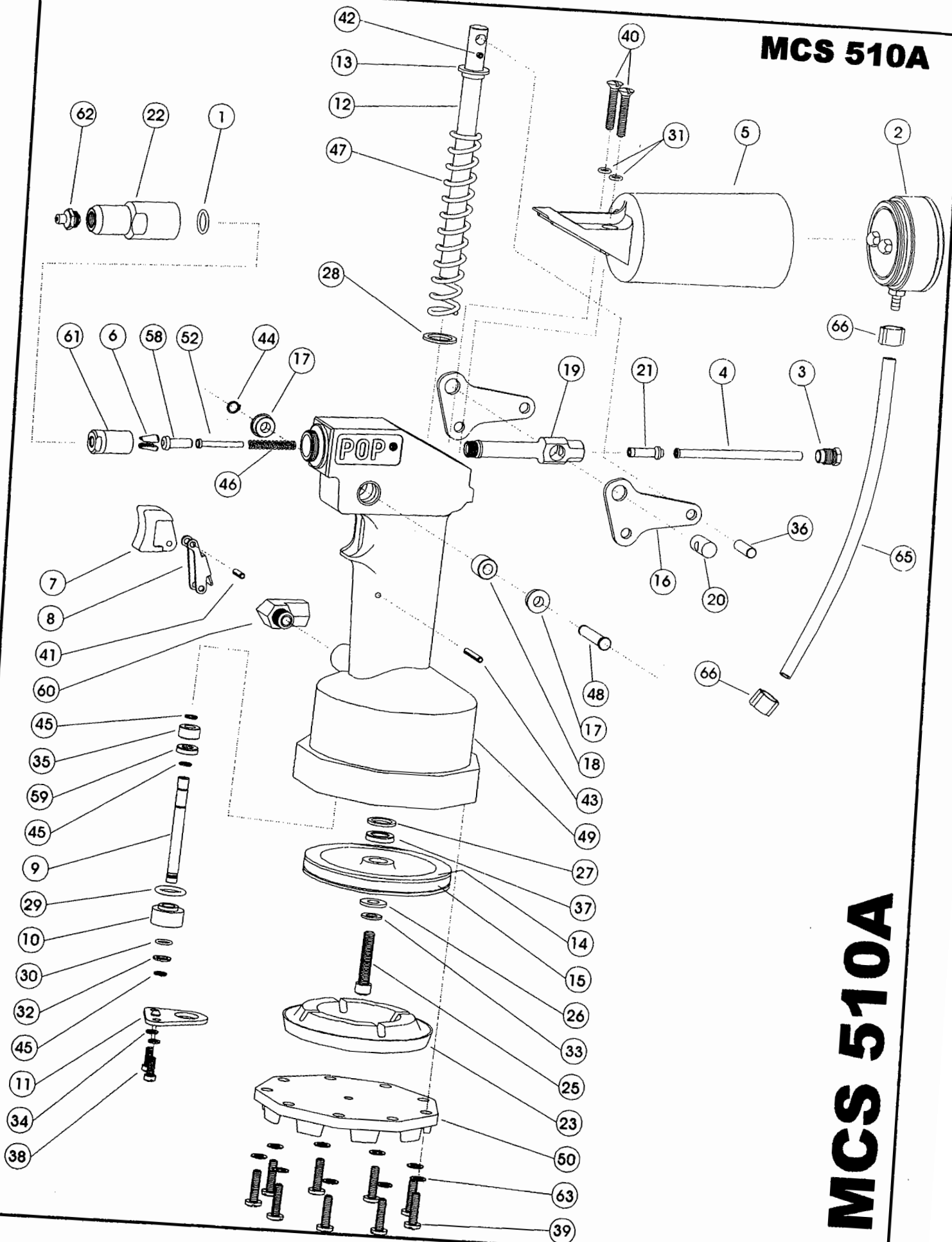

MCS 510A

ITEM	PART NUMBER	DESCRIPTION	MCS510A	MCS511A	PRG510A	PRG510A PLUS	PRG511A
	1	MCS500-34	NOSE HOUSING O-RING	1	1		
	2	MCS500-101	VACUUM CAP	1	1		
	3	MCS510-11	MANDREL GUIDE NUT	1	1		
	4	MCS510-12	MANDREL GUIDE	1	1		
	5	MCS510-101	COLLECTOR BOTTLE ASSEMBLY	1	1		
	6	PRG402-8A	JAW	2	2	2	2
N1	7	PRG510-35	TRIGGER	1	1	1	1
N1	8	PRG510-36A	TRIGGER LEVER	1	1	1	1
N2	9	PRG510-37	VALVE TUBE	1	1	1	1
N2	10	PRG510-38	VALVE SEAT	1	1	1	1
	11	PRG510-39+	VALVE PLATE	1	1	1	1
	12	PRG510-41+	PISTON ROD ASSEMBLY	1	1	1	1
	13	PRG510-42	SPRING CAP	1	1	1	1
	14	PRG510-43	PISTON	1	1	1	1
	15	PRG510-44	PISTON SEAL	1	1	1	1
	16	PRG510-45	BELL CRANK	2	2	2	2
	17	PRG510-46	BELL CRANK BUSHING	2	2	2	2
	18	PRG510-47	BELL CRANK BUSHING CENTER	1	1	1	1
	19	PRG510-48	PULLING HEAD	1	1	1	1
	20	PRG510-49	PULLING HEAD FULCRUM	1	1	1	1
	21	PRG510-50	MANDREL TUBE	1		1	
	22	PRG510-52A	NOSE HOUSING	1		1	
	23	PRG510-54	PISTON BUMPER	1	1	1	1
	24	PRG510-56	DEFLECTOR			1	1
	25	PRG510-102	PISTON ROD SCREW	1	1	1	1
	26	PRG510-103	PISTON ROD WASHER	1	1	1	1
	27	PRG510-104	PISTON ROD SEAL WASHER	1	1	1	1
	28	PRG510-105	SPRING WASHER	1	1	1	1
N2	29	PRG510-106	VALVE SEAT SEAL	1	1	1	1
	30	PRG510-107	BASE AIR SEAL	1	1	1	1
N2	31	PRG510-107	BASE AIR SEAL	2	2		
N2	32	PRG510-109	VALVE RING SEAL WASHER	1	1	1	1
	33	PRG510-110	PISTON ROD LOCKWASHER	1	1	1	1
	34	PRG510-111	VALVE PLATE SCREW LOCKWASHER	2	2	2	2
	35	PRG510-112	VALVE TUBE CAP	1	1	1	1
	36	PRG510-113	PISTON ROD FULCRUM	1	1	1	1
	37	PRG510-114	PISTON ROD SEAL	1	1	1	1
	38	PRG510-115	VALVE PLATE SCREW	2	2	2	2
	39	PRG510-116	BASE SCREW	9	9	9	9
	40	PRG510-117	HOUSING CAP SCREW	2	2	2	2
N1	41	PRG510-118	TRIGGER PIN	1	1	1	1
	42	PRG510-119	PISTON ROD PIN				
	43	PRG510-120	TRIGGER FULCRUM PIN	1	1	1	1

ITEM	PART NUMBER	DESCRIPTION	MCS510A	MCS511A	PRG510A	PRG510A PLUS	PRG511A
N2	44	PRG510-122	VALVE RING SEAL RETAINER	1	1	1	1
	45	PRG510-122	VALVE RING SEAL RETAINER	3	3	3	3
	46	PRG510-123	JAW PUSHER SPRING	1	1	1	1
	47	PRG510-124	PISTON ROD RETURN SPRING	1	1	1	1
	48	PRG510-126	BELL CRANK FULCRUM	1	1	1	1
	49	PRG510A-31	HOUSING	1	1	1	1
	50	PRG510A-33	BASE	1	1	1	1
N3	51	PRG510A-59	ADAPTOR FITTING			1	
N3	52	PRG511-010	JAW PUSHER SPRING TUBE		1		1
	53	PRG511-022	PULLING HEAD ADAPTOR (EXT.)		1		1
	54	PRG511-050	MANDREL TUBE		1		1
	55	PRG511-051	MANDREL GUIDE	1	1	1	1
	56	PRG511-052	NOSE HOUSING		1		1
	57	PRG511-076	HOUSING CAP			1	1
	58	PRG520-33	JAW PUSHER	1	1	1	1
N2	59	PRG520-60	VALVE TUBE SEAL	1	1	1	1
	60	PRG520-68	ELBOW FITTING	1	1	1	1
	61	PRH820-11A	JAW GUIDE	1	1	1	1
	62	PRN414	NOSEPIECE	1	1	1	1
	63	PRP-101	JAW PUSHER WASHER	9	9	9	9
	64	PRG510-230	JAW SERVICE KIT				1
	65	MCS100-35	TRANSDUCER TUBE	1	1		
	66	PRG520A-8	AIR LINE O-CLAMP	2	2		
N4	70	PRT5200-90	AIR LINE FITTING				1
N4	71	PRG540-40	HOSE FEMALE FITTING				1
N4	72	PRG540-45	AIR LINE O-CLAMP				2
N4	73	PRG540-39	AIR LINE (HOSE)				1
N5	74	MCS500-31	HOSE CONNECTION ASSEMBLY	1	1		
N5	75	PRT5200-90	AIR LINE FITTING	1	1		
N5	76	PRG540-39	AIR LINE (HOSE)	2	2		
N5	77	PRG540-40	HOSE FEMALE FITTING	1	1		
N5	78	PRG540-45	AIR LINE O-CLAMP	4	4		

N1 = These parts must be ordered as an assembly. Order part number PRG510-170.

N2 = These parts must be ordered as an assembly. Order part number PRG510-180.

N3 = These parts are optional on some tools and are shown for identification only.

N4 = These parts must be ordered as an assembly. Order part number PRT5200-220.

N5 = These parts must be ordered as an assembly. Order part number MCS510A-220.

PRG 511A

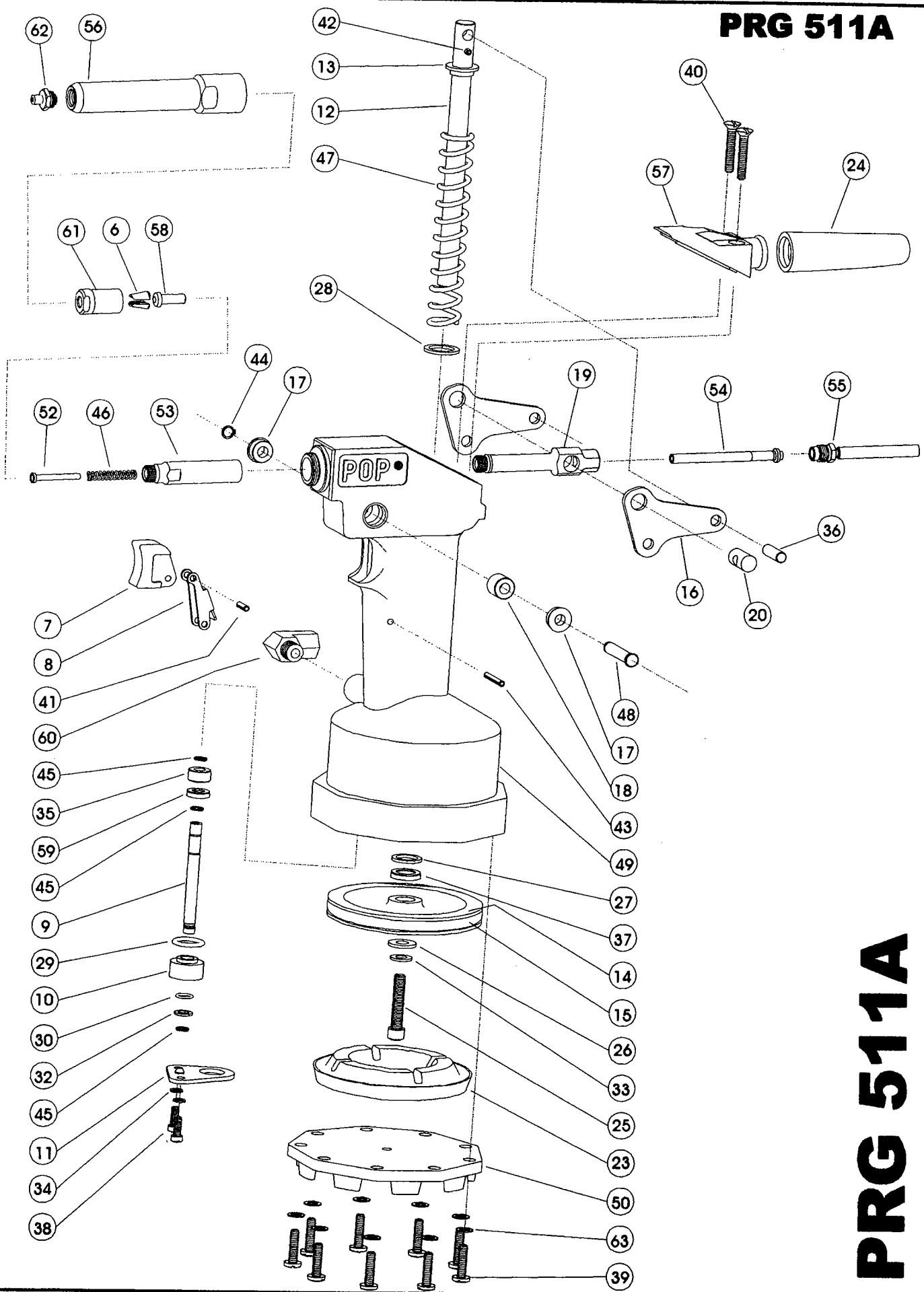

PRG 511A

MCS 511A

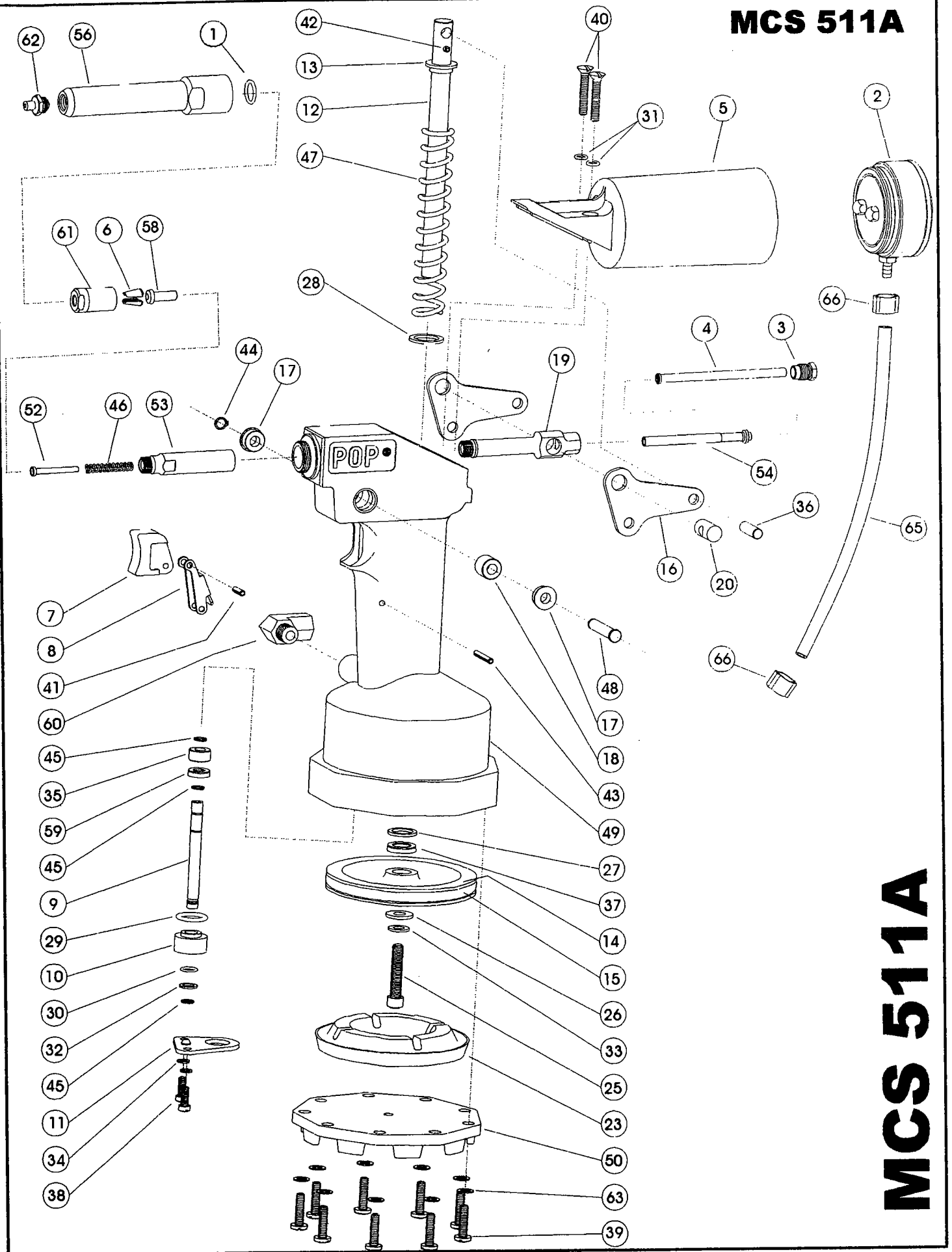

MCS 511A

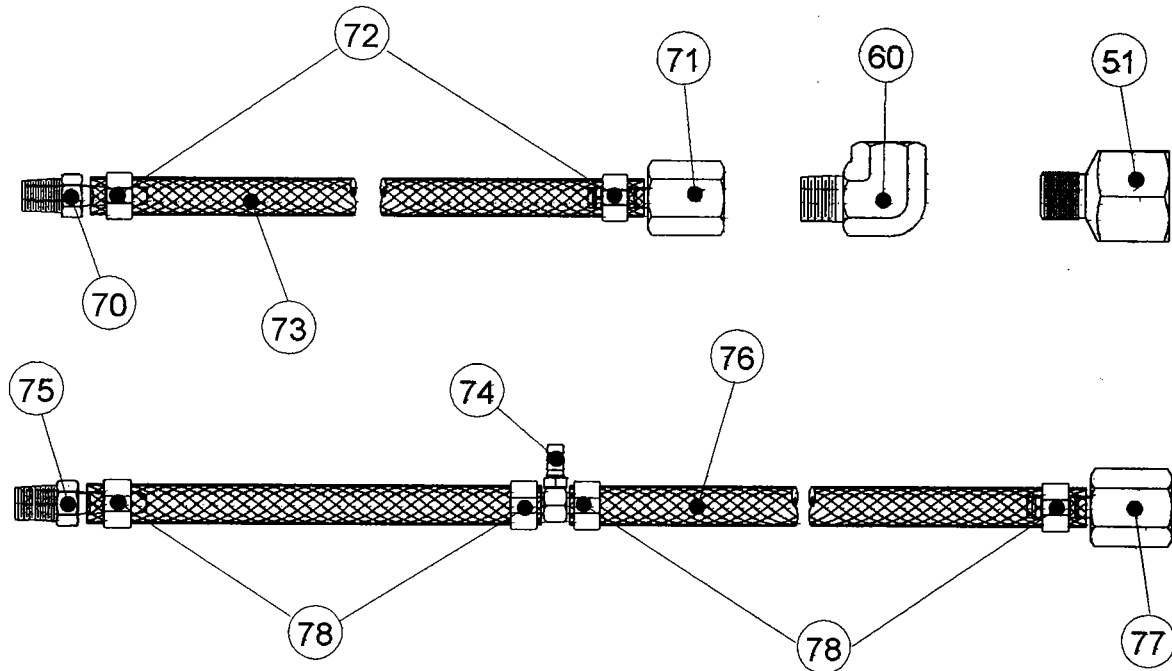

The PRG510A tool is an enhanced version of our PRG510 pneumatic POP® rivet tool, therefore most of the components are interchangeable. The following table summarizes the differences between the tools.

DESCRIPTION	PRG510A-PLUS	PRG510A	PRG510
ELBOW FITTING	PRG520-68	PRG520-68	NONE PROVIDED
HOUSING	PRG510A-31	PRG510A-31	PRG510-31
BASE	PRG510A-33	PRG510A-33	PRG510-33
O-RING	PRG510-107	PRG510-107	QTY. CHANGE ONLY
AIR LINE ASSEMBLY	PRT5200-220		
* JAW SERVICE KIT	PRG510A-230		

* The PRT510A-230 Jaw Service Kit consists of PRG402-8A Jaw (2), PRG520-33 Jaw Pusher (1), and PRG510-123 Jaw Pusher Spring (1).



Request Info
1-800-453-1692
www.aboveboardelectronics.com

**Emhart Fastening Technologies
Industrial Division**

Headquarters:
510 River Road, P.O. Box 859
Shelton, CT 06484
Tel. (203) 924-9341
Fax (203) 925-3109

California Office & Warehouse
1402 McGaw
Irvine, CA 92614
Tel. (949) 851-2298
Fax (949) 851-2099

Canadian Office & Warehouse
3545 Thimens Boulevard
St. Laurent, Quebec, H4R 1V5
Tel. (514) 333-8080
Fax (514) 338-3829

Mexico
Bosque de Radiatas No.42
Col. Bosques de las Lomas
05120 México, D.F.
Tel. (52-5) 326-71-00
Fax (52-5) 326-71-41

Brasil
REFAL
Rua Ricardo Cavatton, 226
CEP 05038-110 São Paulo SP
Tel. (011) 861-3586
Fax (011) 861-3505



PRINTED IN U.S.A.
Visit our Website @ www.emhart.com

© Reg. U.S. Pat. Off.

P218A (Addendum to P218) 02/99 (2M)

A BLACK & DECKER COMPANY

POP[®]

Blind Rivets

Emhart Teknologies

USA Office

50 Shelton Technology Center
Shelton, CT 06484
Tel: 877-EMHART-1
FAX: 800-225-5614

Canada Office

9870 Boulevard du Golf
Anjou, Quebec Canada
Tel: 514-351-0330
FAX: 514-351-0458

Mexico Office

Av. Antonio Dovali Jaime No 70
Torre B Piso 9
La Fe, Santa Fe
Mexico, D.F. 01210
Tel: 52-55-5326-7100
FAX: 52-55-5236-7141

www.emhartamericas.com

© Emhart Teknologies

P218 & P218A (01/12)

EMHART[®]
TEKNOLOGIES

A StanleyBlack&Decker, Inc. Company



Request Info
1-800-453-1692
www.aboveboardelectronics.com