

METRIC SCREWS, BOLTS & THREADED ROD

ALL DIMENSIONS ARE IN MILLIMETERS



www.aboveboardelectronics.com
1-800-453-1692

SECTION
XII

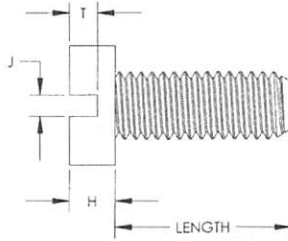
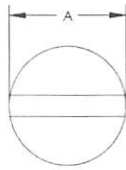

SCREW SIZE	A	H	J	T
M2 X 0.4	3.80	1.30	0.70	0.90
M2.5 X 0.45	4.50	1.60	0.80	1.00
M3 X 0.5	5.50	2.00	1.00	1.30
M3.5 X 0.6	6.00	2.40	1.10	1.40
M4 X 0.7	7.00	2.60	1.20	1.60
M5 X .08	8.50	3.30	1.50	2.00
M6 X 1.0	10.00	3.90	1.90	2.30
M8 X 1.25	13.00	5.00	2.30	2.80
M10 X 1.5	15.63	6.00	2.80	3.20

CHEESE SLOTTED

Molded in **Natural Nylon 6/6**

ITEM NUMBER	DESCRIPTION	ITEM NUMBER	DESCRIPTION
50M020040D004	M2 X .4 X 4MM Cheese Slot	50M040070D020	M4 X .7 X 20MM Cheese Slot
50M020040D005	M2 X .4 X 5MM Cheese Slot	50M040070D025	M4 X .7 X 25MM Cheese Slot
50M020040D006	M2 X .4 X 6MM Cheese Slot	50M040070D030	M4 X .7 X 30MM Cheese Slot
50M020040D008	M2 X .4 X 8MM Cheese Slot	50M040070D035	M4 X .7 X 35MM Cheese Slot
50M020040D010	M2 X .4 X 10MM Cheese Slot	50M040070D040	M4 X .7 X 40MM Cheese Slot
50M020040D012	M2 X .4 X 12MM Cheese Slot	50M050080D006	M5 X .8 X 6MM Cheese Slot
50M020040D016	M2 X .4 X 16MM Cheese Slot	50M050080D008	M5 X .8 X 8MM Cheese Slot
50M020040D020	M2 X .4 X 20MM Cheese Slot	50M050080D010	M5 X .8 X 10MM Cheese Slot
50M020040D025	M2 X .4 X 25MM Cheese Slot	50M050080D012	M5 X .8 X 12MM Cheese Slot
50M025045D004	M2.5 X .45 X 4MM Cheese Slot	50M050080D016	M5 X .8 X 16MM Cheese Slot
50M025045D005	M2.5 X .45 X 5MM Cheese Slot	50M050080D020	M5 X .8 X 20MM Cheese Slot
50M025045D006	M2.5 X .45 X 6MM Cheese Slot	50M050080D025	M5 X .8 X 25MM Cheese Slot
50M025045D008	M2.5 X .45 X 8MM Cheese Slot	50M050080D030	M5 X .8 X 30MM Cheese Slot
50M025045D010	M2.5 X .45 X 10MM Cheese Slot	50M050080D035	M5 X .8 X 35MM Cheese Slot
50M025045D012	M2.5 X .45 X 12MM Cheese Slot	50M050080D040	M5 X .8 X 40MM Cheese Slot
50M025045D016	M2.5 X .45 X 16MM Cheese Slot	50M060100D005	M6 X 1.0 X 5MM Cheese Slot
50M025045D020	M2.5 X .45 X 20MM Cheese Slot	50M060100D008	M6 X 1.0 X 8MM Cheese Slot
50M025045D025	M2.5 X .45 X 25MM Cheese Slot	50M060100D010	M6 X 1.0 X 10MM Cheese Slot
50M030050D004	M3 X .5 X 4MM Cheese Slot	50M060100D012	M6 X 1.0 X 12MM Cheese Slot
50M030050D005	M3 X .5 X 5MM Cheese Slot	50M060100D016	M6 X 1.0 X 16MM Cheese Slot
50M030050D006	M3 X .5 X 6MM Cheese Slot	50M060100D020	M6 X 1.0 X 20MM Cheese Slot
50M030050D008	M3 X .5 X 8MM Cheese Slot	50M060100D025	M6 X 1.0 X 25MM Cheese Slot
50M030050D010	M3 X .5 X 10MM Cheese Slot	50M060100D030	M6 X 1.0 X 30MM Cheese Slot
50M030050D012	M3 X .5 X 12MM Cheese Slot	50M060100D035	M6 X 1.0 X 35MM Cheese Slot
50M030050D014	M3 X .5 X 14MM Cheese Slot	50M060100D040	M6 X 1.0 X 40MM Cheese Slot
50M030050D016	M3 X .5 X 16MM Cheese Slot	50M060100D045	M6 X 1.0 X 45MM Cheese Slot
50M030050D020	M3 X .5 X 20MM Cheese Slot	50M060100D050	M6 X 1.0 X 50MM Cheese Slot
50M030050D025	M3 X .5 X 25MM Cheese Slot	50M060100D060	M6 X 1.0 X 60MM Cheese Slot
50M030050D030	M3 X .5 X 30MM Cheese Slot	50M060100D065	M6 X 1.0 X 65MM Cheese Slot
50M030050D035	M3 X .5 X 35MM Cheese Slot	50M060100D070	M6 X 1.0 X 70MM Cheese Slot
50M030050D042	M3 X .5 X 42MM Cheese Slot	50M060100D075	M6 X 1.0 X 75MM Cheese Slot
50M035060D005	M3.5 X .6 X 5MM Cheese Slot	50M080125D010	M8 X 1.25 X 10MM Cheese Slot
50M035060D006	M3.5 X .6 X 6MM Cheese Slot	50M080125D016	M8 X 1.25 X 16MM Cheese Slot
50M035060D008	M3.5 X .6 X 8MM Cheese Slot	50M080125D020	M8 X 1.25 X 20MM Cheese Slot
50M035060D010	M3.5 X .6 X 10MM Cheese Slot	50M080125D025	M8 X 1.25 X 25MM Cheese Slot
50M035060D012	M3.5 X .6 X 12MM Cheese Slot	50M080125D030	M8 X 1.25 X 30MM Cheese Slot
50M035060D016	M3.5 X .6 X 16MM Cheese Slot	50M080125D035	M8 X 1.25 X 35MM Cheese Slot
50M035060D020	M3.5 X .6 X 20MM Cheese Slot	50M080125D050	M8 X 1.25 X 50MM Cheese Slot
50M035060D025	M3.5 X .6 X 25MM Cheese Slot	50M080125D070	M8 X 1.25 X 70MM Cheese Slot
50M035060D035	M3.5 X .6 X 35MM Cheese Slot	50M100150D016	M10 X 1.50 X 16MM Cheese Slot
50M035060D042	M3.5 X .6 X 42MM Cheese Slot	50M100150D020	M10 X 1.50 X 20MM Cheese Slot
50M040070D004	M4 X .7 X 4MM Cheese Slot	50M100150D025	M10 X 1.50 X 25MM Cheese Slot
50M040070D006	M4 X .7 X 6MM Cheese Slot	50M100150D030	M10 X 1.50 X 30MM Cheese Slot
50M040070D008	M4 X .7 X 8MM Cheese Slot	50M100150D035	M10 X 1.50 X 35MM Cheese Slot
50M040070D010	M4 X .7 X 10MM Cheese Slot	50M100150D050	M10 X 1.50 X 50MM Cheese Slot
50M040070D012	M4 X .7 X 12MM Cheese Slot	50M100150D060	M10 X 1.50 X 60MM Cheese Slot
50M040070D016	M4 X .7 X 16MM Cheese Slot		

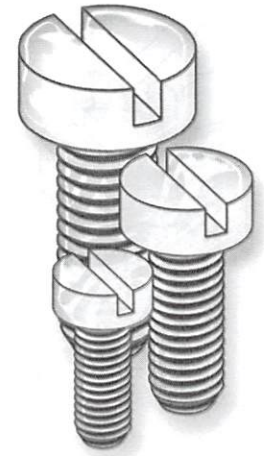

METRIC SCREWS, BOLTS & THREADED ROD

SECTION
XII

HEX SLOTTED

Molded in **Natural Nylon 6/6**

SCREW SIZE	A	W	H	J	T
M2	3.02 - 3.20	3.38	min. 1.3 - 1.6	.60	.46
M2.5	3.82 - 4.00	4.28	min. 1.8 - 2.1	.80	.99
M3	4.82 - 5.00	5.40	min. 2.0 - 2.3	.99	1.30
M3.5	5.32 - 5.50	5.96	min. 2.3 - 2.6	1.20	1.28
M4	6.78 - 7.00	7.59	min. 2.6 - 3.0	1.24	1.28
M5	7.78 - 8.00	8.71	min. 3.3 - 3.8	1.30	1.40
M6	9.78 - 10.00	10.95	min. 4.1 - 4.7	1.70	2.24
M8	12.73 - 13.00	14.26	min. 5.2 - 6.0	2.15	2.27
M10	15.73 - 16.00	17.62	min. 6.5 - 7.5	2.38	2.90

ALL DIMENSIONS ARE IN MILLIMETERS

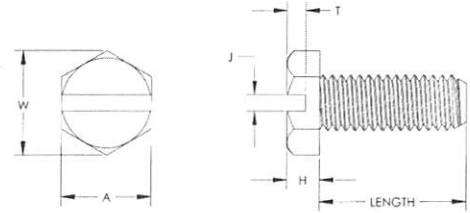

www.aboveboardelectronics.com
1-800-453-1692

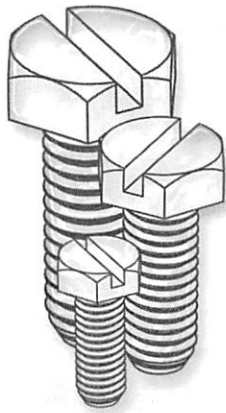

ITEM NUMBER	DESCRIPTION
50M020040K004	M2 X .4 X 4MM HEX SL
50M020040K005	M2 X .4 X 5MM HEX SL
50M020040K006	M2 X .4 X 6MM HEX SL
50M020040K008	M2 X .4 X 8MM HEX SL
50M020040K010	M2 X .4 X 10MM HEX SL
50M020040K012	M2 X .4 X 12MM HEX SL
50M020040K016	M2 X .4 X 16MM HEX SL
50M020040K020	M2 X .4 X 20MM HEX SL
50M020040K025	M2 X .4 X 25MM HEX SL
50M025045K004	M2.5 X .45 X 4MM HEX SL
50M025045K005	M2.5 X .45 X 5MM HEX SL
50M025045K006	M2.5 X .45 X 6MM HEX SL
50M025045K008	M2.5 X .45 X 8MM HEX SL
50M025045K010	M2.5 X .45 X 10MM HEX SL
50M025045K012	M2.5 X .45 X 12MM HEX SL
50M025045K016	M2.5 X .45 X 16MM HEX SL
50M025045K020	M2.5 X .45 X 20MM HEX SL
50M025045K025	M2.5 X .45 X 25MM HEX SL
50M030050K004	M3 X .5 X 4MM HEX SL
50M030050K005	M3 X .5 X 5MM HEX SL
50M030050K006	M3 X .5 X 6MM HEX SL
50M030050K008	M3 X .5 X 8MM HEX SL
50M030050K010	M3 X .5 X 10MM HEX SL
50M030050K012	M3 X .5 X 12MM HEX SL
50M030050K016	M3 X .5 X 16MM HEX SL
50M030050K020	M3 X .5 X 20MM HEX SL
50M030050K025	M3 X .5 X 25MM HEX SL
50M030050K030	M3 X .5 X 30MM HEX SL
50M030050K035	M3 X .5 X 35MM HEX SL
50M030050K042	M3 X .5 X 42MM HEX SL
50M035060K005	M3.5 X .6 X 5MM HEX SL
50M035060K006	M3.5 X .6 X 6MM HEX SL
50M035060K007	M3.5 X .6 X 7MM HEX SL
50M035060K008	M3.5 X .6 X 8MM HEX SL
50M035060K010	M3.5 X .6 X 10MM HEX SL
50M035060K012	M3.5 X .6 X 12MM HEX SL
50M035060K016	M3.5 X .6 X 16MM HEX SL
50M035060K020	M3.5 X .6 X 20MM HEX SL
50M035060K025	M3.5 X .6 X 25MM HEX SL
50M035060K035	M3.5 X .6 X 35MM HEX SL
50M035060K042	M3.5 X .6 X 42MM HEX SL
50M040070K006	M4 X .7 X 6MM HEX SL
50M040070K008	M4 X .7 X 8MM HEX SL
50M040070K010	M4 X .7 X 10MM HEX SL
50M040070K012	M4 X .7 X 12MM HEX SL
50M040070K016	M4 X .7 X 16MM HEX SL

ITEM NUMBER	DESCRIPTION
50M040070K020	M4 X .7 X 20MM HEX SL
50M040070K025	M4 X .7 X 25MM HEX SL
50M040070K030	M4 X .7 X 30MM HEX SL
50M040070K035	M4 X .7 X 35MM HEX SL
50M040070K040	M4 X .7 X 40MM HEX SL
50M050080K006	M5 X .8 X 6MM HEX SL
50M050080K008	M5 X .8 X 8MM HEX SL
50M050080K010	M5 X .8 X 10MM HEX SL
50M050080K012	M5 X .8 X 12MM HEX SL
50M050080K016	M5 X .8 X 16MM HEX SL
50M050080K020	M5 X .8 X 20MM HEX SL
50M050080K025	M5 X .8 X 25MM HEX SL
50M050080K030	M5 X .8 X 30MM HEX SL
50M050080K035	M5 X .8 X 35MM HEX SL
50M050080K040	M5 X .8 X 40MM HEX SL
50M060100K005	M6 X 1.00 X 5MM HEX SL
50M060100K008	M6 X 1.00 X 8MM HEX SL
50M060100K010	M6 X 1.00 X 10MM HEX SL
50M060100K012	M6 X 1.00 X 12MM HEX SL
50M060100K016	M6 X 1.00 X 16MM HEX SL
50M060100K020	M6 X 1.00 X 20MM HEX SL
50M060100K025	M6 X 1.00 X 25MM HEX SL
50M060100K030	M6 X 1.00 X 30MM HEX SL
50M060100K035	M6 X 1.00 X 35MM HEX SL
50M060100K040	M6 X 1.00 X 40MM HEX SL
50M060100K045	M6 X 1.00 X 45MM HEX SL
50M060100K050	M6 X 1.00 X 50MM HEX SL
50M060100K060	M6 X 1.00 X 60MM HEX SL
50M060100K070	M6 X 1.00 X 70MM HEX SL
50M060100K075	M6 X 1.00 X 75MM HEX SL
50M080125K010	M8 X 1.25 X 10MM HEX SL
50M080125K016	M8 X 1.25 X 16MM HEX SL
50M080125K020	M8 X 1.25 X 20MM HEX SL
50M080125K025	M8 X 1.25 X 25MM HEX SL
50M080125K030	M8 X 1.25 X 30MM HEX SL
50M080125K035	M8 X 1.25 X 35MM HEX SL
50M080125K040	M8 X 1.25 X 40MM HEX SL
50M080125K050	M8 X 1.25 X 50MM HEX SL
50M080125K070	M8 X 1.25 X 70MM HEX SL
50M100150K016	M10 X 1.50 X 16MM HEX SL
50M100150K020	M10 X 1.50 X 20MM HEX SL
50M100150K025	M10 X 1.50 X 25MM HEX SL
50M100150K030	M10 X 1.50 X 30MM HEX SL
50M100150K035	M10 X 1.50 X 35MM HEX SL
50M100150K050	M10 X 1.50 X 50MM HEX SL
50M100150K060	M10 X 1.50 X 60MM HEX SL



METRIC SCREWS, BOLTS & THREADED ROD

ALL DIMENSIONS ARE IN MILLIMETERS

HEX

Molded in **Natural Nylon 6/6**

ITEM NUMBER	DESCRIPTION
50M020040J004	M2 X .4 X 4MM HEX
50M020040J005	M2 X .4 X 5MM HEX
50M020040J006	M2 X .4 X 6MM HEX
50M020040J008	M2 X .4 X 8MM HEX
50M020040J010	M2 X .4 X 10MM HEX
50M020040J012	M2 X .4 X 12MM HEX
50M020040J016	M2 X .4 X 16MM HEX
50M020040J020	M2 X .4 X 20MM HEX
50M020040J025	M2 X .4 X 25MM HEX
50M025045J004	M2.5 X .45 X 4MM HEX
50M025045J005	M2.5 X .45 X 5MM HEX
50M025045J006	M2.5 X .45 X 6MM HEX
50M025045J008	M2.5 X .45 X 8MM HEX
50M025045J010	M2.5 X .45 X 10MM HEX
50M025045J012	M2.5 X .45 X 12MM HEX
50M025045J016	M2.5 X .45 X 16MM HEX
50M025045J020	M2.5 X .45 X 20MM HEX
50M025045J025	M2.5 X .45 X 25MM HEX
50M030050J004	M3 X .5 X 4MM HEX
50M030050J005	M3 X .5 X 5MM HEX
50M030050J006	M3 X .5 X 6MM HEX
50M030050J008	M3 X .5 X 8MM HEX
50M030050J010	M3 X .5 X 10MM HEX
50M030050J012	M3 X .5 X 12MM HEX
50M030050J016	M3 X .5 X 16MM HEX
50M030050J020	M3 X .5 X 20MM HEX
50M030050J025	M3 X .5 X 25MM HEX
50M030050J030	M3 X .5 X 30MM HEX
50M030050J035	M3 X .5 X 35MM HEX
50M030050J042	M3 X .5 X 42MM HEX
50M035060J005	M3.5 X .6 X 5MM HEX
50M035060J006	M3.5 X .6 X 6MM HEX
50M035060J007	M3.5 X .6 X 7MM HEX
50M035060J008	M3.5 X .6 X 8MM HEX
50M035060J010	M3.5 X .6 X 10MM HEX
50M035060J012	M3.5 X .6 X 12MM HEX
50M035060J016	M3.5 X .6 X 16MM HEX
50M035060J020	M3.5 X .6 X 20MM HEX
50M035060J025	M3.5 X .6 X 25MM HEX
50M035060J035	M3.5 X .6 X 35MM HEX
50M035060J042	M3.5 X .6 X 42MM HEX
50M040070J006	M4 X .7 X 6MM HEX
50M040070J008	M4 X .7 X 8MM HEX
50M040070J010	M4 X .7 X 10MM HEX
50M040070J012	M4 X .7 X 12MM HEX
50M040070J016	M4 X .7 X 16MM HEX
50M040070J020	M4 X .7 X 20MM HEX
50M040070J025	M4 X .7 X 25MM HEX
50M040070J030	M4 X .7 X 30MM HEX
50M040070J035	M4 X .7 X 35MM HEX
50M040070J040	M4 X .7 X 40MM HEX
50M050080J006	M5 X .8 X 6MM HEX

ITEM NUMBER	DESCRIPTION
50M050080J008	M5 X .8 8MM HEX
50M050080J010	M5 X .8 10MM HEX
50M050080J012	M5 X .8 12MM HEX
50M050080J014	M5 X .8 14MM HEX
50M050080J016	M5 X .8 16MM HEX
50M050080J020	M5 X .8 20MM HEX
50M050080J025	M5 X .8 25MM HEX
50M050080J030	M5 X .8 30MM HEX
50M050080J035	M5 X .8 35MM HEX
50M050080J040	M5 X .8 40MM HEX
50M050080J070	M5 X .8 70MM HEX
50M060100J005	M6 X 1.00 5MM HEX
50M060100J008	M6 X 1.00 8MM HEX
50M060100J010	M6 X 1.00 10MM HEX
50M060100J012	M6 X 1.00 12MM HEX
50M060100J016	M6 X 1.00 16MM HEX
50M060100J020	M6 X 1.00 20MM HEX
50M060100J025	M6 X 1.00 25MM HEX
50M060100J030	M6 X 1.00 30MM HEX
50M060100J035	M6 X 1.00 35MM HEX
50M060100J040	M6 X 1.00 40MM HEX
50M060100J045	M6 X 1.00 45MM HEX
50M060100J050	M6 X 1.00 50MM HEX
50M060100J060	M6 X 1.00 60MM HEX
50M060100J070	M6 X 1.00 70MM HEX
50M060100J075	M6 X 1.00 75MM HEX
50M080125J006	M8 X 1.25 6MM HEX
50M080125J010	M8 X 1.25 10MM HEX
50M080125J016	M8 X 1.25 16MM HEX
50M080125J020	M8 X 1.25 20MM HEX
50M080125J025	M8 X 1.25 25MM HEX
50M080125J030	M8 X 1.25 30MM HEX
50M080125J035	M8 X 1.25 35MM HEX
50M080125J040	M8 X 1.25 40MM HEX
50M080125J050	M8 X 1.25 50MM HEX
50M080125J070	M8 X 1.25 70MM HEX
50M080125J080	M8 X 1.25 80MM HEX
50M100150J016	M10 X 1.50 16MM HEX
50M100150J020	M10 X 1.50 20MM HEX
50M100150J025	M10 X 1.50 25MM HEX
50M100150J030	M10 X 1.50 30MM HEX
50M100150J035	M10 X 1.50 35MM HEX
50M100150J050	M10 X 1.50 50MM HEX
50M100150J060	M10 X 1.50 60MM HEX
50M120125J012	M12 X 1.25 12MM HEX
50M120175J020	M12 X 1.75 20MM HEX
50M120175J025	M12 X 1.75 25MM HEX
50M120175J030	M12 X 1.75 30MM HEX
50M120175J035	M12 X 1.75 35MM HEX
50M120175J040	M12 X 1.75 40MM HEX
50M120175J050	M12 X 1.75 50MM HEX

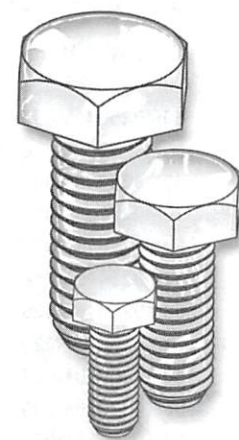
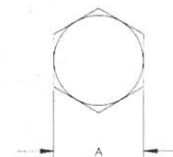
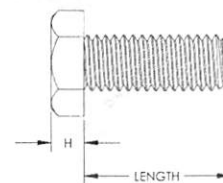

SECTION
XII

SCREW SIZE	A	H	W
M2	3.02 - 3.20	1.3 - 1.6	3.38 min.
M2.5	3.82 - 4.00	1.8 - 2.1	4.28 min.
M3	4.82 - 5.00	2.0 - 2.3	5.40 min.
M3.5	5.32 - 5.50	2.3 - 2.6	5.96 min.
M4	6.78 - 7.00	2.6 - 3.0	7.59 min.
M5	7.78 - 8.00	3.3 - 3.8	8.71 min.
M6	9.78 - 10.00	4.1 - 4.7	10.95 min.
M8	12.73 - 13.00	5.2 - 6.0	14.26 min.
M10	15.73 - 16.00	6.5 - 7.5	17.62 min.
M12	17.73 - 18.00	7.8 - 9.0	19.86 min.



METRIC SCREWS, BOLTS & THREADED ROD

SECTION
XII

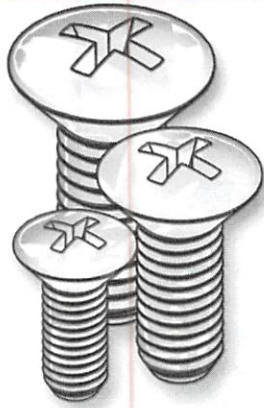

ALL DIMENSIONS ARE IN MILLIMETERS

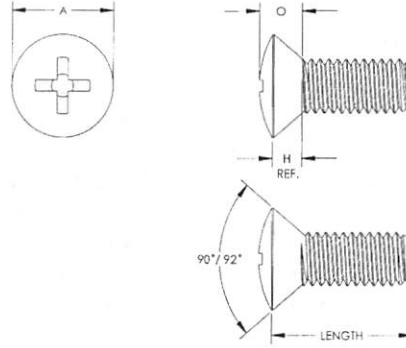

OVAL PHILLIPS

Molded in **Natural Nylon 6/6**

ITEM NUMBER	----- DESCRIPTION -----
50M025045M004	M2.5 X .45 X 4MM Oval Phil
50M025045M005	M2.5 X .45 X 5MM Oval Phil
50M025045M006	M2.5 X .45 X 6MM Oval Phil
50M025045M008	M2.5 X .45 X 8MM Oval Phil
50M025045M010	M2.5 X .45 X 10MM Oval Phil
50M025045M012	M2.5 X .45 X 12MM Oval Phil
50M025045M016	M2.5 X .45 X 16MM Oval Phil
50M025045M020	M2.5 X .45 X 20MM Oval Phil
50M025045M025	M2.5 X .45 X 25MM Oval Phil
50M030050M005	M3 X .5 X 5MM Oval Phil
50M030050M006	M3 X .5 X 6MM Oval Phil
50M030050M008	M3 X .5 X 8MM Oval Phil
50M030050M010	M3 X .5 X 10MM Oval Phil
50M030050M012	M3 X .5 X 12MM Oval Phil
50M030050M016	M3 X .5 X 16MM Oval Phil
50M030050M020	M3 X .5 X 20MM Oval Phil
50M030050M025	M3 X .5 X 25MM Oval Phil
50M035060M005	M3.5 X .6 X 5MM Oval Phil
50M035060M006	M3.5 X .6 X 6MM Oval Phil
50M035060M008	M3.5 X .6 X 8MM Oval Phil
50M035060M010	M3.5 X .6 X 10MM Oval Phil
50M035060M012	M3.5 X .6 X 12MM Oval Phil
50M035060M016	M3.5 X .6 X 16MM Oval Phil
50M035060M020	M3.5 X .6 X 20MM Oval Phil
50M035060M025	M3.5 X .6 X 25MM Oval Phil
50M035060M035	M3.5 X .6 X 35MM Oval Phil
50M040070M006	M4 X .7 X 6MM Oval Phil
50M040070M008	M4 X .7 X 8MM Oval Phil
50M040070M010	M4 X .7 X 10MM Oval Phil
50M040070M012	M4 X .7 X 12MM Oval Phil

ITEM NUMBER	----- DESCRIPTION -----
50M040070M016	M4 X .7 X 16MM Oval Phil
50M040070M020	M4 X .7 X 20MM Oval Phil
50M040070M025	M4 X .7 X 25MM Oval Phil
50M050080M006	M5 X .8 X 6MM Oval Phil
50M050080M008	M5 X .8 X 8MM Oval Phil
50M050080M010	M5 X .8 X 10MM Oval Phil
50M050080M012	M5 X .8 X 12MM Oval Phil
50M050080M016	M5 X .8 X 16MM Oval Phil
50M050080M020	M5 X .8 X 20MM Oval Phil
50M050080M025	M5 X .8 X 25MM Oval Phil
50M050080M030	M5 X .8 X 30MM Oval Phil
50M050080M040	M5 X .8 X 40MM Oval Phil
50M060100M008	M6 X 1.00 X 8MM Oval Phil
50M060100M010	M6 X 1.00 X 10MM Oval Phil
50M060100M012	M6 X 1.00 X 12MM Oval Phil
50M060100M016	M6 X 1.00 X 16MM Oval Phil
50M060100M020	M6 X 1.00 X 20MM Oval Phil
50M060100M025	M6 X 1.00 X 25MM Oval Phil
50M060100M035	M6 X 1.00 X 35MM Oval Phil
50M060100M045	M6 X 1.00 X 45MM Oval Phil
50M080125M010	M8 X 1.25 X 10MM Oval Phil
50M080125M016	M8 X 1.25 X 16MM Oval Phil
50M080125M020	M8 X 1.25 X 20MM Oval Phil
50M080125M025	M8 X 1.25 X 25MM Oval Phil
50M080125M030	M8 X 1.25 X 30MM Oval Phil
50M080125M050	M8 X 1.25 X 50MM Oval Phil
50M100150M020	M10 X 1.5 X 20MM Oval Phil
50M100150M025	M10 X 1.5 X 25MM Oval Phil
50M100150M035	M10 X 1.5 X 35MM Oval Phil

THREAD SIZE	A	H	O
M2 X 0.4	3.5 - 4.4	1.2 max ref.	1.7 max
M2.5 X 0.45	4.4 - 5.5	1.5 max ref.	2.1 max
M3 X 0.5	5.2 - 6.3	1.7 max ref.	2.4 max
M3.5 X 0.6	6.9 - 8.2	2.3 max ref.	3.1 max
M4 X 0.7	8.0 - 9.4	2.7 max ref.	3.7 max
M5 X 0.8	8.9 - 10.4	2.7 max ref.	3.9 max
M6 X 1	10.9 - 12.6	3.3 max ref.	4.7 max
M8 X 1.25	15.4 - 17.3	4.6 max ref.	6.6 max
M10 X 1.5	17.8 - 20.0	5.0 max ref.	7.3 max



METRIC SCREWS, BOLTS & THREADED ROD

ALL DIMENSIONS ARE IN MILLIMETERS

SECTION
XII

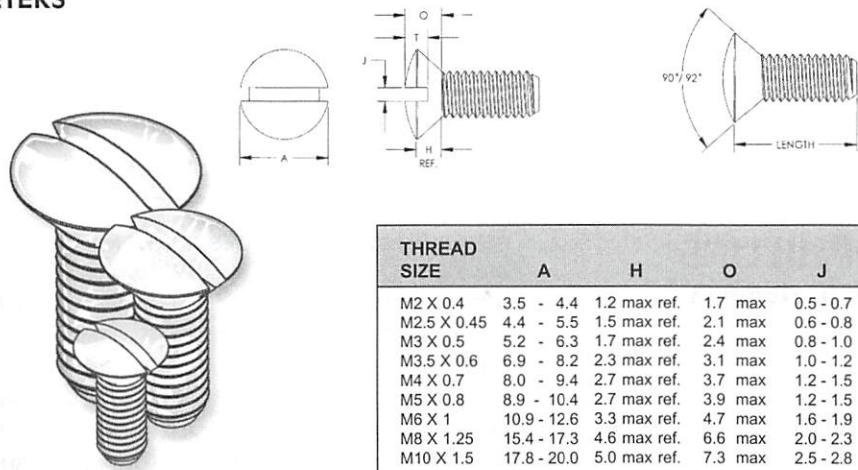

OVAL SLOTTED

Molded in **Natural Nylon 6/6**

THREAD SIZE	A	H	O	J	T
M2 X 0.4	3.5 - 4.4	1.2 max ref.	1.7 max	0.5 - 0.7	0.8 - 1.0
M2.5 X 0.45	4.4 - 5.5	1.5 max ref.	2.1 max	0.6 - 0.8	1.0 - 1.2
M3 X 0.5	5.2 - 6.3	1.7 max ref.	2.4 max	0.8 - 1.0	1.2 - 1.5
M3.5 X 0.6	6.9 - 8.2	2.3 max ref.	3.1 max	1.0 - 1.2	1.4 - 1.7
M4 X 0.7	8.0 - 9.4	2.7 max ref.	3.7 max	1.2 - 1.5	1.6 - 1.9
M5 X 0.8	8.9 - 10.4	2.7 max ref.	3.9 max	1.2 - 1.5	2.0 - 2.4
M6 X 1	10.9 - 12.6	3.3 max ref.	4.7 max	1.6 - 1.9	2.4 - 2.8
M8 X 1.25	15.4 - 17.3	4.6 max ref.	6.6 max	2.0 - 2.3	3.2 - 3.7
M10 X 1.5	17.8 - 20.0	5.0 max ref.	7.3 max	2.5 - 2.8	3.8 - 4.4

ITEM NUMBER	DESCRIPTION	ITEM NUMBER	DESCRIPTION
50M020040L004	M2 X .4 X 4MM Oval Slot	50M040070L012	M4 X .7 X 12MM Oval Slot
50M020040L005	M2 X .4 X 5MM Oval Slot	50M040070L015	M4 X .7 X 15MM Oval Slot
50M020040L006	M2 X .4 X 6MM Oval Slot	50M040070L016	M4 X .7 X 16MM Oval Slot
50M020040L008	M2 X .4 X 8MM Oval Slot	50M040070L020	M4 X .7 X 20MM Oval Slot
50M020040L010	M2 X .4 X 10MM Oval Slot	50M040070L025	M4 X .7 X 25MM Oval Slot
50M020040L011	M2 X .4 X 11MM Oval Slot	50M040070L030	M4 X .7 X 30MM Oval Slot
50M020040L012	M2 X .4 X 12MM Oval Slot	50M040070L035	M4 X .7 X 35MM Oval Slot
50M020040L016	M2 X .4 X 16MM Oval Slot	50M050080L006	M5 X .8 X 6MM Oval Slot
50M020040L025	M2 X .4 X 25MM Oval Slot	50M050080L008	M5 X .8 X 8MM Oval Slot
50M025045L004	M2.5 X .45 X 4MM Oval Slot	50M050080L010	M5 X .8 X 10MM Oval Slot
50M025045L005	M2.5 X .45 X 5MM Oval Slot	50M050080L012	M5 X .8 X 12MM Oval Slot
50M025045L006	M2.5 X .45 X 6MM Oval Slot	50M050080L015	M5 X .8 X 15MM Oval Slot
50M025045L008	M2.5 X .45 X 8MM Oval Slot	50M050080L016	M5 X .8 X 16MM Oval Slot
50M025045L010	M2.5 X .45 X 10MM Oval Slot	50M050080L020	M5 X .8 X 20MM Oval Slot
50M025045L012	M2.5 X .45 X 12MM Oval Slot	50M050080L025	M5 X .8 X 25MM Oval Slot
50M025045L016	M2.5 X .45 X 16MM Oval Slot	50M050080L030	M5 X .8 X 30MM Oval Slot
50M025045L020	M2.5 X .45 X 20MM Oval Slot	50M050080L035	M5 X .8 X 35MM Oval Slot
50M025045L025	M2.5 X .5 X 25MM Oval Slot	50M050080L040	M5 X .8 X 40MM Oval Slot
50M030050L005	M3 X .5 X 5MM Oval Slot	50M060100L008	M6 X 1.00 X 8MM Oval Slot
50M030050L006	M3 X .5 X 6MM Oval Slot	50M060100L010	M6 X 1.00 X 10MM Oval Slot
50M030050L008	M3 X .5 X 8MM Oval Slot	50M060100L012	M6 X 1.00 X 12MM Oval Slot
50M030050L010	M3 X .5 X 10MM Oval Slot	50M060100L016	M6 X 1.00 X 16MM Oval Slot
50M030050L012	M3 X .5 X 12MM Oval Slot	50M060100L020	M6 X 1.00 X 20MM Oval Slot
50M030050L015	M3 X .5 X 15MM Oval Slot	50M060100L025	M6 X 1.00 X 25MM Oval Slot
50M030050L016	M3 X .5 X 16MM Oval Slot	50M060100L035	M6 X 1.00 X 35MM Oval Slot
50M030050L020	M3 X .5 X 20MM Oval Slot	50M060100L040	M6 X 1.00 X 40MM Oval Slot
50M030050L025	M3 X .5 X 25MM Oval Slot	50M060100L045	M6 X 1.00 X 45MM Oval Slot
50M030050L030	M3 X .5 X 30MM Oval Slot	50M060100L050	M6 X 1.00 X 50MM Oval Slot
50M030050L042	M3 X .5 X 42MM Oval Slot	50M080125L020	M8 X 1.25 X 20MM Oval Slot
50M035060L005	M3.5 X .6 X 5MM Oval Slot	50M080125L030	M8 X 1.25 X 30MM Oval Slot
50M035060L006	M3.5 X .6 X 6MM Oval Slot	50M080125L050	M8 X 1.25 X 50MM Oval Slot
50M035060L008	M3.5 X .6 X 8MM Oval Slot	50M100150L020	M10 X 1.50 X 20MM Oval Slot
50M035060L010	M3.5 X .6 X 10MM Oval Slot	50M100150L025	M10 X 1.50 X 25MM Oval Slot
50M035060L016	M3.5 X .6 X 16MM Oval Slot	50M100150L030	M10 X 1.50 X 30MM Oval Slot
50M035060L020	M3.5 X .6 X 20MM Oval Slot	50M100150L035	M10 X 1.50 X 35MM Oval Slot
50M035060L025	M3.5 X .6 X 25MM Oval Slot	50M100150L060	M10 X 1.50 X 60MM Oval Slot
50M035060L035	M3.5 X .6 X 35MM Oval Slot		
50M040070L006	M4 X .7 X 6MM Oval Slot		
50M040070L008	M4 X .7 X 8MM Oval Slot		
50M040070L010	M4 X .7 X 10MM Oval Slot		

METRIC SCREWS, BOLTS & THREADED ROD

SECTION
XII

ALL DIMENSIONS ARE IN MILLIMETERS

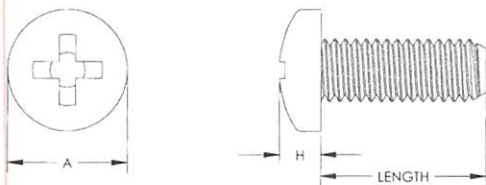

PAN PHILLIPS

Molded in **Natural Nylon 6/6**

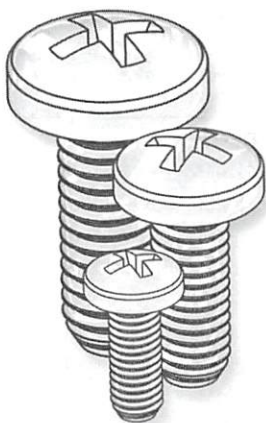

THREAD SIZE	A	H
M2	3.7 - 4.0	1.4 - 1.6
M2.5	4.7 - 5.0	1.9 - 2.1
M3	5.3 - 5.6	2.2 - 2.4
M3.5	6.6 - 7.0	2.3 - 2.6
M4	7.6 - 8.0	2.8 - 3.1
M5	9.1 - 9.5	3.4 - 3.7
M6	11.5 - 12.0	4.3 - 4.6
M8	15.5 - 16.0	5.6 - 6.0
M10	19.4 - 20.0	7.1 - 7.5

ITEM NUMBER ----- DESCRIPTION -----

50M020040P004	M2	X .4	X 4MM	Pan Phil
50M020040P005	M2	X .4	X 5MM	Pan Phil
50M020040P006	M2	X .4	X 6MM	Pan Phil
50M020040P008	M2	X .4	X 8MM	Pan Phil
50M020040P010	M2	X .4	X 10MM	Pan Phil
50M020040P012	M2	X .4	X 12MM	Pan Phil
50M020040P016	M2	X .4	X 16MM	Pan Phil
50M020040P020	M2	X .4	X 20MM	Pan Phil
50M020040P025	M2	X .4	X 25MM	Pan Phil
50M025045P004	M2.5	X .45	X 4MM	Pan Phil
50M025045P005	M2.5	X .45	X 5MM	Pan Phil
50M025045P006	M2.5	X .45	X 6MM	Pan Phil
50M025045P008	M2.5	X .45	X 8MM	Pan Phil
50M025045P010	M2.5	X .45	X 10MM	Pan Phil
50M025045P012	M2.5	X .45	X 12MM	Pan Phil
50M025045P016	M2.5	X .45	X 16MM	Pan Phil
50M025045P020	M2.5	X .45	X 20MM	Pan Phil
50M025045P025	M2.5	X .45	X 25MM	Pan Phil
50M030050 P003	M3	X .5	X 3MM	Pan Phil
50M030050P004	M3	X .5	X 4MM	Pan Phil
50M030050P005	M3	X .5	X 5MM	Pan Phil
50M030050P006	M3	X .5	X 6MM	Pan Phil
50M030050P008	M3	X .5	X 8MM	Pan Phil
50M030050P010	M3	X .5	X 10MM	Pan Phil
50M030050P012	M3	X .5	X 12MM	Pan Phil
50M030050P016	M3	X .5	X 16MM	Pan Phil
50M030050P020	M3	X .5	X 20MM	Pan Phil
50M030050P025	M3	X .5	X 25MM	Pan Phil
50M030050P030	M3	X .5	X 30MM	Pan Phil
50M030050P035	M3	X .5	X 35MM	Pan Phil
50M030050P042	M3	X .5	X 42MM	Pan Phil
50M035060P005	M3.5	X .6	X 5MM	Pan Phil
50M035060P006	M3.5	X .6	X 6MM	Pan Phil
50M035060P007	M3.5	X .6	X 7MM	Pan Phil
50M035060P008	M3.5	X .6	X 8MM	Pan Phil
50M035060P010	M3.5	X .6	X 10MM	Pan Phil
50M035060P012	M3.5	X .6	X 12MM	Pan Phil
50M035060P016	M3.5	X .6	X 16MM	Pan Phil
50M035060P020	M3.5	X .6	X 20MM	Pan Phil
50M035060P025	M3.5	X .6	X 25MM	Pan Phil
50M035060P035	M3.5	X .6	X 35MM	Pan Phil
50M035060P042	M3.5	X .6	X 42MM	Pan Phil
50M040070P003	M4	X .7	X 3MM	Pan Phil
50M040070P006	M4	X .7	X 6MM	Pan Phil
50M040070P008	M4	X .7	X 8MM	Pan Phil
50M040070P010	M4	X .7	X 10MM	Pan Phil
50M040070P012	M4	X .7	X 12MM	Pan Phil
50M040070P016	M4	X .7	X 16MM	Pan Phil
50M040070P020	M4	X .7	X 20MM	Pan Phil

ITEM NUMBER ----- DESCRIPTION -----

50M040070P025	M4	X .7	X 25MM	Pan Phil
50M040070P030	M4	X .7	X 30MM	Pan Phil
50M040070P035	M4	X .7	X 35MM	Pan Phil
50M040070P040	M4	X .7	X 40MM	Pan Phil
50M050080P006	M5	X .8	X 6MM	Pan Phil
50M050080P008	M5	X .8	X 8MM	Pan Phil
50M050080P010	M5	X .8	X 10MM	Pan Phil
50M050080P012	M5	X .8	X 12MM	Pan Phil
50M050080P015	M5	X .8	X 15MM	Pan Phil
50M050080P016	M5	X .8	X 16MM	Pan Phil
50M050080P020	M5	X .8	X 20MM	Pan Phil
50M050080P025	M5	X .8	X 25MM	Pan Phil
50M050080P030	M5	X .8	X 30MM	Pan Phil
50M050080P035	M5	X .8	X 35MM	Pan Phil
50M050080P040	M5	X .8	X 40MM	Pan Phil
50M060100P005	M6	X 1.00	X 5MM	Pan Phil
50M060100P008	M6	X 1.00	X 8MM	Pan Phil
50M060100P010	M6	X 1.00	X 10MM	Pan Phil
50M060100P012	M6	X 1.00	X 12MM	Pan Phil
50M060100P016	M6	X 1.00	X 16MM	Pan Phil
50M060100P020	M6	X 1.00	X 20MM	Pan Phil
50M060100P022	M6	X 1.00	X 22MM	Pan Phil
50M060100P025	M6	X 1.00	X 25MM	Pan Phil
50M060100P030	M6	X 1.00	X 30MM	Pan Phil
50M060100P035	M6	X 1.00	X 35MM	Pan Phil
50M060100P040	M6	X 1.00	X 40MM	Pan Phil
50M060100P045	M6	X 1.00	X 45MM	Pan Phil
50M060100P050	M6	X 1.00	X 50MM	Pan Phil
50M060100P060	M6	X 1.00	X 60MM	Pan Phil
50M060100P070	M6	X 1.00	X 70MM	Pan Phil
50M060100P075	M6	X 1.00	X 75MM	Pan Phil
50M080125P010	M8	X 1.25	X 10MM	Pan Phil
50M080125P016	M8	X 1.25	X 16MM	Pan Phil
50M080125P020	M8	X 1.25	X 20MM	Pan Phil
50M080125P025	M8	X 1.25	X 25MM	Pan Phil
50M080125P030	M8	X 1.25	X 30MM	Pan Phil
50M080125P035	M8	X 1.25	X 35MM	Pan Phil
50M080125P050	M8	X 1.25	X 50MM	Pan Phil
50M080125P070	M8	X 1.25	X 70MM	Pan Phil
50M100150P013	M10	X 1.50	X 13MM	Pan Phil
50M100150P016	M10	X 1.50	X 16MM	Pan Phil
50M100150P019	M10	X 1.50	X 19MM	Pan Phil
50M100150P020	M10	X 1.50	X 20MM	Pan Phil
50M100150P025	M10	X 1.50	X 25MM	Pan Phil
50M100150P030	M10	X 1.50	X 30MM	Pan Phil
50M100150P035	M10	X 1.50	X 35MM	Pan Phil
50M100150P050	M10	X 1.50	X 50MM	Pan Phil
50M100150P060	M10	X 1.50	X 60MM	Pan Phil



METRIC SCREWS, BOLTS & THREADED ROD

SECTION
XII

ALL DIMENSIONS ARE IN MILLIMETERS



www.aboveboardelectronics.com
1-800-453-1692

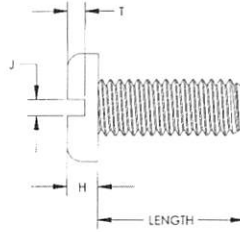
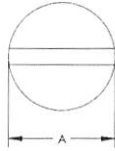

ITEM NUMBER	----- DESCRIPTION -----	ITEM NUMBER	----- DESCRIPTION -----
50M020040N004	M2 X .4 X 4MM Pan Slot	50M040070N025	M4 X .7 X 25MM Pan Slot
50M020040N003	M2 X .4 X 3MM Pan Slot	50M040070N030	M4 X .7 X 30MM Pan Slot
50M020040N005	M2 X .4 X 5MM Pan Slot	50M040070N035	M4 X .7 X 35MM Pan Slot
50M020040N006	M2 X .4 X 6MM Pan Slot	50M040070N040	M4 X .7 X 40MM Pan Slot
50M020040N008	M2 X .4 X 8MM Pan Slot	50M050080N006	M5 X .8 X 6MM Pan Slot
50M020040N010	M2 X .4 X 10MM Pan Slot	50M050080N008	M5 X .8 X 8MM Pan Slot
50M020040N012	M2 X .4 X 12MM Pan Slot	50M050080N010	M5 X .8 X 10MM Pan Slot
50M020040N016	M2 X .4 X 16MM Pan Slot	50M050080N012	M5 X .8 X 12MM Pan Slot
50M020040N020	M2 X .4 X 20MM Pan Slot	50M050080N015	M5 X .8 X 15MM Pan Slot
50M020040N025	M2 X .4 X 25MM Pan Slot	50M050080N016	M5 X .8 X 16MM Pan Slot
50M025045N004	M2.5 X .45 X 4MM Pan Slot	50M050080N020	M5 X .8 X 20MM Pan Slot
50M025045N005	M2.5 X .45 X 5MM Pan Slot	50M050080N025	M5 X .8 X 25MM Pan Slot
50M025045N006	M2.5 X .45 X 6MM Pan Slot	50M050080N030	M5 X .8 X 30MM Pan Slot
50M025045N008	M2.5 X .45 X 8MM Pan Slot	50M050080N035	M5 X .8 X 35MM Pan Slot
50M025045N010	M2.5 X .45 X 10MM Pan Slot	50M050080N040	M5 X .8 X 40MM Pan Slot
50M025045N012	M2.5 X .45 X 12MM Pan Slot	50M060100N005	M6 X 1.00 X 5MM Pan Slot
50M025045N016	M2.5 X .45 X 16MM Pan Slot	50M060100N008	M6 X 1.00 X 8MM Pan Slot
50M025045N020	M2.5 X .45 X 20MM Pan Slot	50M060100N010	M6 X 1.00 X 10MM Pan Slot
50M025045N025	M2.5 X .45 X 25MM Pan Slot	50M060100N012	M6 X 1.00 X 12MM Pan Slot
50M030050N004	M3 X .5 X 4MM Pan Slot	50M060100N016	M6 X 1.00 X 16MM Pan Slot
50M030050N005	M3 X .5 X 5MM Pan Slot	50M060100N020	M6 X 1.00 X 20MM Pan Slot
50M030050N006	M3 X .5 X 6MM Pan Slot	50M060100N022	M6 X 1.00 X 22MM Pan Slot
50M030050N008	M3 X .5 X 8MM Pan Slot	50M060100N025	M6 X 1.00 X 25MM Pan Slot
50M030050N010	M3 X .5 X 10MM Pan Slot	50M060100N030	M6 X 1.00 X 30MM Pan Slot
50M030050N012	M3 X .5 X 12MM Pan Slot	50M060100N035	M6 X 1.00 X 35MM Pan Slot
50M030050N016	M3 X .5 X 16MM Pan Slot	50M060100N040	M6 X 1.00 X 40MM Pan Slot
50M030050N020	M3 X .5 X 20MM Pan Slot	50M060100N045	M6 X 1.00 X 45MM Pan Slot
50M030050N025	M3 X .5 X 25MM Pan Slot	50M060100N050	M6 X 1.00 X 50MM Pan Slot
50M030050N030	M3 X .5 X 30MM Pan Slot	50M060100N060	M6 X 1.00 X 60MM Pan Slot
50M030050N035	M3 X .5 X 35MM Pan Slot	50M060100N070	M6 X 1.00 X 70MM Pan Slot
50M030050N042	M3 X .5 X 42MM Pan Slot	50M060100N075	M6 X 1.00 X 75MM Pan Slot
50M035060N005	M3.5 X .6 X 5MM Pan Slot	50M080125N010	M8 X 1.25 X 10MM Pan Slot
50M035060N006	M3.5 X .6 X 6MM Pan Slot	50M080125N016	M8 X 1.25 X 16MM Pan Slot
50M035060N007	M3.5 X .6 X 7MM Pan Slot	50M080125N020	M8 X 1.25 X 20MM Pan Slot
50M035060N008	M3.5 X .6 X 8MM Pan Slot	50M080125N025	M8 X 1.25 X 25MM Pan Slot
50M035060N010	M3.5 X .6 X 10MM Pan Slot	50M080125N030	M8 X 1.25 X 30MM Pan Slot
50M035060N012	M3.5 X .6 X 12MM Pan Slot	50M080125N035	M8 X 1.25 X 35MM Pan Slot
50M035060N016	M3.5 X .6 X 16MM Pan Slot	50M080125N050	M8 X 1.25 X 50MM Pan Slot
50M035060N020	M3.5 X .6 X 20MM Pan Slot	50M080125N070	M8 X 1.25 X 70MM Pan Slot
50M035060N025	M3.5 X .6 X 25MM Pan Slot	50M100150N013	M10 X 1.50 X 13MM Pan Slot
50M035060N035	M3.5 X .6 X 35MM Pan Slot	50M100150N016	M10 X 1.50 X 16MM Pan Slot
50M035060N042	M3.5 X .6 X 42MM Pan Slot	50M100150N019	M10 X 1.50 X 19MM Pan Slot
50M040070N003	M4 X .7 X 3MM Pan Slot	50M100150N020	M10 X 1.50 X 20MM Pan Slot
50M040070N006	M4 X .7 X 6MM Pan Slot	50M100150N025	M10 X 1.50 X 25MM Pan Slot
50M040070N008	M4 X .7 X 8MM Pan Slot	50M100150N030	M10 X 1.50 X 30MM Pan Slot
50M040070N010	M4 X .7 X 10MM Pan Slot	50M100150N035	M10 X 1.50 X 35MM Pan Slot
50M040070N012	M4 X .7 X 12MM Pan Slot	50M100150N050	M10 X 1.50 X 50MM Pan Slot
50M040070N016	M4 X .7 X 16MM Pan Slot	50M100150N060	M10 X 1.50 X 60MM Pan Slot
50M040070N020	M4 X .7 X 20MM Pan Slot		

PAN SLOTTED
Molded in Natural
Nylon 6/6

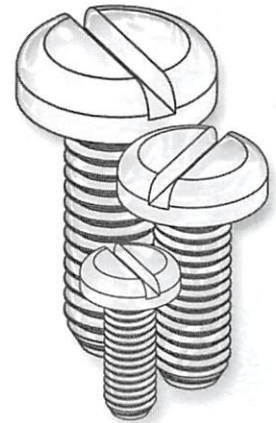

THREAD SIZE	A	H	J	T
M2	3.7 - 4.0	1.1 - 1.3	0.5 - 0.7	0.5 min.
M2.5	4.7 - 5.0	1.3 - 1.5	0.6 - 0.8	0.6 min.
M3	5.3 - 5.6	1.6 - 1.8	0.8 - 1.0	0.7 min.
M3.5	6.6 - 7.0	1.9 - 2.1	1.0 - 1.2	0.8 min.
M4	7.6 - 8.0	2.2 - 2.4	1.2 - 1.5	1.0 min.
M5	9.1 - 9.5	2.7 - 3.0	1.2 - 1.5	1.2 min.
M6	11.5 - 12.0	3.3 - 3.6	1.6 - 1.9	1.4 min.
M8	15.5 - 16.0	4.5 - 4.8	2.0 - 2.3	1.9 min.
M10	19.4 - 20.0	5.7 - 6.0	2.5 - 2.8	2.4 min.



METRIC SCREWS, BOLTS & THREADED ROD

SECTION
XII

ALL DIMENSIONS ARE IN MILLIMETERS

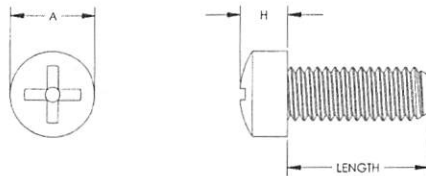

FILLISTER PHILLIPS

Molded in Natural Nylon 6/6



THREAD SIZE	A	H
M2 X 0.4	3.8	1.60
M2.5 X 0.45	5.0	2.00
M3 X 0.5	6.0	2.40
M3.5 X 0.6	7.0	2.70
M4 X 0.7	8.0	3.10
M5 X 0.8	9.45	3.80
M6 X 1.0	12.0	4.60
M8 X 1.25	16.0	6.00
M10 X 1.5	18.0	7.00

ITEM NUMBER	-----	DESCRIPTION	-----
50M020040G004	M2	X .4 X 4MM	Fill Phil
50M020040G005	M2	X .4 X 5MM	Fill Phil
50M020040G006	M2	X .4 X 6MM	Fill Phil
50M020040G008	M2	X .4 X 8MM	Fill Phil
50M020040G010	M2	X .4 X 10MM	Fill Phil
50M020040G012	M2	X .4 X 12MM	Fill Phil
50M020040G016	M2	X .4 X 16MM	Fill Phil
50M020040G020	M2	X .4 X 20MM	Fill Phil
50M020040G025	M2	X .4 X 25MM	Fill Phil
50M025045G004	M2.5	X .45 X 4MM	Fill Phil
50M025045G005	M2.5	X .45 X 5MM	Fill Phil
50M025045G006	M2.5	X .45 X 6MM	Fill Phil
50M025045G008	M2.5	X .45 X 8MM	Fill Phil
50M025045G010	M2.5	X .45 X 10MM	Fill Phil
50M025045G012	M2.5	X .45 X 12MM	Fill Phil
50M025045G016	M2.5	X .45 X 16MM	Fill Phil
50M025045G020	M2.5	X .45 X 20MM	Fill Phil
50M025045G025	M2.5	X .45 X 25MM	Fill Phil
50M030050G004	M3	X .5 X 4MM	Fill Phil
50M030050G005	M3	X .5 X 5MM	Fill Phil
50M030050G006	M3	X .5 X 6MM	Fill Phil
50M030050G008	M3	X .5 X 8MM	Fill Phil
50M030050G010	M3	X .5 X 10MM	Fill Phil
50M030050G012	M3	X .5 X 12MM	Fill Phil
50M030050G016	M3	X .5 X 16MM	Fill Phil
50M030050G020	M3	X .5 X 20MM	Fill Phil
50M030050G025	M3	X .5 X 25MM	Fill Phil
50M030050G030	M3	X .5 X 30MM	Fill Phil
50M030050G035	M3	X .5 X 35MM	Fill Phil
50M030050G042	M3	X .5 X 42MM	Fill Phil
50M035060G005	M3.5	X .6 X 5MM	Fill Phil
50M035060G006	M3.5	X .6 X 6MM	Fill Phil
50M035060G007	M3.5	X .6 X 7MM	Fill Phil
50M035060G008	M3.5	X .6 X 8MM	Fill Phil
50M035060G010	M3.5	X .6 X 10MM	Fill Phil
50M035060G012	M3.5	X .6 X 12MM	Fill Phil
50M035060G016	M3.5	X .6 X 16MM	Fill Phil
50M035060G020	M3.5	X .6 X 20MM	Fill Phil
50M035060G025	M3.5	X .6 X 25MM	Fill Phil
50M035060G035	M3.5	X .6 X 35MM	Fill Phil
50M035060G042	M3.5	X .6 X 42MM	Fill Phil
50M040070G003	M4	X .7 X 3MM	Fill Phil
50M040070G006	M4	X .7 X 6MM	Fill Phil
50M040070G008	M4	X .7 X 8MM	Fill Phil
50M040070G010	M4	X .7 X 10MM	Fill Phil
50M040070G012	M4	X .7 X 12MM	Fill Phil
50M040070G016	M4	X .7 X 16MM	Fill Phil
50M040070G020	M4	X .7 X 20MM	Fill Phil

ITEM NUMBER	-----	DESCRIPTION	-----
50M040070G025	M4	X .7 X 25MM	Fill Phil
50M040070G030	M4	X .7 X 30MM	Fill Phil
50M040070G035	M4	X .7 X 35MM	Fill Phil
50M040070G040	M4	X .7 X 40MM	Fill Phil
50M050080G006	M5	X .8 X 6MM	Fill Phil
50M050080G008	M5	X .8 X 8MM	Fill Phil
50M050080G010	M5	X .8 X 10MM	Fill Phil
50M050080G012	M5	X .8 X 12MM	Fill Phil
50M050080G015	M5	X .8 X 15MM	Fill Phil
50M050080G016	M5	X .8 X 16MM	Fill Phil
50M050080G020	M5	X .8 X 20MM	Fill Phil
50M050080G025	M5	X .8 X 25MM	Fill Phil
50M050080G030	M5	X .8 X 30MM	Fill Phil
50M050080G035	M5	X .8 X 35MM	Fill Phil
50M050080G040	M5	X .8 X 40MM	Fill Phil
50M060100G005	M6	X 1.0 X 5MM	Fill Phil
50M060100G008	M6	X 1.00 X 8MM	Fill Phil
50M060100G010	M6	X 1.00 X 10MM	Fill Phil
50M060100G012	M6	X 1.00 X 12MM	Fill Phil
50M060100G016	M6	X 1.00 X 16MM	Fill Phil
50M060100G020	M6	X 1.00 X 20MM	Fill Phil
50M060100G022	M6	X 1.00 X 22MM	Fill Phil
50M060100G025	M6	X 1.00 X 25MM	Fill Phil
50M060100G030	M6	X 1.00 X 30MM	Fill Phil
50M060100G035	M6	X 1.00 X 35MM	Fill Phil
50M060100G040	M6	X 1.00 X 40MM	Fill Phil
50M060100G045	M6	X 1.00 X 45MM	Fill Phil
50M060100G050	M6	X 1.00 X 50MM	Fill Phil
50M060100G060	M6	X 1.00 X 60MM	Fill Phil
50M060100G070	M6	X 1.00 X 70MM	Fill Phil
50M060100G075	M6	X 1.00 X 75MM	Fill Phil
50M080125G010	M8	X 1.25 X 10MM	Fill Phil
50M080125G016	M8	X 1.25 X 16MM	Fill Phil
50M080125G020	M8	X 1.25 X 20MM	Fill Phil
50M080125G025	M8	X 1.25 X 25MM	Fill Phil
50M080125G030	M8	X 1.25 X 30MM	Fill Phil
50M080125G035	M8	X 1.25 X 35MM	Fill Phil
50M080125G050	M8	X 1.25 X 50MM	Fill Phil
50M080125G070	M8	X 1.25 X 70MM	Fill Phil
50M100150G013	M10	X 1.50 X 13MM	Fill Phil
50M100150G016	M10	X 1.50 X 16MM	Fill Phil
50M100150G019	M10	X 1.50 X 19MM	Fill Phil
50M100150G020	M10	X 1.50 X 20MM	Fill Phil
50M100150G025	M10	X 1.50 X 25MM	Fill Phil
50M100150G030	M10	X 1.50 X 30MM	Fill Phil
50M100150G035	M10	X 1.50 X 35MM	Fill Phil
50M100150G050	M10	X 1.50 X 50MM	Fill Phil
50M100150G060	M10	X 1.50 X 60MM	Fill Phil



METRIC SCREWS, BOLTS & THREADED ROD

ALL DIMENSIONS ARE IN MILLIMETERS

SECTION
XII

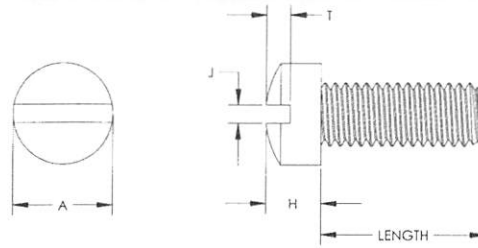

ITEM NUMBER	DESCRIPTION
50M020040F004	M2 X .4 X 4MM Fill Slot
50M020040F005	M2 X .4 X 5MM Fill Slot
50M020040F006	M2 X .4 X 6MM Fill Slot
50M020040F008	M2 X .4 X 8MM Fill Slot
50M020040F010	M2 X .4 X 10MM Fill Slot
50M020040F012	M2 X .4 X 12MM Fill Slot
50M020040F016	M2 X .4 X 16MM Fill Slot
50M020040F020	M2 X .4 X 20MM Fill Slot
50M020040F025	M2 X .4 X 25MM Fill Slot
50M025045F004	M2.5 X .45 X 4MM Fill Slot
50M025045F005	M2.5 X .45 X 5MM Fill Slot
50M025045F006	M2.5 X .45 X 6MM Fill Slot
50M025045F008	M2.5 X .45 X 8MM Fill Slot
50M025045F010	M2.5 X .45 X 10MM Fill Slot
50M025045F012	M2.5 X .45 X 12MM Fill Slot
50M025045F016	M2.5 X .45 X 16MM Fill Slot
50M025045F020	M2.5 X .45 X 20MM Fill Slot
50M025045F025	M2.5 X .45 X 25MM Fill Slot
50M030050F004	M3 X .5 X 4MM Fill Slot
50M030050F005	M3 X .5 X 5MM Fill Slot
50M030050F006	M3 X .5 X 6MM Fill Slot
50M030050F008	M3 X .5 X 8MM Fill Slot
50M030050F010	M3 X .5 X 10MM Fill Slot
50M030050F012	M3 X .5 X 12MM Fill Slot
50M030050F016	M3 X .5 X 16MM Fill Slot
50M030050F020	M3 X .5 X 20MM Fill Slot
50M030050F025	M3 X .5 X 25MM Fill Slot
50M030050F030	M3 X .5 X 30MM Fill Slot
50M030050F035	M3 X .5 X 35MM Fill Slot
50M030050F042	M3 X .5 X 42MM Fill Slot
50M035060F005	M3.5 X .6 X 5MM Fill Slot
50M035060F006	M3.5 X .6 X 6MM Fill Slot
50M035060F007	M3.5 X .6 X 7MM Fill Slot
50M035060F008	M3.5 X .6 X 8MM Fill Slot
50M035060F010	M3.5 X .6 X 10MM Fill Slot
50M035060F012	M3.5 X .6 X 12MM Fill Slot
50M035060F016	M3.5 X .6 X 16MM Fill Slot
50M035060F020	M3.5 X .6 X 20MM Fill Slot
50M035060F025	M3.5 X .6 X 25MM Fill Slot
50M035060F035	M3.5 X .6 X 35MM Fill Slot
50M035060F042	M3.5 X .6 X 42MM Fill Slot
50M040070F003	M4 X .7 X 3MM Fill Slot
50M040070F006	M4 X .7 X 6MM Fill Slot
50M040070F008	M4 X .7 X 8MM Fill Slot
50M040070F010	M4 X .7 X 10MM Fill Slot
50M040070F012	M4 X .7 X 12MM Fill Slot
50M040070F016	M4 X .7 X 16MM Fill Slot
50M040070F020	M4 X .7 X 20MM Fill Slot

ITEM NUMBER	DESCRIPTION
50M040070F025	M4 X .7 X 25MM Fill Slot
50M040070F030	M4 X .7 X 30MM Fill Slot
50M040070F035	M4 X .7 X 35MM Fill Slot
50M040070F040	M4 X .7 X 40MM Fill Slot
50M050080F006	M5 X .8 X 6MM Fill Slot
50M050080F008	M5 X .8 X 8MM Fill Slot
50M050080F010	M5 X .8 X 10MM Fill Slot
50M050080F012	M5 X .8 X 12MM Fill Slot
50M050080F015	M5 X .8 X 15MM Fill Slot
50M050080F016	M5 X .8 X 16MM Fill Slot
50M050080F020	M5 X .8 X 20MM Fill Slot
50M050080F025	M5 X .8 X 25MM Fill Slot
50M050080F030	M5 X .8 X 30MM Fill Slot
50M050080F035	M5 X .8 X 35MM Fill Slot
50M050080F040	M5 X .8 X 40MM Fill Slot
50M060100F005	M6 X 1.00 X 5MM Fill Slot
50M060100F008	M6 X 1.00 X 8MM Fill Slot
50M060100F010	M6 X 1.00 X 10MM Fill Slot
50M060100F012	M6 X 1.00 X 12MM Fill Slot
50M060100F016	M6 X 1.00 X 16MM Fill Slot
50M060100F020	M6 X 1.00 X 20MM Fill Slot
50M060100F022	M6 X 1.00 X 22MM Fill Slot
50M060100F025	M6 X 1.00 X 25MM Fill Slot
50M060100F030	M6 X 1.00 X 30MM Fill Slot
50M060100F035	M6 X 1.00 X 35MM Fill Slot
50M060100F040	M6 X 1.00 X 40MM Fill Slot
50M060100F045	M6 X 1.00 X 45MM Fill Slot
50M060100F050	M6 X 1.00 X 50MM Fill Slot
50M060100F060	M6 X 1.00 X 60MM Fill Slot
50M060100F070	M6 X 1.00 X 70MM Fill Slot
50M060100F075	M6 X 1.00 X 75MM Fill Slot
50M080125F010	M8 X 1.25 X 10MM Fill Slot
50M080125F016	M8 X 1.25 X 16MM Fill Slot
50M080125F020	M8 X 1.25 X 20MM Fill Slot
50M080125F025	M8 X 1.25 X 25MM Fill Slot
50M080125F030	M8 X 1.25 X 30MM Fill Slot
50M080125F035	M8 X 1.25 X 35MM Fill Slot
50M080125F050	M8 X 1.25 X 50MM Fill Slot
50M080125F070	M8 X 1.25 X 70MM Fill Slot
50M100150F013	M10 X 1.50 X 13MM Fill Slot
50M100150F016	M10 X 1.50 X 16MM Fill Slot
50M100150F019	M10 X 1.50 X 19MM Fill Slot
50M100150F020	M10 X 1.50 X 20MM Fill Slot
50M100150F025	M10 X 1.50 X 25MM Fill Slot
50M100150F030	M10 X 1.50 X 30MM Fill Slot
50M100150F035	M10 X 1.50 X 35MM Fill Slot
50M100150F050	M10 X 1.50 X 50MM Fill Slot
50M100150F060	M10 X 1.50 X 60MM Fill Slot

FILLISTER SLOTTED
Molded in Natural Nylon 6/6

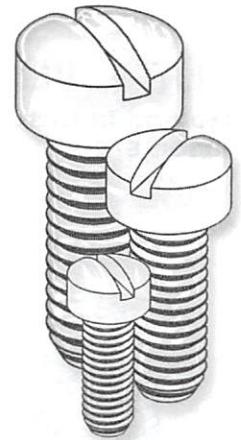

THREAD SIZE	A	H	J	T
M2 X 0.4	3.8	1.60	0.60	0.90
M2.5 X 0.45	5.0	2.00	0.70	1.10
M3 X 0.5	6.0	2.40	1.00	1.30
M3.5 X 0.6	7.0	2.70	1.10	1.40
M4 X 0.7	8.0	3.10	1.20	1.60
M5 X 0.8	9.4	3.80	1.50	2.00
M6 X 1.0	12.0	4.60	1.90	2.30
M8 X 1.25	16.0	6.00	2.30	2.80
M10 X 1.5	20.0	7.50	2.80	3.20



METRIC SCREWS, BOLTS & THREADED ROD

SECTION
XII

ALL DIMENSIONS ARE IN MILLIMETERS

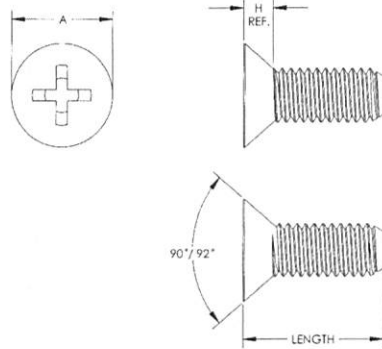

THREAD SIZE	A	* H
M2 X 0.4	3.5 - 4.4	1.2 max ref.
M2.5 X 0.45	4.4 - 5.5	1.5 max ref.
M3 X 0.5	5.2 - 6.3	1.7 max ref.
M3.5 X 0.6	6.9 - 8.2	2.3 max ref.
M4 X 0.7	8.0 - 9.4	2.7 max ref.
M5 X 0.8	8.9 - 10.4	2.7 max ref.
M6 X 1	10.9 - 12.6	3.3 max ref.
M8 X 1.25	15.4 - 17.3	4.6 max ref.
M10 X 1.5	17.8 - 20.0	5.0 max ref.

* H Dimension is a reference dimension only.

FLAT PHILLIPS

Molded in **Natural Nylon 6/6**



ITEM NUMBER	DESCRIPTION
50M025045I004	M2.5 X .45 X 4MM Flat Phil
50M025045I005	M2.5 X .45 X 5MM Flat Phil
50M025045I006	M2.5 X .45 X 6MM Flat Phil
50M025045I008	M2.5 X .45 X 8MM Flat Phil
50M025045I010	M2.5 X .45 X 10MM Flat Phil
50M025045I012	M2.5 X .45 X 12MM Flat Phil
50M025045I016	M2.5 X .45 X 16MM Flat Phil
50M025045I020	M2.5 X .45 X 20MM Flat Phil
50M025045I025	M2.5 X .45 X 25MM Flat Phil
50M030050I005	M3 X .5 X 5MM Flat Phil
50M030050I006	M3 X .5 X 6MM Flat Phil
50M030050I008	M3 X .5 X 8MM Flat Phil
50M030050I010	M3 X .5 X 10MM Flat Phil
50M030050I012	M3 X .5 X 12MM Flat Phil
50M030050I016	M3 X .5 X 16MM Flat Phil
50M030050I020	M3 X .5 X 20MM Flat Phil
50M030050I025	M3 X .5 X 25MM Flat Phil
50M035060I005	M3.5 X .6 X 5MM Flat Phil
50M035060I006	M3.5 X .6 X 6MM Flat Phil
50M035060I008	M3.5 X .6 X 8MM Flat Phil
50M035060I010	M3.5 X .6 X 10MM Flat Phil
50M035060I012	M3.5 X .6 X 12MM Flat Phil
50M035060I016	M3.5 X .6 X 16MM Flat Phil
50M035060I020	M3.5 X .6 X 20MM Flat Phil
50M035060I025	M3.5 X .6 X 25MM Flat Phil
50M035060I035	M3.5 X .6 X 35MM Flat Phil
50M040070I006	M4 X .7 X 6MM Flat Phil
50M040070I008	M4 X .7 X 8MM Flat Phil
50M040070I010	M4 X .7 X 10MM Flat Phil
50M040070I012	M4 X .7 X 12MM Flat Phil

ITEM NUMBER	DESCRIPTION
50M040070I016	M4 X .7 X 16MM Flat Phil
50M040070I020	M4 X .7 X 20MM Flat Phil
50M040070I025	M4 X .7 X 25MM Flat Phil
50M050080I006	M5 X .8 X 6MM Flat Phil
50M050080I008	M5 X .8 X 8MM Flat Phil
50M050080I010	M5 X .8 X 10MM Flat Phil
50M050080I012	M5 X .8 X 12MM Flat Phil
50M050080I016	M5 X .8 X 16MM Flat Phil
50M050080I020	M5 X .8 X 20MM Flat Phil
50M050080I025	M5 X .8 X 25MM Flat Phil
50M050080I030	M5 X .8 X 30MM Flat Phil
50M050080I040	M5 X .8 X 40MM Flat Phil
50M060100I008	M6 X 1.00 X 8MM Flat Phil
50M060100I010	M6 X 1.00 X 10MM Flat Phil
50M060100I012	M6 X 1.00 X 12MM Flat Phil
50M060100I016	M6 X 1.00 X 16MM Flat Phil
50M060100I020	M6 X 1.00 X 20MM Flat Phil
50M060100I025	M6 X 1.00 X 25MM Flat Phil
50M060100I035	M6 X 1.00 X 35MM Flat Phil
50M060100I045	M6 X 1.00 X 45MM Flat Phil
50M080125I010	M8 X 1.25 X 10MM Flat Phil
50M080125I016	M8 X 1.25 X 16MM Flat Phil
50M080125I020	M8 X 1.25 X 20MM Flat Phil
50M080125I025	M8 X 1.25 X 25MM Flat Phil
50M080125I030	M8 X 1.25 X 30MM Flat Phil
50M080125I050	M8 X 1.25 X 50MM Flat Phil
50M100150I020	M10 X 1.50 X 20MM Flat Phil
50M100150I025	M10 X 1.50 X 25MM Flat Phil
50M100150I035	M10 X 1.50 X 35MM Flat Phil

Metric Button Head Socket Cap Screw

Molded in **Natural Nylon 6/6**



ITEM NUMBER
50M080125BH015

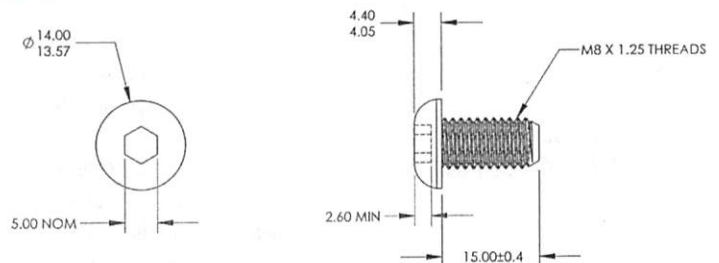

METRIC SCREWS, BOLTS & THREADED ROD

ALL DIMENSIONS ARE IN MILLIMETERS

SECTION
XII

THREAD SIZE	A	H	J	T
M2 X 0.4	3.5 - 4.4	1.2 max ref.	0.5 - 0.7	0.4 - 0.6
M2.5 X 0.45	4.4 - 5.5	1.5 max ref.	0.6 - 0.8	0.5 - 0.7
M3 X 0.5	5.2 - 6.3	1.7 max ref.	0.8 - 1.0	0.6 - 0.9
M3.5 X 0.6	6.9 - 8.2	2.3 max ref.	1.0 - 1.2	0.9 - 1.2
M4 X 0.7	8.0 - 9.4	2.7 max ref.	1.2 - 1.5	1.0 - 1.3
M5 X 0.8	8.9 - 10.4	2.7 max ref.	1.2 - 1.5	1.1 - 1.4
M6 X 1	10.9 - 12.6	3.3 max ref.	1.6 - 1.9	1.2 - 1.6
M8 X 1.25	15.4 - 17.3	4.6 max ref.	2.0 - 2.3	1.8 - 2.3
M10 X 1.5	17.8 - 20.0	5.0 max ref.	2.5 - 2.8	2.0 - 2.6

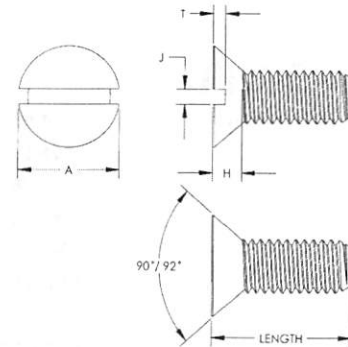

ITEM NUMBER	DESCRIPTION
50M020040H004	M2 X .4 X 4MM Flat Slot
50M020040H005	M2 X .4 X 5MM Flat Slot
50M020040H006	M2 X .4 X 6MM Flat Slot
50M020040H008	M2 X .4 X 8MM Flat Slot
50M020040H010	M2 X .4 X 10MM Flat Slot
50M020040H011	M2 X .4 X 11MM Flat Slot
50M020040H012	M2 X .4 X 12MM Flat Slot
50M020040H016	M2 X .4 X 16MM Flat Slot
50M020040H025	M2 X .4 X 25MM Flat Slot
50M025045H004	M2.5 X .45 X 4MM Flat Slot
50M025045H005	M2.5 X .45 X 5MM Flat Slot
50M025045H006	M2.5 X .45 X 6MM Flat Slot
50M025045H008	M2.5 X .45 X 8MM Flat Slot
50M025045H010	M2.5 X .45 X 10MM Flat Slot
50M025045H012	M2.5 X .45 X 12MM Flat Slot
50M025045H016	M2.5 X .45 X 16MM Flat Slot
50M025045H020	M2.5 X .45 X 20MM Flat Slot
50M025045H025	M2.5 X .45 X 25MM Flat Slot
50M030050H005	M3 X .5 X 5MM Flat Slot
50M030050H006	M3 X .5 X 6MM Flat Slot
50M030050H008	M3 X .5 X 8MM Flat Slot
50M030050H010	M3 X .5 X 10MM Flat Slot
50M030050H012	M3 X .5 X 12MM Flat Slot
50M030050H015	M3 X .5 X 15MM Flat Slot
50M030050H016	M3 X .5 X 16MM Flat Slot
50M030050H020	M3 X .5 X 20MM Flat Slot
50M030050H025	M3 X .5 X 25MM Flat Slot
50M030050H030	M3 X .5 X 30MM Flat Slot
50M030050H042	M3 X .5 X 42MM Flat Slot
50M035060H005	M3.5 X .6 X 5MM Flat Slot
50M035060H006	M3.5 X .6 X 6MM Flat Slot
50M035060H008	M3.5 X .6 X 8MM Flat Slot
50M035060H010	M3.5 X .6 X 10MM Flat Slot
50M035060H016	M3.5 X .6 X 16MM Flat Slot
50M035060H025	M3.5 X .6 X 25MM Flat Slot
50M035060H035	M3.5 X .6 X 35MM Flat Slot
50M040070H006	M4 X .7 X 6MM Flat Slot
50M040070H008	M4 X .7 X 8MM Flat Slot

ITEM NUMBER	DESCRIPTION
50M040070H010	M4 X .7 X 10MM Flat Slot
50M040070H012	M4 X .7 X 12MM Flat Slot
50M040070H015	M4 X .7 X 15MM Flat Slot
50M040070H016	M4 X .7 X 16MM Flat Slot
50M040070H020	M4 X .7 X 20MM Flat Slot
50M040070H025	M4 X .7 X 25MM Flat Slot
50M040070H030	M4 X .7 X 30MM Flat Slot
50M040070H035	M4 X .7 X 35MM Flat Slot
50M050080H006	M5 X .8 X 6MM Flat Slot
50M050080H008	M5 X .8 X 8MM Flat Slot
50M050080H010	M5 X .8 X 10MM Flat Slot
50M050080H012	M5 X .8 X 12MM Flat Slot
50M050080H015	M5 X .8 X 15MM Flat Slot
50M050080H016	M5 X .8 X 16MM Flat Slot
50M050080H020	M5 X .8 X 20MM Flat Slot
50M050080H025	M5 X .8 X 25MM Flat Slot
50M050080H030	M5 X .8 X 30MM Flat Slot
50M050080H040	M5 X .8 X 40MM Flat Slot
50M060100H008	M6 X 1.00 X 8MM Flat Slot
50M060100H010	M6 X 1.00 X 10MM Flat Slot
50M060100H012	M6 X 1.00 X 12MM Flat Slot
50M060100H016	M6 X 1.00 X 16MM Flat Slot
50M060100H020	M6 X 1.00 X 20MM Flat Slot
50M060100H025	M6 X 1.00 X 25MM Flat Slot
50M060100H035	M6 X 1.00 X 35MM Flat Slot
50M060100H040	M6 X 1.00 X 40MM Flat Slot
50M060100H045	M6 X 1.00 X 45MM Flat Slot
50M060100H050	M6 X 1.00 X 50MM Flat Slot
50M080125H016	M8 X 1.25 X 16MM Flat Slot
50M080125H020	M8 X 1.25 X 20MM Flat Slot
50M080125H025	M8 X 1.25 X 25MM Flat Slot
50M080125H030	M8 X 1.25 X 30MM Flat Slot
50M080125H050	M8 X 1.25 X 50MM Flat Slot
50M100150H020	M10 X 1.50 X 20MM Flat Slot
50M100150H025	M10 X 1.50 X 25MM Flat Slot
50M100150H030	M10 X 1.50 X 30MM Flat Slot
50M100150H035	M10 X 1.50 X 35MM Flat Slot
50M100150H060	M10 X 1.50 X 60MM Flat Slot

FLAT SLOTTED
Molded in Natural Nylon 6/6

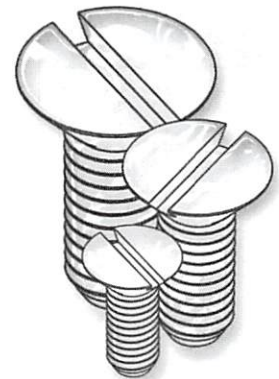

METRIC SCREWS, BOLTS & THREADED ROD

SECTION
XII

ALL DIMENSIONS ARE IN MILLIMETERS

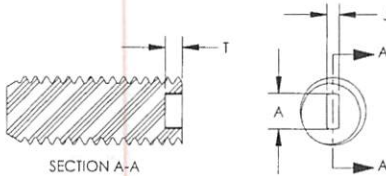

APE Above Board Electronics, Inc. www.aboveboardelectronics.com
1-800-453-1692

**New
SIZES**

GRUB SLOTTED

Molded in **Natural Nylon 6/6**



THREAD SIZE	A	J	T
M4 X 0.7	2.0	.64	.76
M5 X 0.8	3.3	.89	1.3
M6 X 1.0	4.1	1.0	1.5
M8 X 1.25	5.1	1.6	2.2
M10 X 1.5	6.6	1.5	2.5

ITEM NUMBER	DESCRIPTION
50M040070R003	M4 X .7 X 3MM Grub Slot
50M040070R004	M4 X .7 X 4MM Grub Slot
50M040070R006	M4 X .7 X 6MM Grub Slot
50M040070R008	M4 X .7 X 8MM Grub Slot
50M040070R010	M4 X .7 X 10MM Grub Slot
50M040070R012	M4 X .7 X 12MM Grub Slot
50M040070R016	M4 X .7 X 16MM Grub Slot
50M040070R020	M4 X .7 X 20MM Grub Slot
50M040070R025	M4 X .7 X 25MM Grub Slot
50M040070R030	M4 X .7 X 30MM Grub Slot
50M040070R035	M4 X .7 X 35MM Grub Slot
50M040070R040	M4 X .7 X 40MM Grub Slot
50M050080R006	M5 X .8 X 6MM Grub Slot
50M050080R008	M5 X .8 X 8MM Grub Slot
50M050080R010	M5 X .8 X 10MM Grub Slot
50M050080R012	M5 X .8 X 12MM Grub Slot
50M050080R013	M5 X .8 X 13MM Grub Slot
50M050080R016	M5 X .8 X 16MM Grub Slot
50M050080R020	M5 X .8 X 20MM Grub Slot
50M050080R025	M5 X .8 X 25MM Grub Slot
50M050080R030	M5 X .8 X 30MM Grub Slot
50M050080R040	M5 X .8 X 40MM Grub Slot
50M060100R005	M6 X 1.0 X 5MM Grub Slot
50M060100R008	M6 X 1.0 X 8MM Grub Slot
50M060100R010	M6 X 1.0 X 10MM Grub Slot
50M060100R012	M6 X 1.0 X 12MM Grub Slot
50M060100R016	M6 X 1.0 X 16MM Grub Slot

ITEM NUMBER	DESCRIPTION
50M060100R020	M6 X 1.0 X 20MM Grub Slot
50M060100R022	M6 X 1.0 X 22MM Grub Slot
50M060100R025	M6 X 1.0 X 25MM Grub Slot
50M060100R030	M6 X 1.0 X 30MM Grub Slot
50M060100R035	M6 X 1.0 X 35MM Grub Slot
50M060100R045	M6 X 1.0 X 45MM Grub Slot
50M060100R050	M6 X 1.0 X 50MM Grub Slot
50M060100R060	M6 X 1.0 X 60MM Grub Slot
50M060100R070	M6 X 1.0 X 70MM Grub Slot
50M060100R075	M6 X 1.0 X 75MM Grub Slot
50M080125R008	M8 X 1.25 X 8MM Grub Slot
50M080125R010	M8 X 1.25 X 10MM Grub Slot
50M080125R016	M8 X 1.25 X 16MM Grub Slot
50M080125R020	M8 X 1.25 X 20MM Grub Slot
50M080125R025	M8 X 1.25 X 25MM Grub Slot
50M080125R030	M8 X 1.25 X 30MM Grub Slot
50M080125R035	M8 X 1.25 X 35MM Grub Slot
50M080125R050	M8 X 1.25 X 50MM Grub Slot
50M100150R010	M10 X 1.5 X 10MM Grub Slot
50M100150R013	M10 X 1.5 X 13MM Grub Slot
50M100150R016	M10 X 1.5 X 16MM Grub Slot
50M100150R019	M10 X 1.5 X 19MM Grub Slot
50M100150R020	M10 X 1.5 X 20MM Grub Slot
50M100150R025	M10 X 1.5 X 25MM Grub Slot
50M100150R030	M10 X 1.5 X 30MM Grub Slot
50M100150R035	M10 X 1.5 X 35MM Grub Slot
50M100150R050	M10 X 1.5 X 50MM Grub Slot
50M100150R060	M10 X 1.5 X 60MM Grub Slot

HEX SOCKET HEAD CAP SCREW

Molded in **Natural Nylon 6/6**

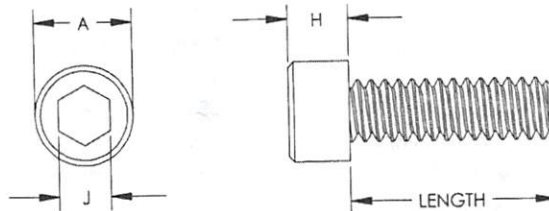
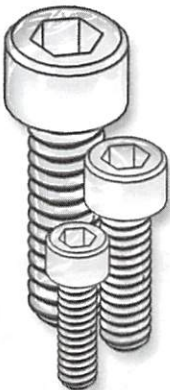

THREAD SIZE	A	H	J	HEX DEPTH
M 10	15.67 - 16.00	9.81 - 10.00	8.0 nom.	5.00 min.

ITEM NUMBER	DESCRIPTION
50M100150S013	M10 X 1.5 X 13MM Hex Soc
50M100150S016	M10 X 1.5 X 16MM Hex Soc
50M100150S019	M10 X 1.5 X 19MM Hex Soc
50M100150S020	M10 X 1.5 X 20MM Hex Soc
50M100150S025	M10 X 1.5 X 25MM Hex Soc
50M100150S030	M10 X 1.5 X 30MM Hex Soc
50M100150S035	M10 X 1.5 X 35MM Hex Soc
50M100150S050	M10 X 1.5 X 50MM Hex Soc
50M100150S060	M10 X 1.5 X 60MM Hex Soc

METRIC SCREWS, BOLTS & THREADED ROD

ALL DIMENSIONS ARE IN MILLIMETERS

SECTION
XII

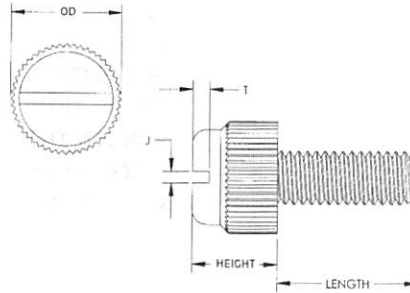
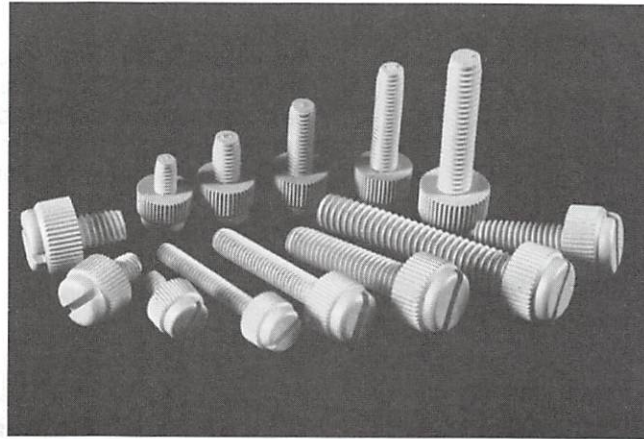
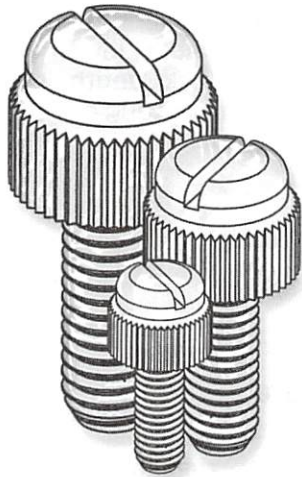

THREAD SIZE	HT.	OD	J	T
M3 X .5	5.48	8.05	.94	1.01
M3.5 X .6	6.1	8.5	.88	1.2
M4 X .7	7.1	9.70	.90	1.15
M5 X .8	7.75	10.04	1.02	1.64
M6 X 1.0	7.75	12.21	1.14	1.95

ECONOMY GRADE THUMB SCREW

Molded in Natural Nylon 6/6

ITEM NUMBER	----- DESCRIPTION -----
50M030050T004	M3 X .5 X 4MM Thumb Screw
50M030050T005	M3 X .5 X 5MM Thumb Screw
50M030050T006	M3 X .5 X 6MM Thumb Screw
50M030050T008	M3 X .5 X 8MM Thumb Screw
50M030050T010	M3 X .5 X 10MM Thumb Screw
50M030050T012	M3 X .5 X 12MM Thumb Screw
50M030050T016	M3 X .5 X 16MM Thumb Screw
50M030050T020	M3 X .5 X 20MM Thumb Screw
50M030050T025	M3 X .5 X 25MM Thumb Screw
50M030050T030	M3 X .5 X 30MM Thumb Screw
50M030050T035	M3 X .5 X 35MM Thumb Screw
50M030050T042	M3 X .5 X 42MM Thumb Screw
50M035060T005	M3.5 X .6 X 5MM Thumb Screw
50M035060T006	M3.5 X .6 X 6MM Thumb Screw
50M035060T008	M3.5 X .6 X 8MM Thumb Screw
50M035060T010	M3.5 X .6 X 10MM Thumb Screw
50M035060T012	M3.5 X .6 X 12MM Thumb Screw
50M035060T016	M3.5 X .6 X 16MM Thumb Screw
50M035060T020	M3.5 X .6 X 20MM Thumb Screw
50M035060T025	M3.5 X .6 X 25MM Thumb Screw
50M035060T035	M3.5 X .6 X 35MM Thumb Screw
50M035060T042	M3.5 X .6 X 42MM Thumb Screw
50M040070T003	M4 X .7 X 3MM Thumb Screw
50M040070T006	M4 X .7 X 6MM Thumb Screw
50M040070T008	M4 X .7 X 8MM Thumb Screw
50M040070T010	M4 X .7 X 10MM Thumb Screw
50M040070T012	M4 X .7 X 12MM Thumb Screw
50M040070T016	M4 X .7 X 16MM Thumb Screw

ITEM NUMBER	----- DESCRIPTION -----
50M040070T020	M4 X .7 X 20MM Thumb Screw
50M040070T025	M4 X .7 X 25MM Thumb Screw
50M040070T030	M4 X .7 X 30MM Thumb Screw
50M040070T035	M4 X .7 X 35MM Thumb Screw
50M040070T040	M4 X .7 X 40MM Thumb Screw
50M050080T006	M5 X .8 X 6MM Thumb Screw
50M050080T008	M5 X .8 X 8MM Thumb Screw
50M050080T010	M5 X .8 X 10MM Thumb Screw
50M050080T012	M5 X .8 X 12MM Thumb Screw
50M050080T016	M5 X .8 X 16MM Thumb Screw
50M050080T020	M5 X .8 X 20MM Thumb Screw
50M050080T025	M5 X .8 X 25MM Thumb Screw
50M050080T030	M5 X .8 X 30MM Thumb Screw
50M050080T040	M5 X .8 X 40MM Thumb Screw
50M060100T005	M6 X 1.00 X 5MM Thumb Screw
50M060100T008	M6 X 1.00 X 8MM Thumb Screw
50M060100T010	M6 X 1.00 X 10MM Thumb Screw
50M060100T012	M6 X 1.00 X 12MM Thumb Screw
50M060100T016	M6 X 1.00 X 16MM Thumb Screw
50M060100T020	M6 X 1.00 X 20MM Thumb Screw
50M060100T022	M6 X 1.00 X 22MM Thumb Screw
50M060100T025	M6 X 1.00 X 25MM Thumb Screw
50M060100T035	M6 X 1.00 X 35MM Thumb Screw
50M060100T040	M6 X 1.00 X 40MM Thumb Screw
50M060100T045	M6 X 1.00 X 45MM Thumb Screw
50M060100T050	M6 X 1.00 X 50MM Thumb Screw
50M060100T060	M6 X 1.00 X 60MM Thumb Screw
50M060100T070	M6 X 1.00 X 70MM Thumb Screw
50M060100T075	M6 X 1.00 X 75MM Thumb Screw

METRIC SCREWS, BOLTS & THREADED ROD

SECTION XII

ALL DIMENSIONS ARE IN MILLIMETERS

This versatile threaded rod stock is easily cut to size, resistant to most chemicals, electrically insulating, non-magnetic, light-weight, low thermal conductivity, vibration and abrasion resistant. Stock length is 1 meter. We can furnish cut to your length with a nominal cutting charge. Other plastic materials can be furnished on special order.



THREADED ROD

Molded in **Natural Nylon 6/6**

ITEM NUMBER	SCREW SIZE	THREAD
38M030050TR	M3	.5
38M040070TR	M4	.7
38M050080TR	M5	.8
38M060100TR	M6	1.0
38M080125TR	M8	1.25

METRIC NUTS

SECTION XIII

ALL DIMENSIONS ARE IN MILLIMETERS

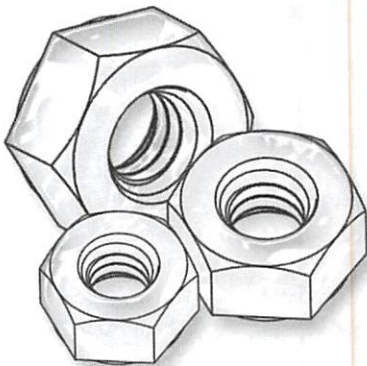
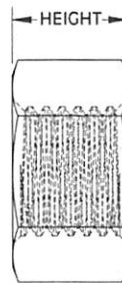
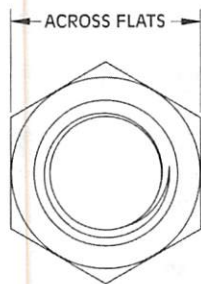

HEX NUTS - DIN 34814

Molded in **Natural Nylon 6/6**

ITEM NUMBER	SCREW SIZE		ACROSS FLATS		HEIGHT	
	SIZE	THREAD	MAX.	MIN.	MAX.	MIN.
04M030050HNDIN34814	M3	M3 X 0.5	5.5	5.32	2.4	2.15
04M040070HNDIN34814	M4	M4 X 0.7	7.0	6.78	3.2	2.9
04M050080HNDIN34814	M5	M5 X 0.8	8.0	7.78	4.7	4.4
04M060100HNDIN34814	M6	M6 X 1.0	10	9.78	5.2	4.9
04M080125HNDIN34814	M8	M8 X1.25	13	12.73	6.8	6.44
04M100150HNDIN34814	M10	M10X1.50	16	15.73	8.4	8.04
04M120175HNDIN34814	M12	M12X1.75	18	17.73	10.8	10.37
04M160200HNDIN34814	M16	M16X2.00	24	23.67	14.8	14.1

METRIC NUTS

ALL DIMENSIONS ARE IN MILLIMETERS

SECTION
XIII

HEX NUTS

Molded in Natural Nylon 6/6

ITEM NUMBER	SCREW SIZE	THREAD	ACROSS FLATS	HEIGHT
04M020040HN	M2	0.4	3.9	1.2
04M025045HN	M2.5	0.45	4.9	1.8
04M030050HN	M3	0.5	5.4	2.2
04M035060HN	M3.5	0.6	6.9	2.7
04M040070HN	M4	0.7	6.9	3.0
04M050080HN	M5	0.8	7.9	4.3
04M060100HN	M6	1.0	10.0	5.4
04M080125HN	M8	1.25	12.9	6.4
04M100150HN	M10	1.50	14.8	9.8
04M120175HN	M12	1.75	17.74	10.54

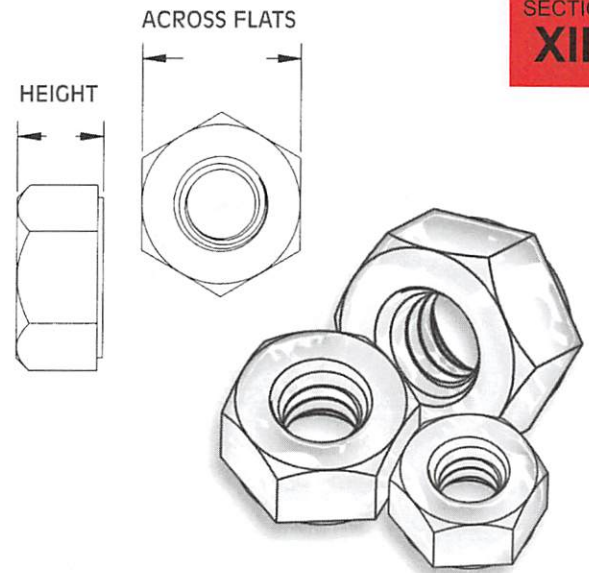

DESIGNED FOR STEEL SCREWS

LOCK NUTS

Molded in Natural Nylon 6/6

ITEM NUMBER	SCREW SIZE	THREAD	ACROSS FLATS	HEIGHT
07M060100LN	M6	1.0	10.9	6.7

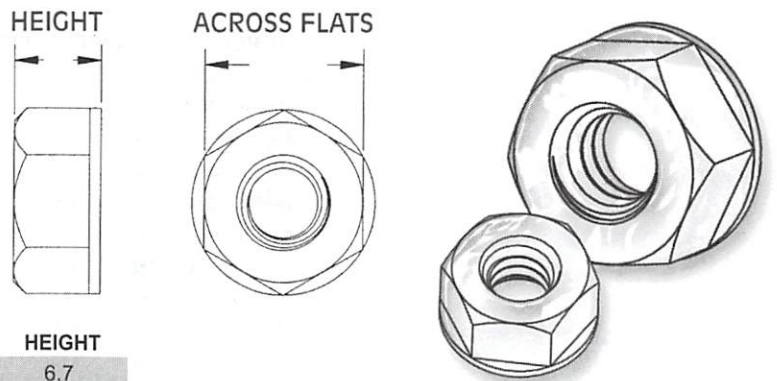

CAP NUTS

Molded in Natural Nylon 6/6

ITEM NUMBER	SCREW SIZE	THREAD	ACROSS FLATS	HEIGHT
05M040070CN	M4	0.7	7.0	8.0
05M050080CN	M5	0.8	8.0	10.0
05M060100CN	M6	1.0	10.0	12.0
05M080125CN	M8	1.25	13.0	15.0
05M100150CN	M10	1.5	17.0	18.0
05M120175CN	M12	1.75	18.9	20.5
05M160200CN	M16	2.0	23.7	24.8
05M200250CN	M20	2.5	26.7	29.1

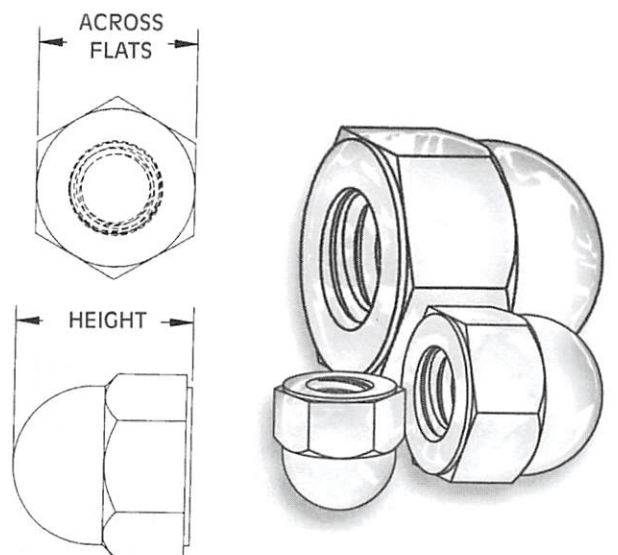

LOCKING CAP NUTS

Molded in Natural Nylon 6/6

ITEM NUMBER	SCREW SIZE	THREAD	ACROSS FLATS	HEIGHT
05M040070LCN	M4	0.7	7.0	8.0
05M050080LCN	M5	0.8	8.0	10.0
05M060100LCN	M6	1.0	10.0	12.0

METRIC NUTS

SECTION
XIII

ALL DIMENSIONS ARE IN MILLIMETERS

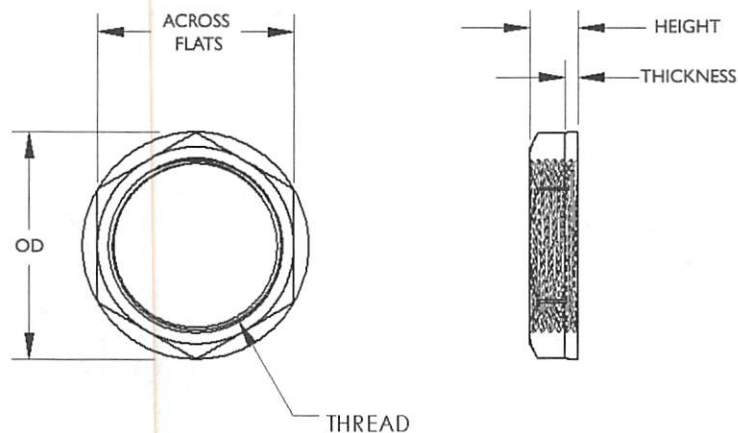

HEX FLANGE NUTS

Molded in Natural Nylon 6/6

ITEM NUMBER	SCREW SIZE	THREAD	OD	ACROSS FLATS	HEIGHT	THICKNESS
04M030050WFHN	M3	.50	6.60	5.50	3.10	0.41
04M040070WFHN	M4	.70	8.80	7.00	3.40	0.76
04M050080WFHN	M5	.80	9.80	7.90	5.20	0.94
04M060100WFHN	M6	1.00	13.00	10.00	6.00	1.02
04M080125WFHN	M8	1.25	17.00	13.00	8.00	1.52
04M100150WFHN	M10	1.50	22.00	16.00	10.00	1.91
04M120175WFHN	M12	1.75	27.00	19.00	14.50	3.05
04M160150WFHN	M16	1.50	22.00	18.92	6.70	2.00
04M160200WFHN	M16	2.00	39.00	24.00	19.50	3.18
04M200150WFHN	M20	1.50	27.00	22.86	8.00	2.38
04M250150WFHN	M25	1.50	32.00	27.94	9.00	2.50
04M320150WFHN	M32	1.50	42.00	36.45	9.02	2.54

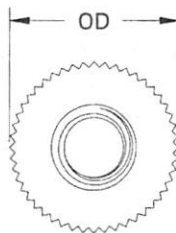

THUMB NUTS

Molded in Natural Nylon 6/6

ITEM NUMBER	SCREW SIZE	THREAD	OD	HEIGHT
08M040070TN	M4	0.7	10.8	7.8

METRIC NUTS

ALL DIMENSIONS ARE IN MILLIMETERS

SECTION
XIII



www.aboveboardelectronics.com
1-800-453-1692

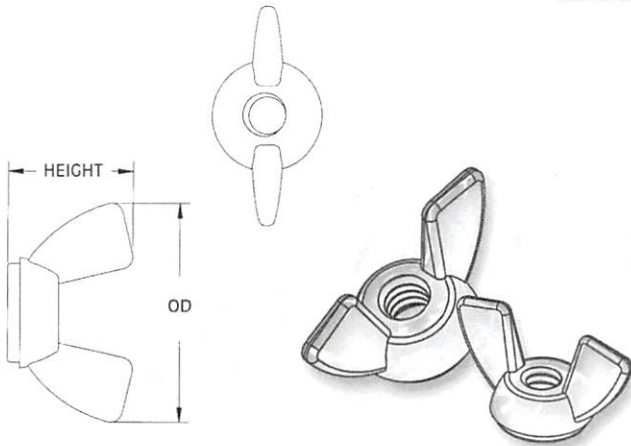

WING NUTS

Molded in Natural Nylon 6/6

ITEM NUMBER	SCREW SIZE	THREAD	OD	HEIGHT
06M040070WN	M4	0.7	22.8	12.2
06M050080WN	M5	0.8	22.8	12.2
06M060100WN	M6	1.0	27.7	16.0
06M080125WN	M8	1.25	34.8	18.3
06M100150WN	M10	1.5	34.8	18.3
06M120175WN	M12	1.7	44.7	22.7

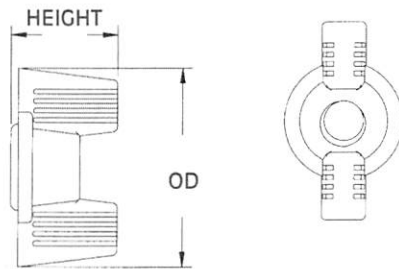

DECO WING NUTS

Molded in Natural Nylon 6/6

ITEM NUMBER	SCREW SIZE	THREAD	OD	HEIGHT
06M040070DWN	M4	0.7	16.0	8.0
06M050080DWN	M5	0.8	22.2	11.1
06M060100DWN	M6	1.0	29.7	13.4

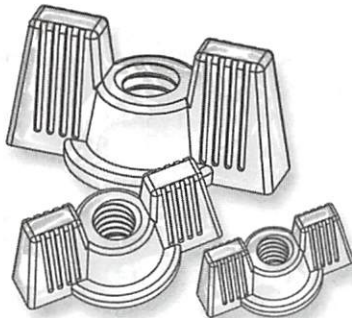

DECO LOCKING WING NUTS

Molded in Natural Nylon 6/6

ITEM NUMBER	SCREW SIZE	THREAD	OD	HEIGHT
06M040070DLWN	M4	0.7	16.0	8.0
06M050080DLWN	M5	0.8	22.2	11.1
06M060100DLWN	M6	1.0	29.7	13.4

METRIC WASHERS AND SCREW INSULATORS

SECTION
XIV

ALL DIMENSIONS ARE IN MILLIMETERS

LOCKING AND SEALING WASHERS

Molded in **Natural Nylon 6/6**

Micro Plastics locking and sealing washers are made of natural nylon 6/6. This washer's unique geometry creates an interference both on the OD of a hex nut, and on the ID on the shanks or thread of the screw. As the screw is tightened, the OD cold flows around the hex of a nut, and the ID cold flows into the threads of the bolt or screw.

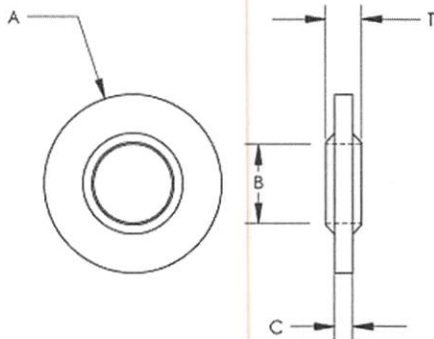
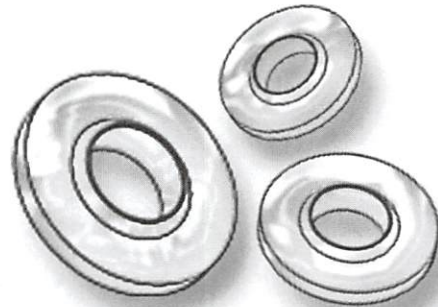

PART DESIGN A

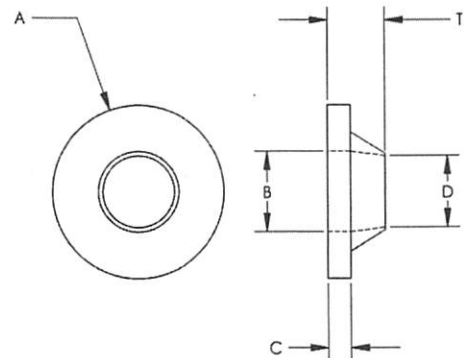

PART DESIGN B

ITEM NUMBER	SCREW SIZE		DESIGN TYPE	ID B	SHANK ID D	OD A	WASHER	
	METRIC	INCH					THICKNESS C	THICKNESS T
16MLSW030070070	M3	#5	A	3.10 MM		7.00 MM	0.70 MM	1.40 MM
16MLSW040090125	M4	#8	A	4.15 MM		9.00 MM	1.25 MM	1.25 MM
16MLSW050104140	M5	#10	A	5.15 MM		10.40 MM	1.40 MM	3.50 MM
16MLSW060120160	M6		A	6.10 MM		12.00 MM	1.60 MM	4.00 MM
16MLSW080158210	M8	5/16	A	8.10 MM		15.80 MM	2.10 MM	4.60 MM
16MLSW100196210	M10	3/8	A	10.00 MM		19.60 MM	2.10 MM	5.30 MM
16MLSW140252250	M14	9/16	A	14.00 MM		25.20 MM	2.50 MM	5.50 MM
16MLSW042090120	M4.2		B	4.20 MM	4.20 MM	9.00 MM	1.20 MM	3.00 MM
16MLSW048100150	M4.8		B	4.80 MM	4.80 MM	10.00 MM	1.50 MM	3.20 MM
16MLSW060125150	M6		B	6.30 MM	6.30 MM	12.50 MM	1.50 MM	2.80 MM
16MLSW080160160	M8		B	8.20 MM	8.20 MM	16.00 MM	1.60 MM	3.10 MM
* 16MLSW103150200		R 1/8	B	10.30 MM	9.45 MM	15.00 MM	2.00 MM	4.00 MM
* 16MLSW132190250		R 1/4	B	13.20 MM	12.20 MM	19.00 MM	2.50 MM	4.50 MM

* WHITWORTH TAPERED PIPE THREAD

METRIC WASHERS AND SCREW INSULATORS

ALL DIMENSIONS ARE IN MILLIMETERS

SECTION
XIV

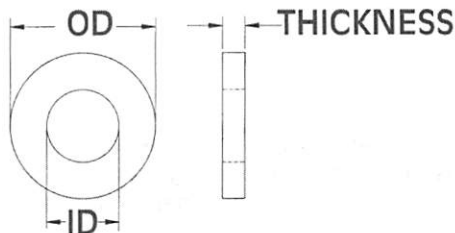

STANDARD WASHERS - DIN 34815

Molded in Natural Nylon 6/6

ITEM NUMBER	THREAD SIZE	MAX. OD	MIN. OD	MAX. ID	MIN. ID	MAX. THICKNESS	MIN. THICKNESS
17M04DIN34815	M4	9 MM	8.64 MM	4.48 MM	4.3 MM	0.9 MM	0.7 MM
17M05DIN34815	M5	10 MM	9.64 MM	5.48 MM	5.3 MM	1.1 MM	0.9 MM
17M06DIN34815	M6	12 MM	11.57 MM	6.62 MM	6.4 MM	1.8 MM	1.4 MM
17M08DIN34815	M8	16 MM	15.57 MM	8.62 MM	8.4 MM	1.8 MM	1.4 MM
17M10DIN34815	M10	20 MM	19.48 MM	10.77 MM	10.5 MM	2.2 MM	1.8 MM
17M12DIN34815	M12	24 MM	23.48 MM	13.27 MM	13 MM	2.7 MM	2.3 MM
17M16DIN34815	M16	30 MM	29.48 MM	17.27 MM	17 MM	3.3 MM	2.7 MM
17M20DIN34815	M20	37 MM	36.38 MM	21.33 MM	21 MM	3.3 MM	2.7 MM

LARGE WASHERS - DIN 34816

Molded in Natural Nylon 6/6

ITEM NUMBER	THREAD SIZE	MAX. OD	MIN. OD	MAX. ID	MIN. ID	MAX. THICKNESS	MIN. THICKNESS
17M03DIN34816	M3	9 MM	8.64 MM	3.38 MM	3.2 MM	0.9 MM	0.7 MM
17M04DIN34816	M4	12 MM	11.57 MM	4.48 MM	4.3 MM	1.1 MM	0.9 MM
17M05DIN34816	M5	15 MM	14.57 MM	5.48 MM	5.3 MM	1.4 MM	1.0 MM
17M06DIN34816	M6	18 MM	17.57 MM	6.62 MM	6.4 MM	1.8 MM	1.4 MM
17M08DIN34816	M8	24 MM	23.48 MM	8.62 MM	8.4 MM	2.2 MM	1.8 MM
17M10DIN34816	M10	30 MM	29.48 MM	10.77 MM	10.5 MM	2.7 MM	2.3 MM
17M12DIN34816	M12	37 MM	36.38 MM	13.27 MM	13 MM	3.3 MM	2.7 MM
17M16DIN34816	M16	50 MM	49.38 MM	17.27 MM	17 MM	3.3 MM	2.7 MM

FLAT WASHERS

Molded in Natural Nylon 6/6

ITEM NUMBER	THREAD SIZE	OD	ID	THICKNESS
16M02050080	M2	5.00 MM	2.15 MM	0.80 MM
16M02556080	M2.5	5.60 MM	2.65 MM	0.80 MM
16M03080080	M3	8.00 MM	3.20 MM	0.80 MM
16M03580080	M3.5	8.00 MM	3.70 MM	0.80 MM
16M04080200	M4	8.00 MM	4.30 MM	2.00 MM
16M04090080	M4	9.00 MM	4.30 MM	0.80 MM
16M05011100	M5	11.00 MM	5.30 MM	1.00 MM
16M06012150	M6	12.00 MM	6.40 MM	1.50 MM
16M08018200	M8	18.00 MM	8.40 MM	2.00 MM
16M08525200	M8.5	25.00 MM	8.50 MM	2.00 MM
16M10022250	M10	22.00 MM	10.50 MM	2.50 MM
16M12025200	M12	25.14 MM	13.43 MM	2.53 MM
16M12034250	M12	33.64 MM	13.40 MM	3.06 MM
16M70074500	M64	74.50 MM	70.00 MM	5.00 MM



METRIC WASHERS AND SCREW INSULATORS

SECTION
XIV

ALL DIMENSIONS ARE IN MILLIMETERS

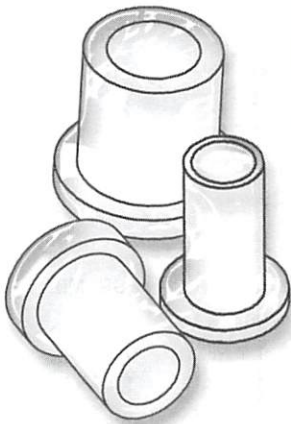

Nylon Screw Insulators are used to isolate metal screws electrically as well as to reduce corrosion. They can be used as light load bearings in many applications. Specials can be made to order for small tool charge. Specify the screw size and length when ordering.



SIZES NOT SHOWN WILL BE TOOLED UPON REQUEST

SCREW INSULATORS

Molded in **Natural Nylon 6/6**

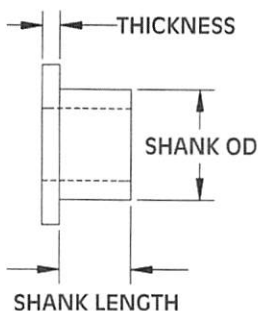
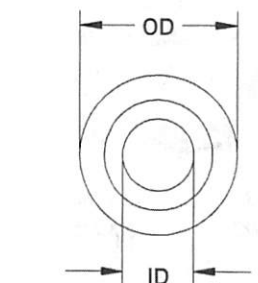

ITEM NUMBER	DESCRIPTION	SHANK LENGTH	OD	THICKNESS	SHANK OD	ID
10SCM002003	SCM 2 X 3	3 MM	4.2 MM	1.0 MM	3.0 MM	2.1 MM
10SCM002004	SCM 2 X 4	4 MM	4.2 MM	1.0 MM	3.0 MM	2.1 MM
10SCM002005	SCM 2 X 5	5 MM	4.2 MM	1.0 MM	3.0 MM	2.1 MM
10SCM002006	SCM 2 X 6	6 MM	4.2 MM	1.0 MM	3.0 MM	2.1 MM
10SCM003001	SCM 3 X 1	1 MM	6.2 MM	1.0 MM	4.0 MM	3.1 MM
10SCM003002	SCM 3 X 2	2 MM	6.2 MM	1.0 MM	4.0 MM	3.1 MM
10SCM003003	SCM 3 X 3	3 MM	6.2 MM	1.0 MM	4.0 MM	3.1 MM
10SCM003004	SCM 3 X 4	4 MM	6.2 MM	1.0 MM	4.0 MM	3.1 MM
10SCM003005	SCM 3 X 5	5 MM	6.2 MM	1.0 MM	4.0 MM	3.1 MM
10SCM003006	SCM 3 X 6	6 MM	6.2 MM	1.0 MM	4.0 MM	3.1 MM
10SCM003007	SCM 3 X 7	7 MM	6.2 MM	1.0 MM	4.0 MM	3.1 MM
10SCM003008	SCM 3 X 8	8 MM	6.2 MM	1.0 MM	4.0 MM	3.1 MM
10SCM003009	SCM 3 X 9	9 MM	6.2 MM	1.0 MM	4.0 MM	3.1 MM
10SCM003010	SCM 3 X 10	10 MM	6.2 MM	1.0 MM	4.0 MM	3.1 MM
10SCM004003	SCM 4 X 3	3 MM	8.4 MM	1.5 MM	6.0 MM	4.1 MM
10SCM004004	SCM 4 X 4	4 MM	8.4 MM	1.5 MM	6.0 MM	4.1 MM
10SCM004005	SCM 4 X 5	5 MM	8.4 MM	1.5 MM	6.0 MM	4.1 MM
10SCM004007	SCM 4 X 7	7 MM	8.4 MM	1.5 MM	6.0 MM	4.1 MM
10SCM004009	SCM 4 X 9	9 MM	8.4 MM	1.5 MM	6.0 MM	4.1 MM
10SCM005003	SCM 5 X 3	3 MM	10.2 MM	2.0 MM	7.0 MM	5.1 MM
10SCM005004	SCM 5 X 4	4 MM	10.2 MM	2.0 MM	7.0 MM	5.1 MM
10SCM005005	SCM 5 X 5	5 MM	10.2 MM	2.0 MM	7.0 MM	5.1 MM
10SCM005007	SCM 5 X 7	7 MM	10.2 MM	2.0 MM	7.0 MM	5.1 MM
10SCM005009	SCM 5 X 9	9 MM	10.2 MM	2.0 MM	7.0 MM	5.1 MM
10SCM006004	SCM 6 X 4	4 MM	12.2 MM	2.0 MM	8.0 MM	6.1 MM
10SCM006006	SCM 6 X 6	6 MM	12.2 MM	2.0 MM	8.0 MM	6.1 MM
10SCM006008	SCM 6 X 8	8 MM	12.2 MM	2.0 MM	8.0 MM	6.1 MM
10SCM006010	SCM 6 X 10	10 MM	12.2 MM	2.0 MM	8.0 MM	6.1 MM
10SCM006012	SCM 6 X 12	12 MM	12.2 MM	2.0 MM	8.0 MM	6.1 MM
10SCM008004	SCM 8 X 4	4 MM	14.2 MM	2.5 MM	10.0 MM	8.1 MM
10SCM008006	SCM 8 X 6	6 MM	14.2 MM	2.5 MM	10.0 MM	8.1 MM
10SCM008008	SCM 8 X 8	8 MM	14.2 MM	2.5 MM	10.0 MM	8.1 MM
10SCM008010	SCM 8 X 10	10 MM	14.2 MM	2.5 MM	10.0 MM	8.1 MM
10SCM008012	SCM 8 X 12	12 MM	14.2 MM	2.5 MM	10.0 MM	8.1 MM

METRIC SPACERS

ALL DIMENSIONS ARE IN MILLIMETERS

SECTION
XV

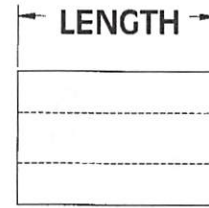
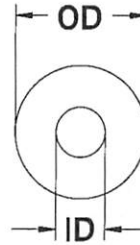

METRIC SPACERS

Molded in **Black Heat Stabilized Nylon**

ITEM NUMBER	DESC.	OD	ID	LENGTH	ITEM NUMBER	DESC.	OD	ID	LENGTH
13ME001	ME 1	4 MM	2.6 MM	2 MM	13ME069	ME 69	10 MM	6.3 MM	5 MM
13ME002	ME 2	4 MM	2.6 MM	3 MM	13ME070	ME 70	10 MM	6.3 MM	7.5 MM
13ME003	ME 3	4 MM	2.6 MM	5 MM	13ME071	ME 71	10 MM	6.3 MM	10 MM
13ME004	ME 4	4 MM	2.6 MM	7.5 MM	13ME072	ME 72	10 MM	6.3 MM	15 MM
13ME005	ME 5	4 MM	2.6 MM	10 MM	13ME073	ME 73	10 MM	6.3 MM	20 MM
13ME006	ME 6	4 MM	2.6 MM	15 MM	13ME074	ME 74	10 MM	6.3 MM	25 MM
13ME007	ME 7	4 MM	2.6 MM	20 MM	13ME075	ME 75	10 MM	6.3 MM	30 MM
13ME010	ME 10	5 MM	2.6 MM	2 MM	13ME076	ME 76	15 MM	6.5 MM	3 MM
13ME011	ME 11	5 MM	2.6 MM	3 MM	13ME077	ME 77	15 MM	6.5 MM	5 MM
13ME012	ME 12	5 MM	2.6 MM	5 MM	13ME078	ME 78	15 MM	6.5 MM	7.5 MM
13ME013	ME 13	5 MM	2.6 MM	7.5 MM	13ME079	ME 79	15 MM	6.5 MM	10 MM
13ME014	ME 14	5 MM	2.6 MM	10 MM	13ME080	ME 80	15 MM	6.5 MM	15 MM
13ME015	ME 15	5 MM	2.6 MM	15 MM	13ME081	ME 81	15 MM	6.5 MM	20 MM
13ME016	ME 16	5 MM	2.6 MM	20 MM	13ME083	ME 83	15 MM	6.5 MM	30 MM
13ME019	ME 19	5 MM	3.2 MM	2 MM	13ME084	ME 84	12 MM	8.3 MM	3 MM
13ME020	ME 20	5 MM	3.2 MM	3 MM	13ME085	ME 85	12 MM	8.3 MM	5 MM
13ME021	ME 21	5 MM	3.2 MM	5 MM	13ME086	ME 86	12 MM	8.3 MM	7.5 MM
13ME022	ME 22	5 MM	3.2 MM	7.5 MM	13ME087	ME 87	12 MM	8.3 MM	10 MM
13ME023	ME 23	5 MM	3.2 MM	10 MM	13ME088	ME 88	12 MM	8.3 MM	15 MM
13ME024	ME 24	5 MM	3.2 MM	15 MM	13ME089	ME 89	12 MM	8.3 MM	20 MM
13ME025	ME 25	5 MM	3.2 MM	20 MM	13ME091	ME 91	12 MM	8.3 MM	30 MM
13ME028	ME 28	6 MM	3.2 MM	3 MM	13ME092	ME 92	18 MM	8.3 MM	3 MM
13ME029	ME 29	6 MM	3.2 MM	5 MM	13ME093	ME 93	18 MM	8.3 MM	5 MM
13ME030	ME 30	6 MM	3.2 MM	7.5 MM	13ME094	ME 94	18 MM	8.3 MM	7.5 MM
13ME031	ME 31	6 MM	3.2 MM	10 MM	13ME095	ME 95	18 MM	8.3 MM	10 MM
13ME032	ME 32	6 MM	3.2 MM	15 MM	13ME096	ME 96	18 MM	8.3 MM	15 MM
13ME033	ME 33	6 MM	3.2 MM	20 MM	13ME097	ME 97	18 MM	8.3 MM	20 MM
13ME036	ME 36	8 MM	3.2 MM	3 MM	13ME098	ME 98	18 MM	8.3 MM	25 MM
13ME037	ME 37	8 MM	3.2 MM	5 MM	13ME099	ME 99	18 MM	8.3 MM	30 MM
13ME038	ME 38	8 MM	3.2 MM	7.5 MM	13ME100	ME100	15 MM	10.4MM	3 MM
13ME039	ME 39	8 MM	3.2 MM	10 MM	13ME101	ME101	15 MM	10.4MM	5 MM
13ME040	ME 40	8 MM	3.2 MM	15 MM	13ME102	ME102	15 MM	10.4MM	7.5 MM
13ME041	ME 41	8 MM	3.2 MM	20 MM	13ME103	ME103	15 MM	10.4MM	10 MM
13ME044	ME 44	6 MM	3.6 MM	3 MM	13ME104	ME104	15 MM	10.4MM	15 MM
13ME045	ME 45	6 MM	3.6 MM	5 MM	13ME105	ME105	15 MM	10.4MM	20 MM
13ME046	ME 46	6 MM	3.6 MM	7.5 MM	13ME108	ME108	22 MM	10.4MM	5 MM
13ME047	ME 47	6 MM	3.6 MM	10 MM	13ME109	ME109	22 MM	10.4MM	10 MM
13ME048	ME 48	6 MM	3.6 MM	15 MM	13ME110	ME110	22 MM	10.4MM	15 MM
13ME049	ME 49	6 MM	3.6 MM	20 MM	13ME111	ME111	22 MM	10.4MM	20 MM
13ME052	ME 52	8 MM	4.3 MM	3 MM	13ME118	ME118	18 MM	13.3MM	3 MM
13ME053	ME 53	8 MM	4.3 MM	5 MM	13ME119	ME119	18 MM	13.3MM	5 MM
13ME054	ME 54	8 MM	4.3 MM	7.5 MM	13ME120	ME120	18 MM	13.3MM	7.5 MM
13ME055	ME 55	8 MM	4.3 MM	10 MM	13ME121	ME121	18 MM	13.3MM	10 MM
13ME056	ME 56	8 MM	4.3 MM	15 MM	13ME122	ME122	18 MM	13.3MM	15 MM
13ME057	ME 57	8 MM	4.3 MM	20 MM	13ME123	ME123	18 MM	13.3MM	20 MM
13ME060	ME 60	10 MM	5.3 MM	3 MM	13ME124	ME124	18 MM	13.3MM	25 MM
13ME061	ME 61	10 MM	5.3 MM	5 MM	13ME126	ME126	25 MM	13.3MM	5 MM
13ME062	ME 62	10 MM	5.3 MM	7.5 MM	13ME127	ME127	25 MM	13.3MM	10 MM
13ME063	ME 63	10 MM	5.3 MM	10 MM	13ME128	ME128	25 MM	13.3MM	15 MM
13ME064	ME 64	10 MM	5.3 MM	15 MM	13ME129	ME129	25 MM	13.3MM	20 MM
13ME065	ME 65	10 MM	5.3 MM	20 MM	13ME132	ME132	10 MM	6.3 MM	28 MM
13ME068	ME 68	10 MM	6.3 MM	3 MM					



→ MNC 93657A091

METRIC SPACERS

SECTION
XV

ALL DIMENSIONS ARE IN MILLIMETERS

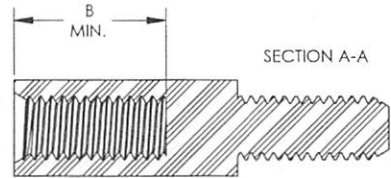
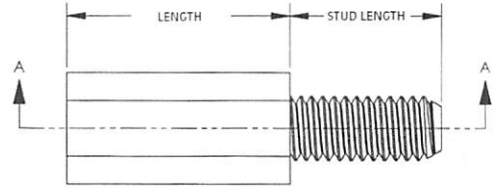
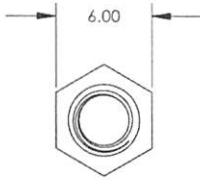
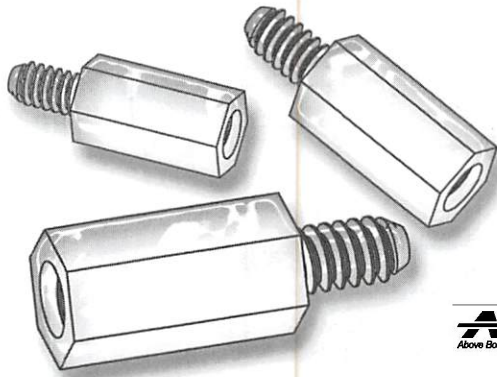

www.aboveboardelectronics.com
1-800-453-1692

METRIC MALE FEMALES

Molded in Natural Nylon 6/6

ITEM NUMBER	SCREW SIZE	THREAD	LENGTH	STUD LENGTH	B MIN. THREAD DEPTH
36M30MF006	M3	0.5	6 MM	4.76 MM	4 MM
36M30MF008	M3	0.5	8 MM	4.76 MM	4.76 MM
36M30MF010	M3	0.5	10 MM	4.76 MM	4.76 MM
36M30MF011	M3	0.5	11 MM	4.76 MM	4.76 MM
36M30MF012	M3	0.5	12 MM	4.76 MM	4.76 MM
36M30MF013	M3	0.5	13 MM	4.76 MM	4.76 MM
36M30MF014	M3	0.5	14 MM	4.76 MM	4.76 MM
36M30MF016	M3	0.5	16 MM	4.76 MM	4.76 MM
36M30MF019	M3	0.5	19 MM	4.76 MM	4.76 MM
36M30MF020	M3	0.5	20 MM	4.76 MM	4.76 MM
36M30MF022	M3	0.5	22 MM	4.76 MM	4.76 MM
36M30MF025	M3	0.5	25 MM	4.76 MM	4.76 MM
36M35MF008	M3.5	0.6	8 MM	6.35 MM	6 MM
36M35MF010	M3.5	0.6	10 MM	6.35 MM	6.35 MM
36M35MF011	M3.5	0.6	11 MM	6.35 MM	6.35 MM
36M35MF012	M3.5	0.6	12 MM	6.35 MM	6.35 MM
36M35MF013	M3.5	0.6	13 MM	6.35 MM	6.35 MM
36M35MF014	M3.5	0.6	14 MM	6.35 MM	6.35 MM
36M35MF016	M3.5	0.6	16 MM	6.35 MM	6.35 MM
36M35MF019	M3.5	0.6	19 MM	6.35 MM	6.35 MM
36M35MF020	M3.5	0.6	20 MM	6.35 MM	6.35 MM
36M35MF022	M3.5	0.6	22 MM	6.35 MM	6.35 MM
36M35MF025	M3.5	0.6	25 MM	6.35 MM	6.35 MM
36M40MF010	M4	0.7	10 MM	8 MM	8 MM
36M40MF011	M4	0.7	11 MM	9.53 MM	9 MM
36M40MF012	M4	0.7	12 MM	9.53 MM	9.53 MM
36M40MF013	M4	0.7	13 MM	9.53 MM	9.53 MM
36M40MF014	M4	0.7	14 MM	9.53 MM	9.53 MM
36M40MF015	M4	0.7	15 MM	9.53 MM	9.53 MM
36M40MF016	M4	0.7	16 MM	9.53 MM	9.53 MM
36M40MF018	M4	0.7	18 MM	9.53 MM	9.53 MM
36M40MF019	M4	0.7	19 MM	9.53 MM	9.53 MM
36M40MF020	M4	0.7	20 MM	9.53 MM	9.53 MM
36M40MF022	M4	0.7	22 MM	9.53 MM	9.53 MM
36M40MF025	M4	0.7	25 MM	9.53 MM	9.53 MM



METRIC SPACERS

ALL DIMENSIONS ARE IN MILLIMETERS

SECTION
XV

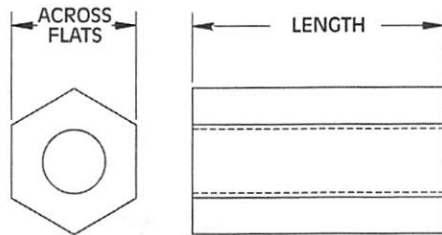

HEX SPACERS

Molded in Natural Nylon 6/6

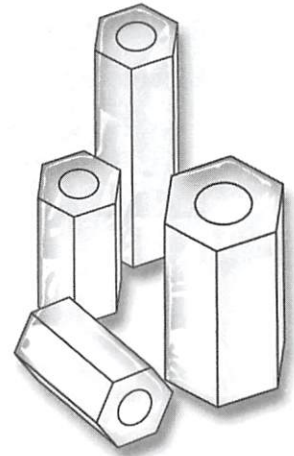

ITEM NUMBER	SELF TAPPING ID	SCREW SIZE	LENGTH	ACROSS FLATS
35MHSP004	2.62MM	M3	20MM	6MM
35MHSP006	3.56MM	M4	6MM	6MM
35MHSP008	3.56MM	M4	8MM	6MM
35MHSP010	3.56MM	M4	10MM	6MM
35MHSP012	3.56MM	M4	12MM	6MM
35MHSP015	3.56MM	M4	15MM	6MM
35MHSP018	3.56MM	M4	18MM	6MM
35MHSP020	3.56MM	M4	20MM	6MM
35MHSP025	3.56MM	M4	25MM	6MM

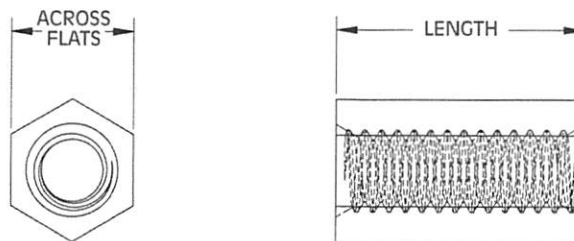

Parts longer than 19MM will be tapped 9.5MM deep on both ends.

HEX TAPPED SPACERS

Molded in Natural Nylon 6/6

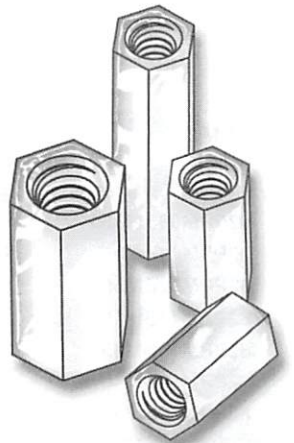

ITEM NUMBER	THREAD	SCREW SIZE	LENGTH	ACROSS FLATS
14MMHTSP004	M3X0.5	M3	20MM	6MM
14MMHTSP006	M4X0.7	M4	6MM	6MM
14MMHTSP008	M4X0.7	M4	8MM	6MM
14MMHTSP010	M4X0.7	M4	10MM	6MM
14MMHTSP012	M4X0.7	M4	12MM	6MM
14MMHTSP015	M4X0.7	M4	15MM	6MM
14MMHTSP018	M4X0.7	M4	18MM	6MM
14MMHTSP020	M4X0.7	M4	20MM	6MM
14MMHTSP025	M4X0.7	M4	25MM	6MM

METRIC PANEL FASTENERS AND HOLE PLUGS

SECTION
XVI

ALL DIMENSIONS ARE IN MILLIMETERS

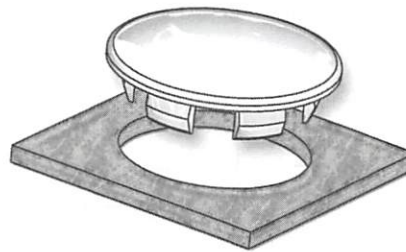
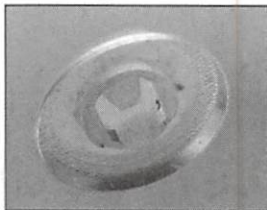
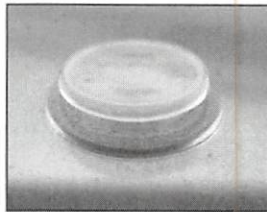

Micro Plastics' economical metric snap-in poly-plugs will close unneeded holes, wiring, outlets, fill unused accessory openings, cover inspection and production access holes. They can be used as tube end caps and protective bumpers. Metric poly plugs are molded in Nylon 6/6 which is corrosion, abrasion and vibration resistant, making them ideal for drawer glides and small appliance feet. Poly plugs are designed with special flexible and tapered prongs which snugly lock in place with finger pressure but can be removed and reused when necessary. Poly plugs have a dull matte finish and are stocked in natural nylon. Dyed and molded colors are available in volume requirements.

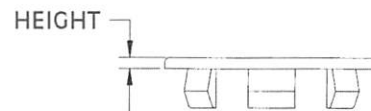
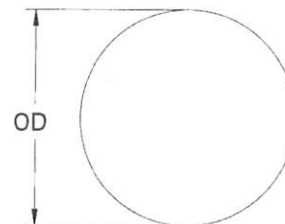
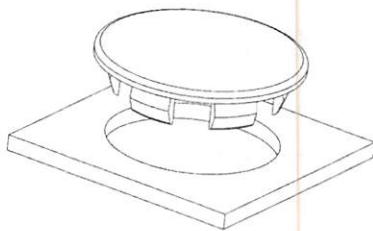

METRIC HOLE PLUGS

Molded in **Natural Nylon 6/6**

ITEM NUMBER	HEAD STYLE	FINISH	HOLE SIZE RND	PANEL THICKNESS	OD	HEIGHT
62PPM06BM16	Binder	Matte	6 MM	0.8-1.6 MM	10.0 MM	2.0 MM
62PPM08BM35	Binder	Matte	8 MM	0.8-3.5 MM	12.0 MM	2.0 MM
62PPM10BM35	Binder	Matte	10 MM	0.8-3.5 MM	14.0 MM	2.0 MM
62PPM12BM35	Binder	Matte	12 MM	0.8-3.5 MM	16.0 MM	2.0 MM
62PPM14BM35	Binder	Matte	14 MM	0.8-3.5 MM	18.0 MM	2.0 MM
62PPM16BM35	Binder	Matte	16 MM	0.8-3.5 MM	20.0 MM	2.0 MM
62PPM18BM40	Binder	Matte	18 MM	0.8-4.0 MM	22.0 MM	2.0 MM
62PPM20BM40	Binder	Matte	20 MM	0.8-4.0 MM	26.0 MM	2.0 MM
62PPM22BM40	Binder	Matte	22 MM	0.8-4.0 MM	27,8 MM	2.0 MM
62PPM24BM40	Binder	Matte	24 MM	0.8-4.0 MM	28.0 MM	2.0 MM
62PPM26BM40	Binder	Matte	26 MM	0.8-4.0 MM	30.0 MM	2.0 MM

METRIC PANEL FASTENERS AND HOLE PLUGS

ALL DIMENSIONS ARE IN MILLIMETERS

SECTION
XVI

METRIC XMAS TREE TYPE CLIPS

Molded in **Black Nylon 6/6**

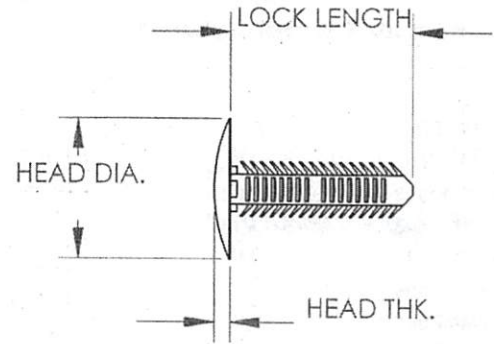
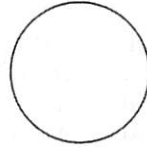

PART NUMBER	HOLE SIZE	PANEL THICKNESS RANGE	HEAD DIAMETER	HEAD THICKNESS	LOCK LENGTH
27MXT003003	3MM	1.6MM-3MM	8.39 MM	1.57 MM	4.85 MM
27MXT003006	3MM	1.6MM-6MM	8.39 MM	1.57 MM	7.57 MM
27MXT003010	3MM	1.6MM-6MM	8.39 MM	1.57 MM	11.66 MM
27MXT004006	4MM	1.6MM-6MM	11.18 MM	1.98 MM	8.33 MM
27MXT004010	4MM	1.6MM-10MM	11.18 MM	1.98 MM	12.24 MM
27MXT005006	5MM	1.6MM-6MM	13.97 MM	1.98 MM	8.53 MM
27MXT005010	5MM	1.6MM-10MM	13.97 MM	1.98 MM	12.29 MM
27MXT005026	5MM	1.6MM-26MM	13.97 MM	1.98 MM	28.35 MM
27MXT006006	6MM	1.6MM-6MM	16.78 MM	1.98 MM	9.27 MM
27MXT006018	6MM	1.6MM-18MM	16.78 MM	1.98 MM	21.31 MM
27MXT006050	6MM	1.6MM-50MM	16.78 MM	1.98 MM	53.70 MM

METRIC WIRE HANDLING HARDWARE

ALL DIMENSIONS ARE IN MILLIMETERS

SECTION
XVII

Micro Plastics' Wire/Cable Holders are designed to mount into 5mm hole diameters. Wire/Cable Holders can be used in a variety of panel thicknesses and materials. Sizes are available to handle wire bundle diameters from 9.5mm to 12.7mm.

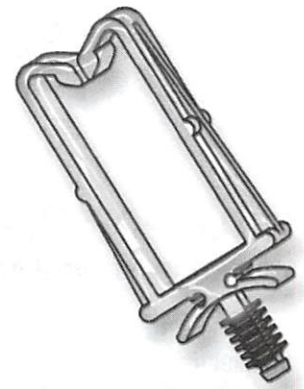
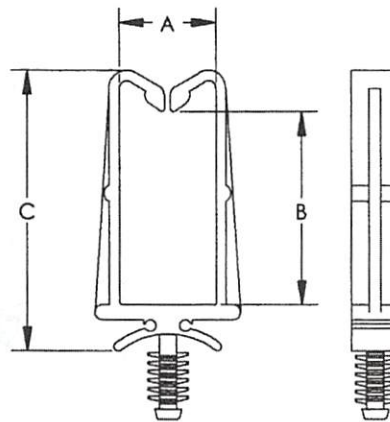
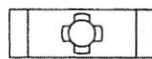

WIRE/CABLE HOLDERS

Molded in **Natural Nylon 6/6**

ITEM NUMBER	A	B	C	HOLE DIA.	PANEL RANGE
22MWA095127	9.5	12.7	23.4	5MM	VARIABLE
22MWA095190	9.5	19.0	29.8	5MM	VARIABLE
22MWA127190	12.7	19.0	30.5	5MM	VARIABLE
22MWA127254	12.7	25.4	37.3	5MM	VARIABLE

METRIC CIRCUIT BOARD HARDWARE

SECTION
XVIII

ALL DIMENSIONS ARE IN MILLIMETERS

MINIATURE SUPPORT POSTS

Molded in Natural Nylon 6/6

ITEM NUMBER	A
27MMP002	2 MM
27MMP003	3 MM
27MMP003A	3.5 MM
27MMP004	4 MM
27MMP005	5 MM
27MMP006	6 MM
27MMP008	8 MM
27MMP010	10 MM
27MMP012	12 MM
27MMP014	14 MM
27MMP016	16 MM
27MMP018	18 MM
27MMP020	20 MM
27MMP022	22 MM

Economical locking spacers eliminate screws, nuts, and lock washers in mounting P.C. Boards on metal chassis or stacking in multiple tiers. Unique locking clips provide a mechanically secure, reusable connection in predrilled or punched holes while saving considerable assembly time. The new metric supports are designed for 2.5mm diameter holes and 1.57 mm thick panels. Lengths from 2mm to 22mm available.

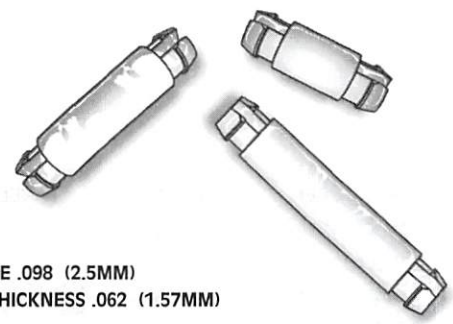
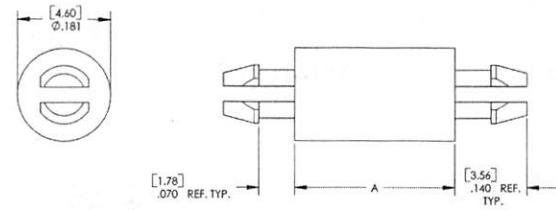

NOTE: HOLE SIZE .098 (2.5MM)
PANEL THICKNESS .062 (1.57MM)

New Product Line

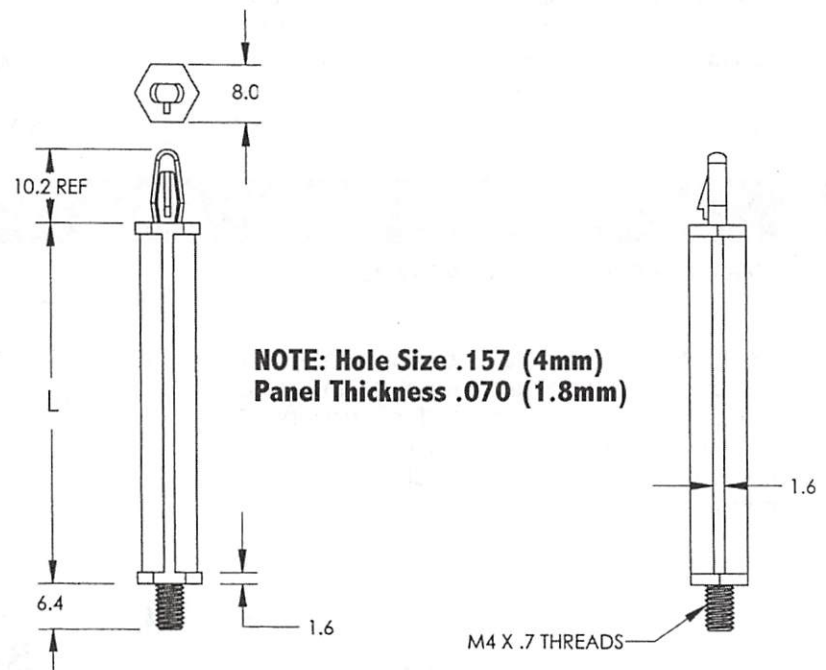

NOTE: Hole Size .157 (4mm)
Panel Thickness .070 (1.8mm)

MALE PCB SUPPORT POSTS

Molded in Natural Nylon 6/6

ITEM NUMBER	DESCRIPTION	L
27MLMTP45	MLMTP 45	45 MM
27MLMTP50	MLMTP 50	50 MM

METRIC FASTENER ASSORTMENT KITS

SECTION
XIX

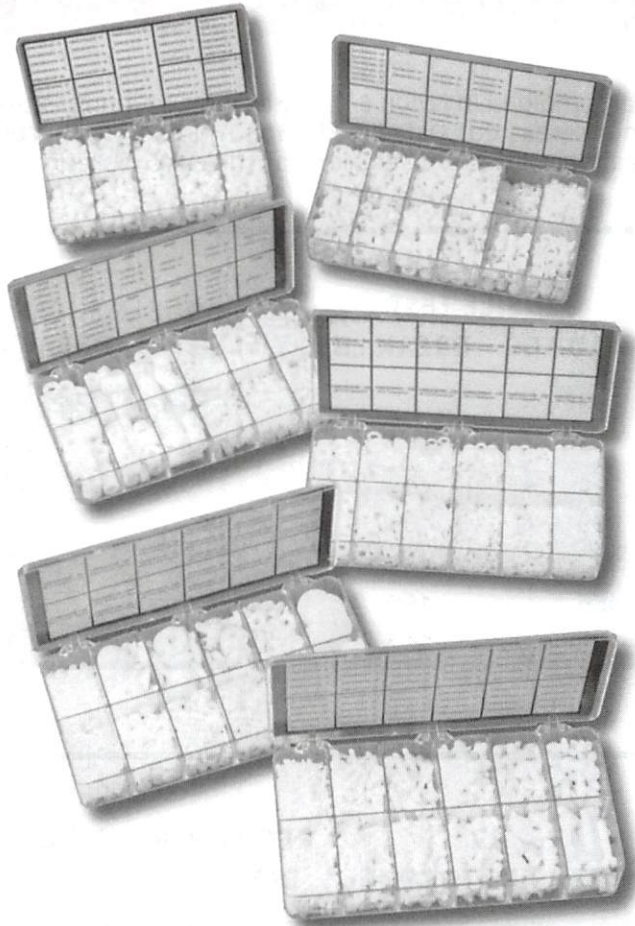

MOLDED NYLON FASTENERS PROVIDE ELECTRICAL INSULATION, VIBRATION AND CORROSION RESISTANCE. HAVE A LOW THERMAL CONDUCTIVITY, ARE NON-MAGNETIC AND HAVE A HIGH STRENGTH-TO-WEIGHT RATIO. PACKAGED IN LARGE REUSABLE TRANSPARENT PLASTIC STORAGE BOXES.

IDEAL FOR:

- PROTOTYPE WORK** - Large working assortments.
- PRODUCT DESIGN** - Latest designs for increased productivity.
- MODEL MAKING** - Commercially available standard parts.
- SHOP AND MAINTENANCE** - Convenient selection.



www.aboveboardelectronics.com
1-800-453-1692

O4ASO965MSM MACHINE SCREWS

**OVER 950 NYLON FASTENERS
OVER 60 DIFFERENT
SIZES AND TYPES**

Assortment Kit Consists of Approximately:

- 220 - M2 X 4MM to 25MM Long
- 170 - M2.5 X 4MM to 25MM Long
- 115 - M3 X 5MM to 25MM Long
- 110 - M3.5 X 5MM to 25MM Long
- 130 - M4 X 6MM to 25MM Long
- 135 - M5 X 6MM to 25MM Long
- 85 - M6 X 5MM to 25MM Long

O4ASO4115FWM FLAT WASHERS

OVER 700 NYLON FASTENERS

Assortment Kit Consists of Approximately:

- 900 - M2 Flat Washers
- 825 - M2.5 Flat Washers
- 700 - M3 Flat Washers
- 650 - M3.5 Flat Washers
- 570 - M4 Flat Washers
- 300 - M5 Flat Washers
- 170 - M6 Flat Washers

O4ASO690SPM SPACERS

**OVER 600 NYLON FASTENERS
OVER 30 DIFFERENT SIZES AND TYPES**

Assortment Kit Consists of Approximately:

- 105 - M2 X 3MM to 25MM Long
- 95 - M2.5 X 3MM to 25MM Long
- 80 - M3 X 3MM to 25MM Long
- 150 - M3.5 X 3MM to 10MM Long
- 110 - M4 X 3MM to 25MM Long
- 50 - M5 X 3MM to 25MM Long
- 55 - M6 X 3MM to 25MM Long

O4ASO655MMN MACHINE SCREWS & NUTS

**OVER 655
NYLON FASTENERS
OVER 30 DIFFERENT
SIZES AND TYPES**

Slotted Cheese Head, Hex Head, Fillister Head and 90° Flat Head Styles, MACHINE SCREWS in sizes;

Assortment Kit Consists of Approximately:

- 100 - M3 X 5 X 6 to 25MM
- 100 - M3.5 X 6 X 5 to 25MM
- 100 - M4 X 7 X 6 to 16MM
- 100 - M5 X 8 X 6 to 16MM
- 30 - M6 X 1.00 X 8 to 16MM
- 200 - Metric Nuts & Washers

O4ASO705SCM SCREW INSULATORS

**OVER 700
NYLON FASTENERS
OVER 20 DIFFERENT
SIZES AND TYPES**

Assortment Kit Consists of Approximately:

- 150 - M2 Screw Insulators
- 125 - M3 Screw Insulators
- 200 - M4 Screw Insulators
- 125 - M5 Screw Insulators
- 105 - M6 Screw Insulators

O4ASO700SWSM SHOULDER WASHERS

**OVER 1000
NYLON FASTENERS
OVER 20 DIFFERENT
SIZES AND TYPES**

Assortment Kit Consists of Approximately:

- 315 - M2 Shoulder Washers
- 245 - M3 Shoulder Washers
- 180 - M4 Shoulder Washers
- 225 - M5 Shoulder Washers
- 105 - M6 Shoulder Washers



MICRO PLASTICS' MOLDED NYLON 6/6 FASTENERS

MECHANICAL TEST DATA - UNC - UNF

SECTION
XX
INFORMATION

Nylon 6/6 meets ASTM D4066/ASTM D6779

All tests performed per ASTM specifications. Parts molded in Nylon 6/6, dry as molded, unmoisturized, at 73° F/23° C. Results are average of random parts tested. Data listed is for informational purposes only and shall not be used to establish specifications, limits or used alone as the basis of design.

MACHINE SCREWS

SIZE	ULTIMATE TORQUE	MAX TORQUE BEFORE DEFORMATION	TENSILE TEST		DOUBLE SHEAR	
			YIELD LBS.	BREAK LBS.	YIELD LBS.	BREAK LBS.
256	NO TEST	NO TEST	16	19	NO TEST	
440	24 In Oz.	12-16 In Oz.	38	41	45	50
632	30 In Oz.	18-20 In Oz.	65	69	91	97
832	5 In Lbs.	2-3 In Lbs.	99	108	158	164
1024	6 In Lbs.	2-4 In Lbs.	139	149	187	257
1032	7 In Lbs.	3-4 In Lbs.	155	165	234	241
1/4-20	13 In Lbs.	9-10 In Lbs.	296	312	413	432

HEX NUTS

SIZE	#1 TENSILE LBS.	#2 TENSILE TORQUE	RECOMMENDED TORQUE BEFORE DEFORMATION
440	85	2 In Lbs.	1.5 In Lbs.
632	135	5.2 In Lbs.	4 In Lbs.
832	172	6.8 In Lbs.	5 In Lbs.
1024	211	7 In Lbs.	5.5 In Lbs.
1032	276	8 In Lbs.	6.5 In Lbs.
1/4-20	311	19.3 In Lbs.	17 In Lbs.
5/16-18	877	44.3 In Lbs.	42 In Lbs.
3/8-16	994	74 In Lbs.	72 In Lbs.
1/2-13	2,367	15.7 Ft Lbs.	13 Ft Lbs.
5/8-11	3,487	31.7 Ft.Lbs.	30 Ft Lbs.

Test #1 Pull Test -Nylon Nut on Metal Screw Test #2 Torque on Nylon Nut on Metal Screw

CAP SCREWS

SIZE	ULTIMATE TORQUE	MAX TORQUE BEFORE DEFORMATION	TENSILE TEST		DOUBLE SHEAR	
			YIELD LBS.	BREAK LBS.	YIELD LBS.	BREAK LBS.
1/4-20	19 In Lbs.	15-16 In Lbs.	200	228	413	432
5/16-18	37 In Lbs.	32-34 In Lbs.	403	424	866	880
3/8-16	49 In Lbs.	45-46 In Lbs.	480	513	1108	1173
1/2-13	11 Ft. Lbs.	7-8 Ft. Lbs.	1393	1425	2276	2313
5/8-11	22 Ft. Lbs.	18-19 Ft. Lbs.	2260	2303	3340	3410

MICRO PLASTICS' MOLDED NYLON 6/6 FASTENERS MECHANICAL TEST DATA - METRIC

SECTION
XX
INFORMATION

Data listed is for informational purposes only and shall not be used to establish specifications, limits or used alone as the basis of design.

MACHINE SCREWS

SIZE	ULTIMATE TORQUE	MAX TORQUE BEFORE DEFORMATION	TENSILE TEST		DOUBLE SHEAR	
			YIELD NEWTONS	BREAK NEWTONS	YIELD NEWTONS	BREAK NEWTONS
M2 X .4	NO TEST	NO TEST	7.12 N	2.14 N	89 N	116 N
M2.5 X .45	NO TEST	NO TEST	8.9 N	4.85 N	156 N	169 N
M3 X .5	.32 Nm	.2-.26 Nm	22 N	6.21 N	294 N	329 N
M3.5 X .6	.43 Nm	.28-.34 Nm	53 N	7.23 N	378 N	405 N
M4 X .7	.45 Nm	.36-.43 Nm	214 N	11.52 N	600 N	636 N
M5 X .8	.93 Nm	.73-.79 Nm	271 N	19.20 N	1081 N	1134 N
M6 X .1	1.83 Nm	1.41-1.47 Nm	845 N	0	1806 N	1877 N *
M8 X 1.25	3.39 Nm	2.45-2.82 Nm	1677 N	0	2980 N	3034 N *
M10 X 1.50	5.31 Nm	4.52 - 4.86 Nm	2749 N	79.31 N	5026 N	5280 N *

* PENDING REVIEW

HEX NUTS

SIZE	TENSILE	ULTIMATE TORQUE
M2	NO TEST	NO TEST
M2.5	135.23 N	NO TEST
M3	142.34 N	NO TEST
M3.5	369.20 N	2.3 CM/KG
M4	451.94 N	4.5 CM/KG
M5	940.35 N	8.3
M6	1556.65 N	17.6 CM/KG
M8	2597.76 N	56.2 CM/KG
M10	6283.11 N	89.93 CM/KG

FOR ADDITIONAL MATERIAL INFORMATION SEE OUR WEBSITE

<http://www.microplastics.com/Materials/Material%20list.htm>

NYLON 6/6 POLYAMIDE (PA)

General-purpose nylon 6/6 has good toughness, tensile strength, and resistance to creep, particularly in the high temperature range. Nylon has excellent wear properties, low coefficient of friction, and exceptional chemical resistance particularly to aromatic hydrocarbons, greases, and oils. Nylon is a hygroscopic material. Moisture acts as a plasticizer reducing the tensile strength, stiffness, and increasing elongation, impact strength, and energy absorbing characteristics. Outdoor weathering can be improved by the addition of carbon black. Nylon will perform well in long range service in most applications at temperatures as high as 185° F (85° C). Nylon is a translucent off white color.

APPLICATIONS

Fasteners - Bearings - Gears - Cams - Gaskets - Printed Circuit Board Hardware - Washers - Spacers - Insulators - Spiral Wrap - Flexible Grommets - Wire Ties - Electronic Components - Bushings - Wiring Clips - Cable Clamps - Hole Plugs - Hose Clamps

QUALIFICATIONS

Mil - M20693B "A" Type 1

LP410A

ASTM D4066 Type 1 Grade 2 Per ASTM D789

NYLON 6 HEAT STABILIZED

Nylon 6 heat stabilized has the same mechanical properties as general purpose nylon 6q with the additional advantage of heat stabilization this material can withstand 250° F (121° C) temperature in long range service in most applications. Heat stabilized nylon is off white in color.

APPLICATIONS

Fasteners - Bearings - Gears - Cams - Printed Circuit Board Hardware - Washers - Spacers - Insulators - Electronic Components - Bushings - Strain Relief - Hole Plugs - Wiring Clips - Hose Clamps.

NYLON 6/6 IMPACT MODIFIED

Nylon 6/6 impact modified has the additional advantage of very high impact strength at low temperatures and enhanced resistance to heat distortion over general purpose nylon 6/6. Impact nylon 6/6 is off white in color.

APPLICATIONS

Fasteners - Bearings - Gears - Cams - Printed Circuit Board Hardware - Washers - Spacers - Insulators - Electronic Components - Bushings - Requiring additional impact resistance.

NYLON 6/6 30% GLASSFILLED

Glass-Reinforced nylon has outstanding property improvements over unreinforced compositions. Improvements include greater tensile strength, deflection temperature, shear strength, improved creep resistance, better dimensional stability, and lower moisture absorption and thermal expansion. The good wear resistance, electrical properties and low coefficient of friction of nylon 6/6 un-reinforced are retained. 30% glass-filled nylon is opaque tan in color.

APPLICATIONS

Fasteners - Washers - Spacers - Insulators - Circuit Board Hardware - Requiring greater stiffness and strength.

NYLON 46 POLYAMIDE

High temperature nylon, which bridges the price performance gap between traditional nylons and high performance materials. Nylon 46 has excellent short term and long term heat resistance, high stiffness at elevated temperatures, high creep resistance, outstanding toughness, excellent fatigue behavior, good chemical resistance, and higher continuous-use temperature. Nylon 46 is translucent off white in color.

APPLICATIONS

Fasteners - Bearings - Cams - Gears - Printed Circuit Board Hardware - Washers - Spacers - Insulators - Electronic Components - Bushings - Wiring Clips - Cable Clamps - Hose Clamps.

NYLATRON GS

Nylon 66 with molybdenum disulphide (MOS2) solid lubricant added. Nylatron GS offers superior tensile and compressive strength, lower surface friction, higher heat resistance and greater dimensional stability than general purpose nylon 6/6. Nylatron is dark charcoal grey in color.

APPLICATIONS

Bushings - Bearings - Gears - Guides - Rollers - Washers

FOR ADDITIONAL MATERIAL INFORMATION SEE OUR WEBSITE

<http://www.microplastics.com/Materials/Material%20list.htm>

NYLON 66/6 COPOLYMER FLAME RETARDANT

Flame retardant nylon 66/6 has similar properties to general purpose 66 nylon with flame retardant additives for UL94V0 rating. Flame retardant nylon 6/6 is opaque off white in color.

APPLICATIONS

Fasteners - Printed Circuit Board Hardware - Washers - Spacers - Insulators - Electric Components - Bushings - Strain Reliefs - Cable Clamps - Wiring Clips.

ACETAL COPOLYMER (POM)

Acetal resins are characterized by their strength, stiffness, and hardness and are stable over a wide range of temperatures, humidity, environments, and stress. Acetal has high load bearing characteristics, excellent creep resistance, and low coefficient of friction. Acetal absorbs little water, minimizing the effect of moisture on its physical properties. Acetal resists neutral oils, grease, petroleum-based fuels, many organic solvents, and alkalis. Oxidizing agents and acids, organic and inorganic, with PH less than four attack acetals. Compared to nylon acetal has better fatigue resistance, creep resistance, stiffness and water resistance, but lower impact strength and abrasion resistance. Acetal is translucent off white in color. Acetal is widely used in plumbing and irrigation because it resists scale build - up and has excellent thread strength, creep resistance, and torque retention.

APPLICATIONS

Fasteners - Bearings - Gears - Cams - Washers - Spacers - Dowel Pins - Actuators

QUALIFICATIONS

NSF and FDA Approved.

HIGH-DENSITY POLYETHYLENE (HDPE)

Polyethylene is among the lowest density plastics and therefore is one of the lowest cost per cubic measure compared to other plastics. High density polyethylene has good toughness, excellent electrical properties, and chemical resistance, good low temperature brittleness and very low water absorption. Polyethylene is essentially inert, unaffected by strong and weak acids, alkalies, detergents, alcohols, and ketones. Polyethylene has low tensile strength and is subject to considerable creep and stress relaxation under load. Polyethylene will swell with chlorinated and aromatic hydrocarbons including gasoline and oils.

APPLICATIONS

Washers - Spacers - Beaded Ties - Insulators - Wire Clips - Protective Caps - Plugs - Spiral Wrap Flexible Grommeting

POLYCARBONATE (PC)

Polycarbonate is one of the toughest, most dimensionally stable thermoplastics over wide temperature range. Polycarbonate has exceptionally high impact strength. PC is unaffected by water below 140°F and can be used in boiling water on a limited basis. PC is unaffected by greases, oils, detergents, aliphatic hydrocarbons, most mineral acids, and the higher alcohols. It is attacked by chlorinated hydrocarbons, and most aromatic solvents, esters, and ketones. PC has white water transparency with a 90% light transmission.

APPLICATIONS

Fasteners, Washers, Spacers, Lenses, Housings.

POLYPROPYLENE (PP)

Polypropylene has a good combination of rigidity and toughness, high rigidity at elevated temperatures, can be steam sterilized, good abrasion resistance and low coefficient of friction, nonhydroscopic, excellent electrical properties, unique flex properties, good chemical resistance without stress cracking, one of the lowest densities, and high surface gloss. PP has the highest tensile strength of the olefins, high tensile modulus, and relatively low impact resistance. PP has good fatigue resistance, excellent abrasion resistance and very low coefficient of friction comparable to nylon. However, lubricating nylon surfaces reduces the friction much more than for polypropylene. Polypropylene has excellent chemical resistance to dilute acids, concentrated acids (except oxidizing acids) alkalis, alcohols, detergents, and water. PP resists aromatic hydrocarbons, chlorinated hydrocarbons, greases, and oils at room temperature but is attacked at about 140° F.

APPLICATIONS

Fasteners-Spacers-Washers-Insulators-Hinge Applications-Containers-Battery Cases-Pump Parts

IMPORTANT

While the descriptions, applications, data, and information contained in the above specifications are presented in good faith and believed to be accurate, it is provided for guidance only. Because many factors affect application and use we recommend that you make tests to determine the suitability of a product for your particular purpose prior to use.

PLASTIC MATERIALS PRINCIPAL PROPERTIES

SECTION
XX
INFORMATION

Nylon 46		Nylon 6/6 Flame Ret.		Nylatron GS	Acetal Copolymer	HDPE	Polycarbonate	Polypropylene
Dry	Moist	Dry	Moist					
14,400	9,400	11,600	6,500	13,500	8,800	2,470	10,300	4,700
435,000	145,000	520,000	290,000	110	70		220	165,000
30/25	280/250		10	15	60	700	150	9
				10,500	7,700		7	
460,000	145,000	250,000		460,000	375,000	146,000	350,000	210,000
1.8	7.5	1.5		0.7	1.3	2.3	16	0.6
				0.26				
				0.25	0.15			
320		435		210	316		275	220
		195			230		260	120
563		470		480	329	270	309	305
425							309	320
311		220			220			
1.18		1.16		1.16	1.41	0.954	1.2	0.905
3.7		2.6		0.9	0.22		0.15	0.3
R123	R107	M52		R119	M80	D62	R118	R95
94V2		94V0		Self Ext	94HB		94V2	
600		2000			500		420	425/550
3.8	5	3.6	6		3.7		2.93	
10 ¹⁶	10 ¹⁴	10 ¹⁵	10 ¹¹		10 ¹⁴		2X10 ¹⁷	

PLASTIC MATERIALS PRINCIPAL PROPERTIES

Property	ASTM Method	Units	Nylon 6/6		Nylon 6/6 Impact Modified		Nylon 6/6 33% Glassfilled	
			Dry	Moist	Dry	Moist	Dry	Moist
Mechanical								
Tensile Strength	D638	PSI	12,000	11,000	7,900		28,000	22,000
Tensile Impact Strength	D1822	FT LB/IN ²						
Tensile Modulus	D638	PSI	232,000		232,000			
Elongation	D638	%						
Break			40-60	300	150	170	4	5
Yield								
Shear Strength	D732	PSI	9,500	8,200	6,900		13,000	10,100
Flexural Modulus	D790	PSI	410,000	185,000	220,000	100,000	1,300,000	900,000
Impact Strength	D256	FT LB/IN	1	2.1	17	NO BRK	2.2	2.6
Thermal								
Coefficient of Friction								
Static			0.31					
Dynamic			0.17					
Deflection Temperature	D648	°F						
66PSI			470		340		495	
264 PSI			170		140		485	
Softening Point	D1525	°F						
Melting Point	D789	°F	500		500		505	
Peak Temperature		°F						
Continuous Use Temperature		°F	185					
Physical								
Specific Gravity	D792		1.14		1.07		1.38	
Water Absorption	D570	%	1.5		2.3		1	
Hardness	D785		M80	M61	M60	M50	M100	M82
Underwriters Lab. Rating	BUL 94		94V2		94HB		94HB	
Dielectric Strength	D149	V/MIL	600		2250	1300		400
Dielectric Constant	D150	1000 HZ	5.3		3.1	3.6	4	
Volume Resistivity	D257	OHM/CM	10 ¹⁴	10 ¹³	4X10 ¹⁴	10 ¹²	10 ¹⁴	
Electrical								

Important: While the descriptions, applications, data, and information contained in the above specifications are presented in good faith and believed to be accurate, it is provided for guidance only. Because many factors affect application and use we recommend that you make tests to determine the suitability of a product for particular purpose prior to use.

TOLERANCES AND QUALITY OF INJECTION MOLDED NYLON SCREWS

Micro Plastics' molded nylon components are accurately molded of Type 6/6 Nylon. They are tough, resistant to corrosion, light weight and good electrical insulators. Nylon components conform to irregular surfaces, provide vibration dampening, and offer an inexpensive alternative to more expensive metal parts. Molded threads approximate UNC/UNF 2A and 2B. Metric approximate 6g/6H.

Tolerances are generally held to Industrial Fasteners Institute Standards for inch and metric screws. However, it is often more sensible to try samples or small order quantities before changing from one product to another. Plastic molding has varying degrees of quality. It often involves small amounts of flash, knockout pin marks, gates, sinks, and other slight imperfections. Screws and bolts are gated on the threaded end. It is possible for the gate to leave an extra projection of up to .025"

Nylon screws have been available for many years commercially. They are either machined on a screw machine or injection molded. The machined parts are made from extruded nylon rod stock and can be held to relatively close tolerances during the machining process. Nylon, however, has the unfortunate property of absorbing moisture from its environment which causes significant changes in its dimensions. So even though parts may have been accurately machined, a moist atmosphere can cause fit problems. Conversely, parts that have been moisture conditioned can "lose" moisture causing dimensional problems. If the overall length of a screw grows, it obviously affects the threads per inch thus causing a tight fit. Changes in the moisture content can also have an effect on the outside diameter, pitch diameter and the root diameter.

Injection molded nylon screws also suffer from moisture problems but in addition, have inherent tooling problems. All molded nylon screws come from mold cavities parted along the length of the screw. These cavities have two halves that must be matched exactly to produce a perfect part. The cavity halves are doweled together with leader pins when the mold closes to provide the match required. Other locking devices are also employed to hold the halves of the mold in alignment. In the course of molding production quantities, these leader pins and locks suffer some wear. The mold base holding the cavities wears. The molding machine wears causing slight press platen misalignment. Small amounts of dirt on the mold can cause slight mismatch. From the time the tooling begins to run in production, the entire process begins to work against perfect alignment. Mold temperature changes from room temperature to production temperature causes the mismatch condition to worsen. At some point in time, the various factors affecting mismatch reach a condition that causes the molded screw to be unsatisfactory for the user. Then it is necessary to rework the mold to bring it up to its original condition. Since nylon is somewhat flexible, generally molded nylon screws are not held to as quite close tolerances as metal screws. A slight mismatch and minor flash at the parting line is not as serious as it would be in a metal part. End users who submit nylon screws to go-no go gages without trying the fastener in its actual functional application are generally causing unnecessary difficulties for themselves and their supplier. The fact is that because of the many areas of potential process variables, nylon screws made by injection molding are simply not measurable by the same methods as metal screws. They just are not capable of being manufactured to as close tolerances as metal screws.

The development of the tooling for nylon screws, plus the molded conditions, is a carefully kept secret. Tooling such as this is an evolutionary process. The quality of parts being manufactured today with today's tooling is obviously superior to those made in the beginning. Slight improvements have gradually been made over the years. Since we have production tooling for nearly 3,000 sizes, if we make tooling improvements it is not practical to go back and remake 3,000 molds each time we make an improvement. We do, however, rework and replace as we go along any obviously unsatisfactory tooling. This is a continual process with new sizes being added constantly and at the same time remaking tooling whenever the circumstances require it.

Occasionally, a few unacceptable parts may escape our quality control procedures. If you receive unsuitable parts, let us know immediately. We will do whatever we can to correct them.

All nylon screws are molded in a natural color resin. If you require black color, or some other identifying color (not a color match) these parts are made by dyeing the nylon screw with "RIT" dye in a water solution held at about 200 ° F which adds color but also moisture to the nylon. As stated previously, nylon screws change considerably with the loss or gain of moisture. Nylon screws, as they come from the molding machine contain about .5% moisture. After dyeing in "RIT" dye, the moisture content increases to about 3-4%. Low moisture nylon is more rigid than moisture conditioned material. Impact strength and toughness increases with moisture addition. Flexibility also increases with higher moisture content which causes difficulties for the user on occasion. If you need a solid molded color, a closer than normal tolerance, a special grade of nylon or other plastic material, we can furnish whatever variation or specialty using special molds and set up. This, of course, adds considerably to the cost. We are here to serve you, so tell us what you need.

TOLERANCES OF INJECTION MOLDED NYLON STANDARD COMPONENTS

**TOLERANCES ARE REFERENCE ONLY -
For exact tolerances see individual part
drawing at www.microplastics.com**

+/- .005 ON DIMENSIONS THRU .625
+/- .008 ON DIMENSIONS FROM .626 THRU 1.000
+/- .010 ON DIMENSIONS FROM 1.001 THRU 1.500
+/- .015 ON DIMENSIONS LARGER THAN 1.500
+/- .015 ON FRACTIONAL DIMENSIONS
+/- .13MM ON DIMENSIONS THRU 15.88MM
+/- .20MM ON DIMENSIONS FROM 15.89MM THRU 25.41MM
+/- .25MM ON DIMENSIONS FROM 25.42MM THRU 38.10MM
+/- .38MM ON DIMENSIONS LARGER THAN 38.10MM



MINIMUM ORDER \$100.00
MINIMUM LINE CHARGE \$20.00

SECTION
XX
INFORMATION

**PLEASE MARK ALL TELEPHONE ORDERS
"CONFIRMING" TO AVOID POSSIBLE DUPLICATION.**

General - 1% 10 net 30. FOB Flippin, Arkansas, No transportation allowed. Shipping method to be at seller's discretion unless buyer specifies routing. Shipments will not be insured unless requested by buyer. Buyer will bear cost of insurance and any other unusual transportation cost. Orders will be acknowledged with our standard terms of sale current at the time order is placed.

Prices - Quantity prices apply only to orders for parts which can be produced in one production run and are scheduled for release within a 60 day period from the first scheduled production run.

Prices - We reserve the right to increase prices when a careful review of our costs indicates a need for additional revenue.

Tooling - We will maintain tooling for a reasonable time in accordance with good industry practice. Molds that will not produce acceptable parts after reasonable maintenance will be subject to negotiation.

Tooling is not insured unless specifically requested. In those cases an additional charge will be made for insurance cost.

Delivery - Unless otherwise specifically provided in writing, hereunder shall be FOB point of shipment. In all cases, risk of loss or damage to goods in transit shall fall upon the purchaser, whose responsibility it shall be to file claims with the carrier.

Shipping dates are approximate and are based upon the prompt receipt of all necessary information. We shall not be liable for delay in delivery due to causes beyond our reasonable control.

Cancellation - Orders are not subject to cancellation, change, reduction in amount, or suspension of deliveries except with our consent and upon terms which protect us from loss.

Patents - The Purchaser shall hold us harmless against any expense or loss resulting from infringement of patents or trademarks arising from compliance with Purchaser's designs or specifications or instructions.

Quantity - All parts are accurately counted on sophisticated electronic scales compensated for slight weight variations due to minor mold cavity differentials. Custom part shipments are subject to a +/- 10% order quantity variation.

Returned Material Authorization - If parts are found to deviate beyond tolerances, mail samples back to us with your report, we will then, upon our findings issue a RMA number.

NO MATERIAL will be accepted for credit without a RMA. Unauthorized returns will be shipped back and re invoiced with a minimum handling charge of \$50.00 added.

Claims - Inspect all shipments within 30 days of receipt. Failure to advise us of defects on shipments within the 30-day period will constitute acceptance of the shipment.

Any purchase order with terms or clauses which are in conflict with the terms listed above, and/or any order with terms other than those listed herein is voidable by Micro Plastics, Inc. We reserve the right to discontinue items, change specifications or design at any time without notice and without incurring any obligations.

CAUTION: Some shipments are moisture packed. Do not open sealed package until use, reseal after opening.



ALPHABETICAL INDEX

SECTION
XXI
INFORMATION



www.aboveboardelectronics.com
1-800-453-1692

A AAWC PAGE 208	FLC PAGE 185	MMHTSP PAGE 281	RN PAGE 15	TCSP PAGE 238	02 A PAGE 38
ABC 175	FSTP-FTP 228, 229	MMP 284	RR 137	TI 224	02 B 37
AC 166	FW 61	MP 160-161,190-191	RS 111-122	TM 133	02 APC 37
ACC 186	FWRT 60	MP 193-197	RT (PBB) (A) 156	TMF 225	03 32,36
AF 192	G GRMF-GRMM 251	MP(SB) 186	RV-RVS-RVC 234	TMSP 239	03 FXM 34
ALIEN 253	GUTADHCLIP 248	MP(TLB) 187	RSSR 123-125	TN 52, 274	03 XM 35
AMR 137	H HC 242	MP(SBOD) 187	RSFP RSFK 163	TNA 52	09 T 31
APCC 50	HCFC 244	MP(ATB) 189	S SC 99	TPF 224	09 TEG 30
APF-APM 159	HDCC 179	MP(TB) 192	SCH 250, 252	TRM 225	09 V 31
APR-APT 159	HDEC 227	MPET 198	SCHCLIP 252	TSN 49	25 101
ASM 159	HDH 251	MPH 225	SCHINSTL 251	TSP 126-127	29 F 16
ASO 18, 258, 285	HDN-HFN 54	MPS 161	SCM 278	TAPM 219	29 M(R) 17
ASR-AST 159	HJUN-HJN 55	MPT 198	SCN 53	U UNFCPN 50	29 R 17
AWC 176-177,181,185	HN 56, 273	MRF-MRM 133, 136	SCOVER 246	UNFLUG 50	29 RN 15
AWC-TAB 178,186	HNDIN 272	MSP 233	SCP 179	USP 163	29 TL 18
AWCF AWCF-A 177	HNPC-HNS 56	MTP 232	SCVR 246	V VP (BM) 164	29 W 16
B BR 162	HSC 243	MWCA 181	SEAPM-SEWC 183	W W 16, 62-79	29 WN 15
C CAWC-(TAB),(VHB) 178	HSP 128	MWC 184	SFW 60	WA 169	31 48
CC 172,173	HTSP 129	MWHA 283	SGC 142	WA 169	32 33
CDC 184	I INDWIREKIT 248	MXT 283	SGN 139-142	WC 179	32 W 33
CGS-WS 235	INSTHOOK 252	N N 200	SHOK, SHOOK 252	WCPM 185	33 A 39
CINCH 143	K KY 165	NCC 209	SJN 55	WFHN 274	34 29
CM 224	KYP 235	NT, NTA 212-214	SKCDHK-RET 249	WHA-WHB 182	36 MF 102, 280
CM 224	L LAD 230	NTT 214	SL 222-223	WN 15,58,275	38 SD 41
CN 51,273	LB 199	NM 203,208,219	SLN 57	WNA-WNC 58	38 TR 40, 272
CS 122	LCN 51, 273	NPT 47	SNC 149	WP 170	38 TRPVC 40
CT 212	LCSP 238	NPTH 47,253	SNHK 249	WSP 163	39 A 19
CTDZ 211	LEDSP 188	P P 200	SP 103-109	WTR 174	39 F 19
CW 100	LEDH 188	PC 170	SPC 180	X XT 158	39 R 19
CNSP 51	LEDSRM 189	PHCET-PHCT 244	SPG 143	XTS 156,157,158	39 W 19
D DBEZ 204	LF-LGWH 171	PIF 146-148	SPNP-SPNN 53	Z ZERO 210	40 32,38,138,250
DECOWN 59	LLP 231	PJN 55	SPRINGW 98	MISC 01 ABTS 41	40 144-145,149
DGHC 245	LMSP 239	PMF 153	SPRT 130-131	01 B 20	40 167-168
DLP 237	LMT 232	PMPET-PMPT (JAW) 198	SPW 202	01 CD 46	50M BH 268
DLWN 59,275	LN 57,273	POST, (PC) (NT) 134-135	SR 150,151	01 EYEB 47	50M D 259
DM 133	LP 36,199	PP (BG) (BM) 164	SS 131	01 F 21	50M F 267
DMS-SP 236	LPN-LPNS 36	PP 135	SSP 163	01 FHWS 49	50M G 266
DP 188	LSP 163,237	PPM 282	STF-STM 132	01 G 44	50M H 269
DPC 180	LTP 231	PPRT 154	STMB 132	01 H 23	50M I 268
DRC 221	LTS 110	PR 152-153	STS 226	01 LP 36	50M J 261
DSC 181	LWC 201	PRT 154	SW 100	01 P 24	50M K 260
DWN 275	M M TR 272	PS 227	SWRC 184	01 P (PC) 42	50M L 263
E EXTPOLE 248	M 17, 277	PSS 153	SWS 80-97	01 W (PC) 42	50M M 262
EXPINDWIRE KIT 248	MDIN 277	PTC 241	SRRW 98	01 F (PC) 43	50M N 265
EZ 204	ME 279	PTI 240	SC (HW,H,K,R,P) 155	01 X (PC) 43	50M P 264
EZAB, EZABS(TAB) 205	MF 102, 280	Q QB 169	SCOVERM 246	01 R 25	50M R - 50M S 270
EZF 203,206	MG 200	QCC 174	SOLC 201	01 S 26	50M T 271
EZSFA 206	MHSP 281	R R 17	SOWC 171	01 T 27	
EZLB 207	MLSW 276	RC 175	SL ADCLIP 223	01 WF 28	
EZS 205,207	MLMTP 284	RCFB 183	SLA 215-218,220	01 WTS 49	
F F 16	MLAD 227	RCFB-C 182	SLADCLIP 223	01 X 22	
FCC 175	MLSP 232	RCPM 175	SWIFTKEY (HD) 247		
FPCM 215	MLLP 228	RIV 230	TA 215-218,220		
			TAHL 219		
			TC 137		

plugs

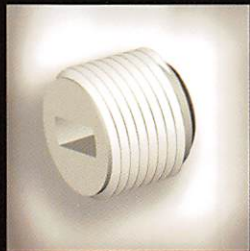

spacers

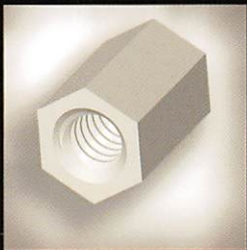

rivets

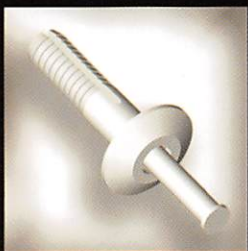

bushings



nuts

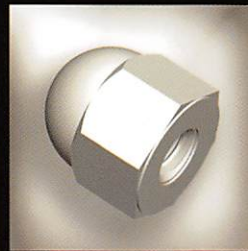

DISTRIBUTORS
IN 37 COUNTRIES



www.aboveboardelectronics.com
1-800-453-1692



micro plastics intl.

premier global manufacturer of plastic fasteners

Micro Plastics International.co.uk • Unit 2 Henley Ind. Park • Henley Road • Coventry, CV2 1st, UK • 44 (0) 2476-614320

Micro Plastics International^{MR} • Carretera a Huinala #510 Fracc. Ind. • San Andres CP 66640 Apodaca N.L. • (52) 81 8000 3760

CAT #41

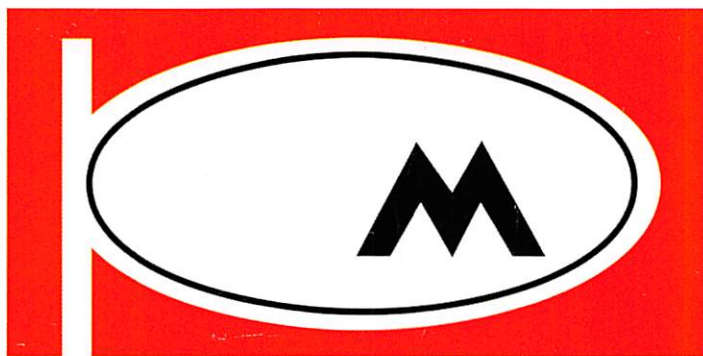

micro plastics,® inc.