



Heyco-Flex™ Metallic Liquid Tight Conduit Fittings

For use with Nonmetallic Heyco-Flex™ I Electrical Conduit

Straight-Thru, NPT Hubs

FITS CONDUIT/TUBING TRADE SIZE	PART NO.	DESCRIPTION	PART DIMENSIONS									
			BODY AND SEALING UNIT									
			A Clearance Hole		B Max. O.A. Length		C Thread Length		D Nut Thk.		E Wrenching Flat Size	
in.	mm.	in.	mm.	in.	mm.	in.	mm.	in.	mm.			
1/2	9794	HFC-Z 1/2	.890	22,6	1.270	32,3	.486	12,3	.161	4,1	1.185	30,1
1	9793	HFC-Z 1	1.375	34,9	1.670	42,4	.580	14,7	.161	4,1	1.690	42,9

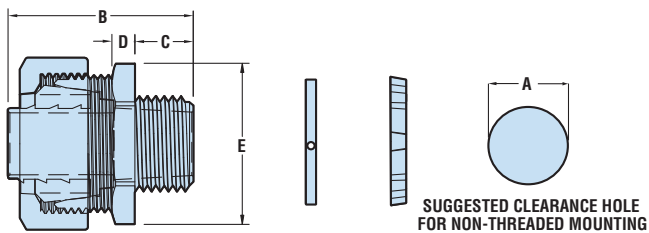

90° Sweep, NPT Hubs

FITS CONDUIT/TUBING TRADE SIZE	PART NO.	DESCRIPTION	PART DIMENSIONS											
			BODY AND SEALING UNIT											
			A Clearance Hole		B Max. O.A. Length		C Max. O.A. Height		D Thread Length		E Nut Thk.		F Wrenching Flat Size	
in.	mm.	in.	mm.	in.	mm.	in.	mm.	in.	mm.	in.	mm.			
1/2	9796	HFC-Z 1/2-90	.890	22,6	2.346	59,6	2.118	53,8	.515	13,1	.105	2,9	1.135	28,8

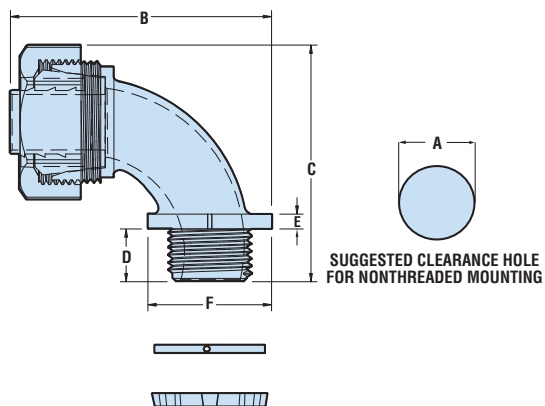

- Cost effective die-cast zinc construction provides durability and resists rough environments.
- Liquid Tight when used with Heyco-Flex™ I Liquid Tight Conduit. See Page 2-1.
- Provide smooth connection, no sharp edges to strip wire.
- Suitable for outside, inside, and industrial uses including transformer connections, air conditioning, and heating.
- Suitable for use in both wet and dry location.
- Fit the most common sizes of nonmetallic liquid tight conduit.
- If using a tapped hole, Teflon® tape is needed on the threads of the connector, for all other applications an O-ring and Locknut are needed to attain liquid tight.
- Supplied with locknut and plastic sealing ring.



Material
Certifications

Die cast zinc
 Listed under UL File E103541

Quick
Specs