

Standoffs For Thin Sheet Material

Series CFT, CFTS, CFTA

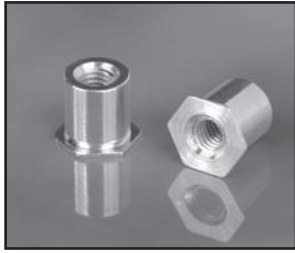

CFT standoffs allow flush-head installation in a material thickness of .025 in. (.63mm) or more.

Series	Material	Finish
CFT	Non-Heat-treated Carbon Steel	Zinc* Clear
CFTS	300 Series Stainless Steel	Passivated ASTM A967
CFTA	7075-T6 Aluminum	None

*See Finish Spec. on Page 6.

Thread: Internal 2B, ANSI B1.1.

Use In: CFT – Materials with HR of B-60 or less.

CFTS – Materials with HR of B-70 or less.

CFTA – Materials with HR of B-50 or less.

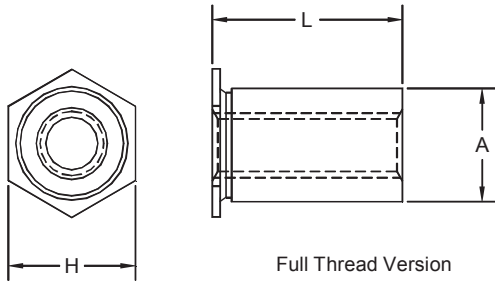

Full Thread Version

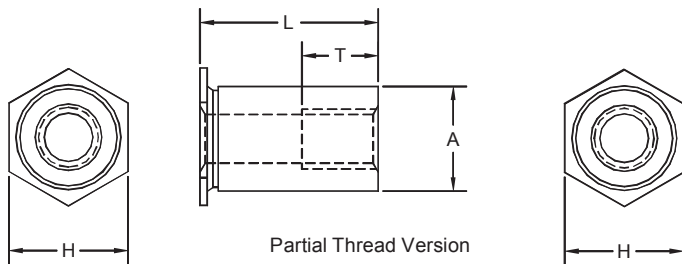

Partial Thread Version

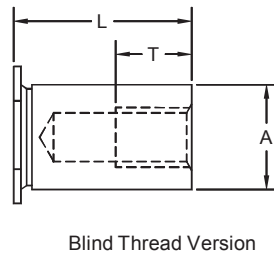

Blind Thread Version

Part Number Structure:

CFT 440-.090

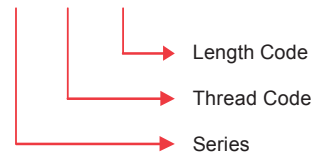

Dimensions & Specifications

Thread Size	Part Number	L Length ±.003 in.											+0.003 -0.000	A +0.000 -0.005	H Nom.	T Min.	Min.	Min.			
		.090	.125	.187	.250	.312	.375	.437	.500	.562	.625	.687							.750		
#2-56	CFT 256	-.090	-.125	-.187	-.250	-.312	-.375	-.437	-.500	-.562	-.625	-.687	-.750	.166	.165	.187	.200	.23	.025		
	CFTS 256	-.090	-.125	-.187	-.250	-.312	-.375	-.437	-.500	-.562	-.625	-.687	-.750								
	CFTA 256	-.090	-.125	-.187	-.250	-.312	-.375	-.437	-.500	-.562	-.625	-.687	-.750								
	CFT 6256	-.090	-.125	-.187	-.250	-.312	-.375	-.437	-.500	-.562	-.625	-.687	-.750				.213	.212	.250	.27	.025
	CFTS 6256	-.090	-.125	-.187	-.250	-.312	-.375	-.437	-.500	-.562	-.625	-.687	-.750								
	CFTA 6256	-.090	-.125	-.187	-.250	-.312	-.375	-.437	-.500	-.562	-.625	-.687	-.750								
#4-40	CFT 440	-.090	-.125	-.187	-.250	-.312	-.375	-.437	-.500	-.562	-.625	-.687	-.750	.166	.165	.187	.220	.23	.025		
	CFTS 440	-.090	-.125	-.187	-.250	-.312	-.375	-.437	-.500	-.562	-.625	-.687	-.750								
	CFTA 440	-.090	-.125	-.187	-.250	-.312	-.375	-.437	-.500	-.562	-.625	-.687	-.750								
	CFT 6440	-.090	-.125	-.187	-.250	-.312	-.375	-.437	-.500	-.562	-.625	-.687	-.750				.213	.212	.250	.27	.025
	CFTS 6440	-.090	-.125	-.187	-.250	-.312	-.375	-.437	-.500	-.562	-.625	-.687	-.750								
	CFTA 6440	-.090	-.125	-.187	-.250	-.312	-.375	-.437	-.500	-.562	-.625	-.687	-.750								
#6-32	CFT 632		-.125	-.187	-.250	-.312	-.375	-.437	-.500	-.562	-.625	-.687	-.750	.213	.212	.250	.270	.27	.025		
	CFTS 632		-.125	-.187	-.250	-.312	-.375	-.437	-.500	-.562	-.625	-.687	-.750								
	CFTA 632		-.125	-.187	-.250	-.312	-.375	-.437	-.500	-.562	-.625	-.687	-.750								
Version		Full Thread				Partial Thread			Blind Thread				Note: Items may be subject to minimum order.								





Standoffs For Thin Sheet Material

Series CFT, CFTS & CFTA



Continued from previous page.

CFT standoffs allow flush-head installation in a material thickness of .025 in. (.63mm) or more.

Series	Material	Finish
CFT	Non-Heat-treated Carbon Steel	Zinc* Clear
CFTS	300 Series Stainless Steel	Passivated ASTM A967
CFTA	7075-T6 Aluminum	None

*See Finish Spec. on Page 6.

Thread: Internal 6H, ANSI/ASME B1.13M.
 Use In: CFT – Materials with HR of B-60 or less.
 CFTS – Materials with HR of B-70 or less.
 CFTA – Materials with HR of B-50 or less.

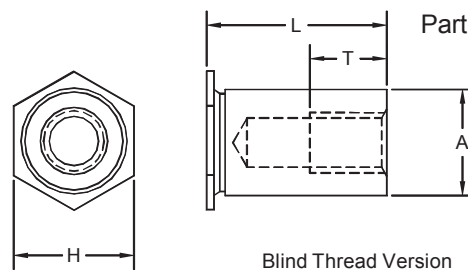
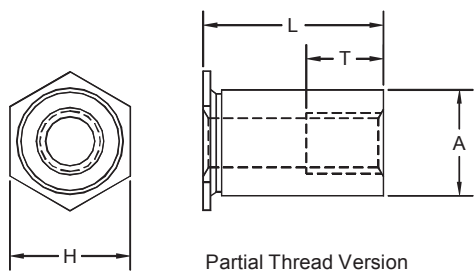
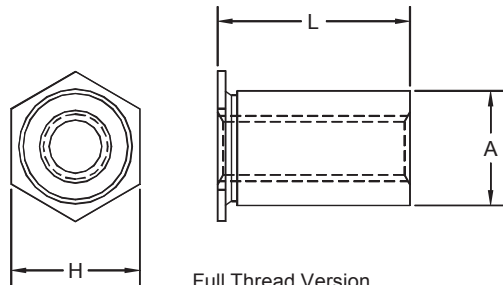

Part Number Structure:

CFT M2.5-200



Dimensions & Specifications

METRIC (mm)	Thread Size	Part Number	L Length ±.08 mm											+08 -00	A +00 -13	H Nom.	T Min.	Min.	Min.
			2.00	3.00	4.00	6.00	8.00	10.00	12.00	14.00	16.00	18.00	19.00						
M2.5x0.45	CFT	M2.5	-200	-300	-400	-600	-800	-1000	-1200	-1400	-1600	-1800	-1900	4.22	4.2	4.8	5.2	5.8	.63
	CFTS	M2.5	-200	-300	-400	-600	-800	-1000	-1200	-1400	-1600	-1800	-1900						
	CFTA	M2.5	-200	-300	-400	-600	-800	-1000	-1200	-1400	-1600	-1800	-1900	5.41	5.39	6.4	7.1	.63	
	CFT	6M2.5	-200	-300	-400	-600	-800	-1000	-1200	-1400	-1600	-1800	-1900						
	CFTS	6M2.5	-200	-300	-400	-600	-800	-1000	-1200	-1400	-1600	-1800	-1900						
	CFTA	6M2.5	-200	-300	-400	-600	-800	-1000	-1200	-1400	-1600	-1800	-1900						
M3x0.5	CFT	M3	-200	-300	-400	-600	-800	-1000	-1200	-1400	-1600	-1800	-1900	4.22	4.2	4.8	6.2	5.8	.63
	CFTS	M3	-200	-300	-400	-600	-800	-1000	-1200	-1400	-1600	-1800	-1900						
	CFTA	M3	-200	-300	-400	-600	-800	-1000	-1200	-1400	-1600	-1800	-1900	5.41	5.39	6.4	7.1	.63	
	CFT	6M3	-200	-300	-400	-600	-800	-1000	-1200	-1400	-1600	-1800	-1900						
	CFTS	6M3	-200	-300	-400	-600	-800	-1000	-1200	-1400	-1600	-1800	-1900						
	CFTA	6M3	-200	-300	-400	-600	-800	-1000	-1200	-1400	-1600	-1800	-1900						
M3.5x0.6	CFT	M3.5		-300	-400	-600	-800	-1000	-1200	-1400	-1600	-1800	-1900	5.41	5.39	6.4	7.0	7.1	.63
	CFTS	M3.5		-300	-400	-600	-800	-1000	-1200	-1400	-1600	-1800	-1900						
	CFTA	M3.5		-300	-400	-600	-800	-1000	-1200	-1400	-1600	-1800	-1900						
Version			Full Thread				Partial Thread		Blind Thread					Note: Items may be subject to minimum order.					



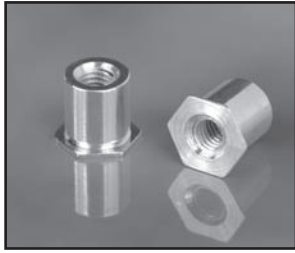

Standoffs For Thin Sheet Material

Series CFT, CFTS, CFTA



Continued from previous page.

Installation & Performance Data

A Dim.	Series	Sheet Material											
		.025 in. (.64mm) 5052-H-34 Aluminium						.025 in. (.64mm) Cold-rolled Steel					
		Installation		Pushout		Torque-out		Installation		Pushout		Torque-out	
lbs.	kN	lbs.	N	in.-lbs.	N•m	lbs.	kN	lbs.	N	in.-lbs.	N•m		
.165 in. (4.19mm)	CFT CFTS CFTA	1500	6.7	68	302	5	.56	2000	8.9	98	435	8	.90
		-	-	-	-	-	-	-	-	-	-	-	-
.212 in. (5.38 mm)	CFT CFTS CFTA	1800	8	88	391	10	1.13	2500	11.1	148	658	14	1.6
		-	-	-	-	-	-	-	-	-	-	-	-

The installation and performance data listed are nominal when all specifications are adhered to. Changes in sheet hardness and mounting hole tolerance will affect performance. Therefore, we recommend testing the product in your application to determine actual results. Samples are available upon request.

Installation

1. Prepare the required size hole in the base material by punching or drilling. Do not deburr hole.
2. Place standoff through hole in material and into installation anvil and squeeze into place using a shop press with flat punch.
3. Apply a sufficient force to seat the hex head flush into the base material.
4. Use chamfered anvil shown for sheet thickness of .025 to .032 in. (.63 to .81 mm) for sheets over .032 (.81 mm) The special anvil is not required.

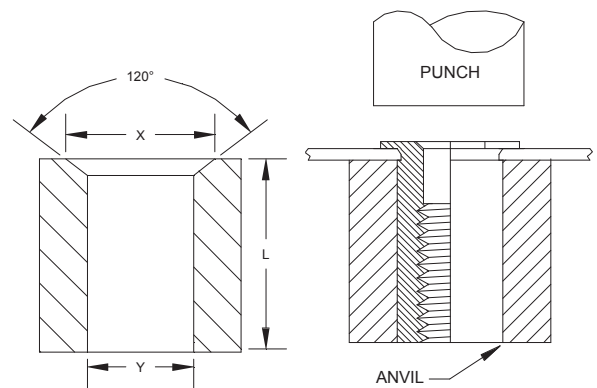

Standoff A Dimension	Anvil Dimensions			
	Y		X	
	Inches	mm	Inches	mm
.165 in./4.19mm	.167 - .170	4.24 - 4.32	.187 - .194	4.75 - 4.93
.212 in./5.38mm	.213 - .216	5.41 - 5.49	.250 - .257	6.35 - 6.53

