



# Self-Clinching Slide-Top Standoffs

## Series CFSKC



CFSKC slide-top standoffs are designed for a PC board or panel to be quickly attached and removed with a simple sliding motion. The slide-top standoffs provide advantages for reducing servicing time and eliminate the problems associated with loose hardware. Several slide-top standoffs can be used in conjunction with a Captive threaded standoff to lock the board in place.

Series	Material	Finish
CFSKC	300 Series Stainless Steel	Passivated ASTM A967

Use in: Materials HRB-70 or less.

Part Number Structure:

CFSKC 6060-6

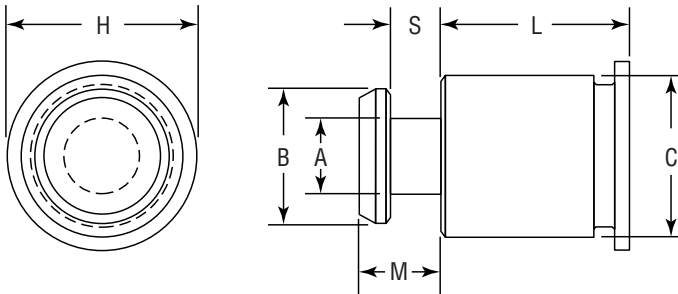

### Dimensions & Specifications

INCH (in.)	Series	Body/ Hole Code	L Length ±.005 in. Length Code is in 32nds of an Inch												A ±.003	B ±.003	C Max.	S ±.003	M Max.	H Nom.	Anvil Hole Dia. +.003 -.000
			.188	.250	.312	.375	.437	.500	.562	.625	.750	.875	1.00								
			-6	-8	-10	-12	-14	-16	-18	-20	-24	-28	-32								
CFSKC	6060		.188	.250	.312	.375	.437	.500	.562	.625	.750	.875	1.00	±.003	±.003	Max.	±.003	Max.	Nom.	+.003 -.000	
																				.216	

### Dimensions & Specifications

METRIC (mm)	Series	Body/ Hole Code	L Length ±.13mm.												A ±.08	B ±.08	C Max.	S ±.08	M Max.	H Nom.	Anvil Hole Dia. +.08 -.00
			6	8	10	12	14	16	18	20	22	25									
			6	8	10	12	14	16	18	20†	22†	25†									
CFSKC	61.5		6	8	10	12	14	16	18	20†	22†	25†	2.51	4.5	5.39	1.73	2.75	6.35	5.5		

† Not stocked, available on special order.

### Installation & Performance Data

INCH (in.)	Body Size/ Hole Code	.060 in. (1.52mm) 5052-H34 Aluminum		.060 in. (1.52mm) Cold-rolled Steel	
		Installation (lbs.)	Pushout (lbs.)	Installation (lbs.)	Pushout (lbs.)
	6060	1600	250	3200	600
METRIC (mm)	61.5	(kN)	(N)	(kN)	(N)
		7.1	1100	14.2	2600





# Self-Clinching Slide-Top Standoffs

## Series CFSKC

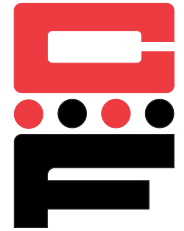

Continued from previous page.

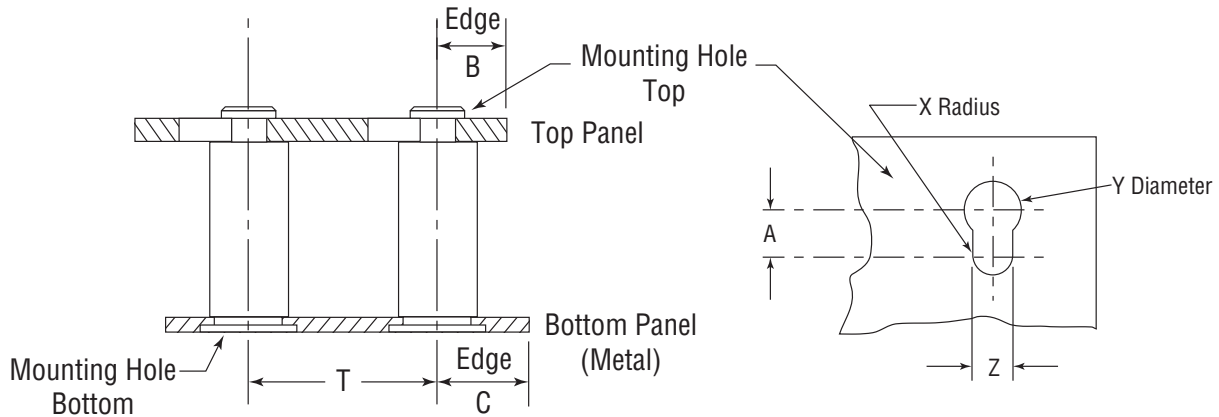

### Installation & Performance Data

INCH (in.)	Bottom Panel					Top Panel						
	Series	Bottom Mounting Hole +.003 -.000	Min.	C Min.	Location Tolerance T Max.	Top Mounting Hole				Material	Thickness Range	B Min.
						X Nom.	Y ±.003	Z ±.003	A Min.			
	CFSKC	.213	.040	.260	±.005	.059	.197	.118	.148	PC Board or Metal	.057 - .064	.160

### Installation & Performance Data

METRIC (mm)	Bottom Panel					Top Panel						
	Series	Bottom Mounting Hole +.08 -.00	Min.	C Min.	Location Tolerance T Max.	Top Mounting Hole				Material	Thickness Range	B Min.
						X Nom.	Y ±.08	Z ±.08	A Min.			
	CFSKC	5.41	1.02	6.6	±.13	1.5	5.0	3.0	3.75	PC Board or Metal	1.45 - 1.62	4.1

