

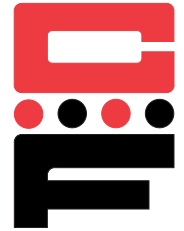

Self-Clinching Standoffs

Series CF4-SO

(400 Series Standoffs)



CF4-SO Standoffs are designed to be pressed into round holes in stainless steel material as thin as .040 (1mm). The through-hole versions are available in a choice of inch and metric sizes.

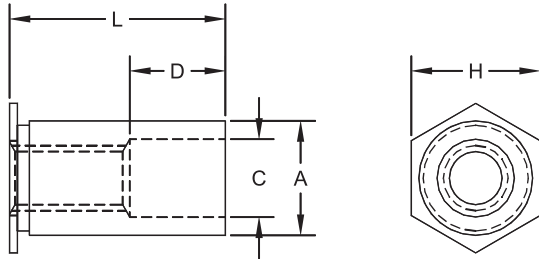

Through Threads

Series	Material	Finish
CF4-SO	400 Series Stainless Steel	Passivated ASTM A967

Thread: Internal 2B, ANSI B1.1 (6H, ANSI/ASME B1.13M).
Use in: Materials with Rockwell Hardness of B88 or less.

Part Number Structure:

CF4-SO 6440-4

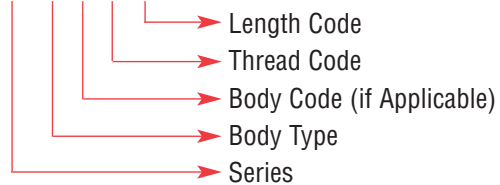

All Measurements In Inches.

Dimensions & Specifications

Thread Size	Part Number	L Length +.002 -.005 in.															A Dim. +.000 -.005	H Hex Dim. (Nom.)	C Counter-bore ±.005	Min.	Min.		
		.125	.187	.250	.312	.375	.437	.500	.562	.625	.687	.750	.812	.875	.937	1.00						1.062	
#4-40	CF4-SO 440	-4	-6	-8	-10	-12	-14	-16	-18	-20	-22	-24					.166	.165	.187	.125	.23	.040	
	CF4-SO 6440	-4	-6	-8	-10	-12	-14	-16	-18	-20	-22	-24					.213	.212	.250	.125	.27	.040	
#6-32	CF4-SO 632	-4	-6	-8	-10	-12	-14	-16	-18	-20	-22	-24	-26	-28	-30	-32	-34	.213	.212	.250	.156	.27	.040
	CF4-SO 8632	-4	-6	-8	-10	-12	-14	-16	-18	-20	-22	-24	-26	-28	-30	-32	-34	.281	.280	.312	.156	.31	.050
#8-32	CF4-SO 832	-4	-6	-8	-10	-12	-14	-16	-18	-20	-22	-24	-26	-28	-30	-32	-34	.281	.280	.312	.188	.31	.050
#10-32	CF4-SO 1032	-4	-6	-8	-10	-12	-14	-16	-18	-20	-22	-24	-26	-28	-30	-32	-34	.281	.280	.312	.203	.31	.050
D ±.010		None			.187			.312			.437												

All Measurements In Millimeters.

Thread Size	Part Number	L Length +.05 -.13 mm												A Dim. +.00 -.13	H Hex Dim. (Nom.)	C Counter-bore ±.13	Min.	Min.					
		3	4	6	8	10	12	14	16	18	20	22	25										
M3x0.5	CF4-SO M3	-3	-4	-6	-8	-10	-12	-14	-16	-18				4.22	4.2	4.8	3.2	6	1.02				
	CF4-SO 3.5M3	-3	-4	-6	-8	-10	-12	-14	-16	-18				5.41	5.39	6.4	3.2	6.8	1.02				
M3.5x0.6	CF4-SO M3.5	-3	-4	-6	-8	-10	-12	-14	-16	-18	-20	-22	-25	5.41	5.39	6.4	3.9	6.8	1.02				
M4x0.7	CF4-SO M4	-3	-4	-6	-8	-10	-12	-14	-16	-18	-20	-22	-25	7.14	7.12	7.9	4.8	8	1.27				
M5x0.8	CF4-SO M5	-3	-4	-6	-8	-10	-12	-14	-16	-18	-20	-22	-25	7.14	7.12	7.9	5.35	8	1.27				
D ±.25		None			4.0			8.0			11.0												





Self-Clinching Standoffs

Series CF4-BSO

(400 Series Blind Standoffs)



Continued from previous page.

CF4-BSO Standoffs are designed to be pressed into round holes in stainless steel material as thin as .040 (1mm). The blind-hole versions are available in a choice of inch and metric sizes.

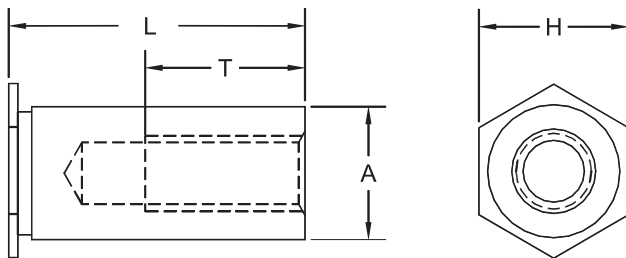

Blind Threads

Series	Material	Finish
CF4-BSO	400 Series Stainless Steel	Passivated ASTM A967

Thread: Internal 2B, ANSI B1.1 (6H, ANSI/ASME B1.13M).

Use in: Materials with Rockwell Hardness of B88 or less.

Part Number Structure:

CF4-BSO 6440-10

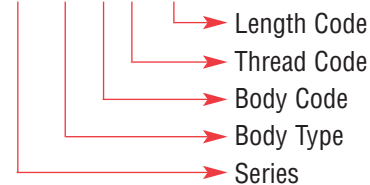

All Measurements In Inches.

Dimensions & Specifications

Thread Size	Part Number	L Length +.002 -.005 in.													A Dim. +.000 -.005	H Hex Dim. (Nom.)	Min.	Min.	
		.312	.375	.437	.500	.562	.625	.687	.750	.812	.875	.937	1.00	1.062					
#4-40	CF4-BSO 440	-10	-12	-14	-16	-18	-20	-22	-24	-26	-28	-30	-32	-34	.166	.165	.187	.23	.040
	CF4-BSO 6440	-10	-12	-14	-16	-18	-20	-22	-24	-26	-28	-30	-32	-34	.213	.212	.250	.27	.040
#6-32	CF4-BSO 632	-10	-12	-14	-16	-18	-20	-22	-24	-26	-28	-30	-32	-34	.213	.212	.250	.27	.040
	CF4-BSO 8632	-10	-12	-14	-16	-18	-20	-22	-24	-26	-28	-30	-32	-34	.281	.280	.312	.31	.050
#8-32	CF4-BSO 832	-10	-12	-14	-16	-18	-20	-22	-24	-26	-28	-30	-32	-34	.281	.280	.312	.31	.050
#10-32	CF4-BSO 1032	-10	-12	-14	-16	-18	-20	-22	-24	-26	-28	-30	-32	-34	.281	.280	.312	.31	.050
T Dim. Min.		.156		.187		.250			.375										

All Measurements In Millimeters.

Thread Size	Part Number	L Length +.05 -.13 mm										A Dim. +.00 -.13	H Hex Dim. (Nom.)	Min.	Min.	
		6	8	10	12	14	16	18	20	22	25					
M3x0.5	CF4-BSO M3	-6	-8	-10	12	-14	-16	-18	-20	-22	-25	4.22	4.2	4.8	6	1
	CF4-BSO 3.5M3	-6	-8	-10	12	-14	-16	-18	-20	-22	-25	5.41	5.39	6.4	6.8	1
M3.5x0.6	CF4-BSO M3.5	-6	-8	-10	12	-14	-16	-18	-20	-22	-25	5.41	5.39	6.4	6.8	1
M4x0.7	CF4-BSO M4	-6	-8	-10	12	-14	-16	-18	-20	-22	-25	7.14	7.12	7.9	8	1.27
M5x0.8	CF4-BSO M5	-6	-8	-10	12	-14	-16	-18	-20	-22	-25	7.14	7.12	7.9	8	1.27
T Dim. Min.		3.2	4.0		5.0	6.5			9.5							





Continued from previous page.

Self-Clinching Standoffs

Series CF4-SO, CF4-BSO

(400 Series Standoffs)

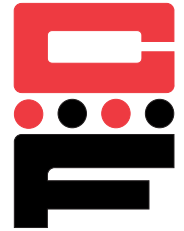

Dimensions & Specifications

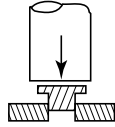
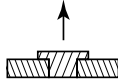
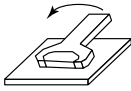
Sheet Material: .050 in. 300 Series Stainless Steel						
INCH (in.)						
	Thread Code	Installation Force (lbs.)	Pushout (lbs.)	Torque-out (in.-lbs.)	Pull Through (lbs.)	Rec. Tightening Torque Max. (in.-lbs.)
	440	5500	336	17	600	4.75
	6440	9500	647	30	680	4.75
	632	9500	647	30	680	8.75
	8632	10500	900	71	1392	8.75
	832	10500	900	71	1517	18
1032	10500	900	71	1368	32	

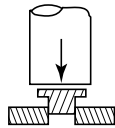
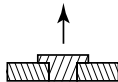
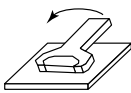
Sheet Material: 1.3mm 300 Series Stainless Steel						
METRIC (mm)						
	Thread Code	Installation Force (kN)	Pushout (N)	Torque-out (N•m)	Pull Through (N)	Rec. Tightening Torque Max. (N•m)
	M3	24.5	1493	2.36	2650	.55
	3.5 M3	42.3	2877	3.06	3025	.55
	M3.5	42.3	2877	3.06	3025	.91
	M4	46.7	4003	8.89	6458	2
	M5	46.7	4003	8.89	6226	3.6

RECOMMENDED INSTALLATION PROCEDURE

1. Insert Standoff through hole in sheet into anvil.
2. Apply sufficient squeezing force between parallel surfaces of punch and anvil to embed hex head flush in sheet. Avoid excessive pressure.

