

Magna-Tite®

All-aluminum fastener ideal for thin or low-strength materials.

The Huck Magna-Tite® is a specialized aluminum structural rivet fastener well-suited for use within oversized holes and repair applications. Its wide, blind-side bulb makes it ideal for installation in thin or low-strength materials such as aluminum, fiberglass, and plastic. Unlike other bulbing blind fasteners, the Huck Magna-Tite has a unique embedded sealant applied between the pin and sleeve.

Available Sizes:

3/16", 1/4"

Materials:

Aluminum

Headstyles:

Protruding, Shavable, Low Profile, 100° Oval Flush



Secure, Fast Installation

1. Large blind-side footprint for installation in thin or compressible materials where controlled strength is required.
2. Unique embedded sealant applied between the pin and sleeve.

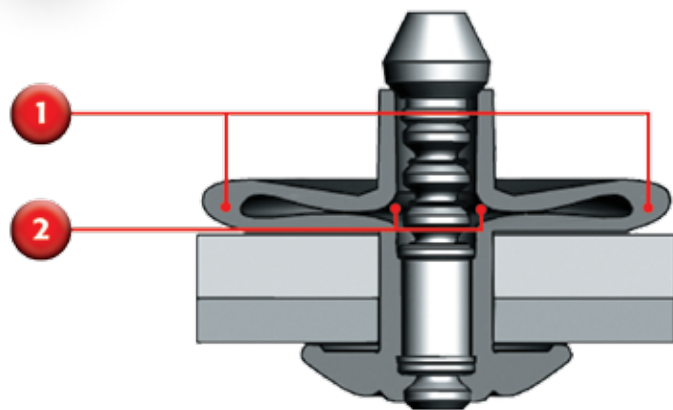

Magna-Tite Data & Dimensions

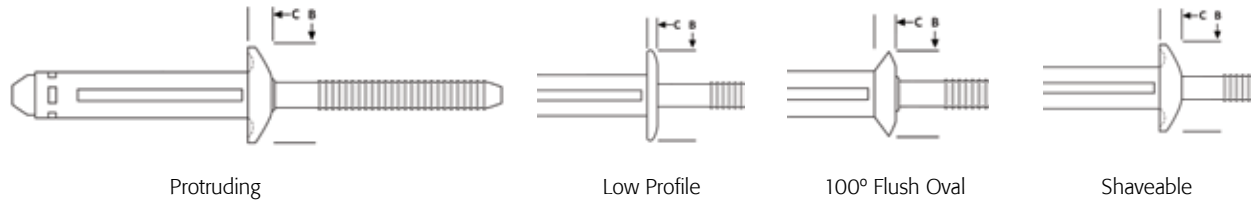

Aluminum Rivet/Aluminum Mandrel

Diameter	Part No.	Sealant	Grip Range	Max Hole Size	[B] Head Dia (max)	[C] Head Height (max)	Typical Shear (lbs)	Typical Tensile (lbs)
Protruding Head								
3/16"	MTP-B6-5S	PVC	.050-.312	.221	.453	.117	630	450
	MTP-B6-6		.100-.375	.221	.453	.117	630	450
	MTP-B6-6S	PVC	.100-.375	.221	.453	.117	630	450
	MTP-B6-8S	PVC	.250-.500	.221	.453	.117	630	450
	MTP-B6-10S	PVC	.375-.625	.221	.453	.117	630	450
	MTP-B6-12S	PVC	.500-.750	.221	.453	.117	630	450
1/4"	MTP-B8-4		.040-.250	.263	.530	.120	1100	650
	MTP-B8-4S	PVC	.040-.250	.263	.530	.120	1100	650
	MTP-B8-6		.125-.375	.263	.530	.120	1100	650
	MTP-B8-6S	PVC	.125-.375	.263	.530	.120	1100	650
	MTP-B8-8S	PVC	.250-.500	.263	.530	.120	1100	650
	MTP-B8-10S	PVC	.375-.625	.263	.530	.120	1100	650
	MTP-B8-12S	PVC	.500-.750	.263	.530	.120	1100	650
Oval Head								
3/16"	MTV-B6-5S	PVC	.070-.312	.221	.355	.117	630	450
	MTV-B6-7S	PVC	.160-.410	.221	.355	.117	630	450
	MTV-B6-8S	PVC	.250-.500	.221	.355	.117	630	450
	MTV-B6-10S	PVC	.375-.625	.221	.355	.117	630	450
	MTV-B6-12S	PVC	.500-.750	.221	.355	.117	630	450
Low Profile Head								
3/16"	MTLP-B6-4		.050-.250	.221	.453	.052	630*	450
	MTLP-B6-8		.187-.500	.221	.453	.052	630*	450
	MTLP-B6-12		.375-.750	.221	.453	.052	630*	450
	MTLP-B6-12X		.050-.750	.221	.453	.052	630*	450
Shaveable Head								
3/16"	MTS-B6-8		.050-.500	.221	.453	.117	630	450
	MTS-B6-8S	PVC	.050-.500	.221	.453	.117	630	450
	MTS-B6-12S	PVC	.050-.750	.221	.453	.117	630	450

* In Minimum Grip. 350 lb. shear strength over minimum grip. NOTE: Part number listings reflect typical stock. Items not listed require a minimum order.

Installation Tooling

Diameter	Installation Tool	Nose Assembly	Type
3/16"	2015	125280 (Insert)	Pneudraulic
	2024	99-3310F/P 99-3311F/P	Pneudraulic
	2480	99-3310F/P 99-3311F/P	Hydraulic
1/4"	2015	125280 (Insert)	Pneudraulic
	2024	99-3312F/P	Pneudraulic
	2480	99-3312F/P	Hydraulic

