

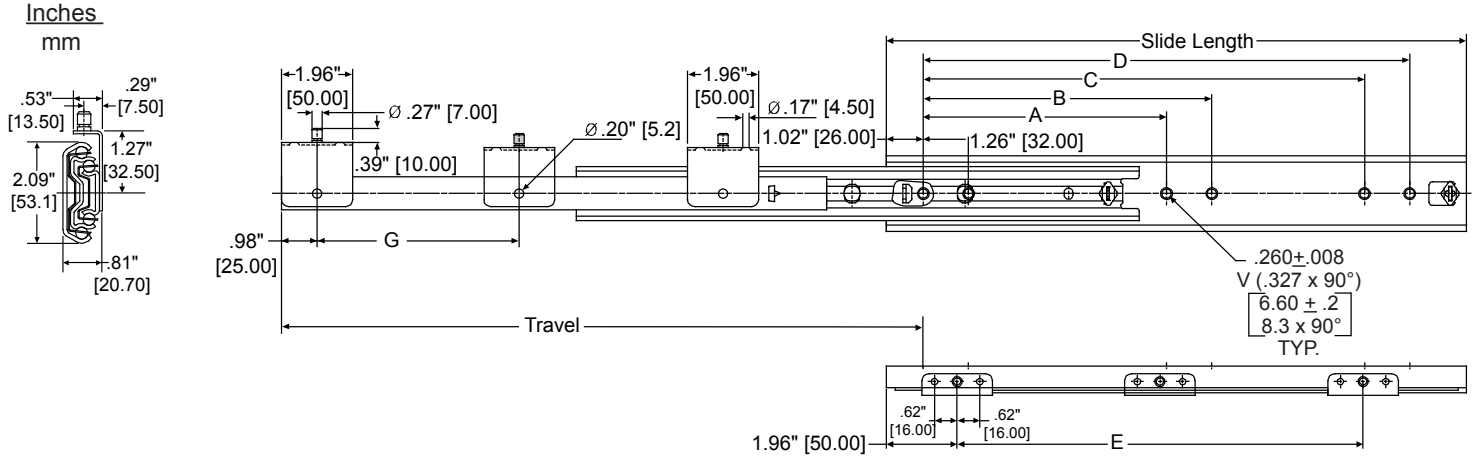

MODEL SS5322

Applications: Ideal for environments subject to corrosion.

Stainless Steel
Over Travel
Hold-in detent
Load Rating Up to 265 lbs. [120 kg.]
.81" [20.7 mm] Slide Thickness



- Finish:** Stainless steel (RoHS compliant)
- Lengths:** 12"–24" [300 mm–600 mm], 28" [700 mm], and 31" [790 mm].**
- Travel:** Over Travel
- Height:** 2.09" [53.1 mm]
- Load Rating:** Up to 265 lbs. [120 kg]*
- Side Space:** .81" [20.6 mm]
- Mounting:** Side or hard mount bracket
- Hardware:** Use #10 [5 mm] flat head or [6 mm] Euro screw. Includes mounting brackets, locator pin, and C-clips (other hardware **not** included).
- Features:** Hold-in detent

Part Number	Slide Length	Travel	A	B	C	D	E	G
SS5322-12	11.81 [300]	13.46 [342]			7.55 [192]	8.81 [224]	6.96 [177]	
SS5322-14	13.78 [350]	15.43 [392]			10.07 [256]	11.33 [288]	8.93 [227]	
SS5322-16	15.75 [400]	17.40 [442]	6.29 [160]	7.55 [192]	11.33 [288]	12.59 [320]	10.90 [277]	
SS5322-18	17.72 [450]	19.37 [492]	7.55 [192]	8.81 [224]	13.85 [352]	15.11 [384]	12.87 [327]	
SS5322-20	19.68 [500]	21.33 [542]	7.55 [192]	8.81 [224]	15.11 [384]	16.37 [416]	14.84 [377]	
SS5322-22	21.65 [550]	23.30 [592]	8.81 [224]	10.07 [256]	17.63 [448]	18.89 [480]	16.81 [427]	
SS5322-24	23.62 [600]	25.27 [642]	10.07 [256]	11.33 [288]	18.89 [480]	20.15 [512]	18.77 [477]	9.38 [238.5]
SS5322-28	27.56 [700]	29.21 [742]	12.59 [320]	13.85 [352]	23.93 [608]	25.19 [640]	22.71 [577]	11.35 [288.5]
SS5322-31	31.10 [790]	32.36 [822]	13.85 [352]	15.11 [384]	26.45 [672]	27.71 [704]	26.65 [677]	13.32 [338.5]

* Load rating based on 80,000 cycles on an 18" slide in an 18" wide drawer. Weight evenly distributed.

** Note: The lengths indicated in inches are approximate conversions from the metric measurements; please see the chart above for exact dimensions.

Installation Instructions

1. Pre-drill mounting holes with a 5.5 mm drill bit. Use access holes provided for mounting slide members. Set back for cabinet member (largest) is 5/64" [2 mm] (Figure 2).
2. Install the cabinet member into the cabinet or rack using #10 [5 mm] countersunk screws or 6 mm Euro screws (Figure 3). Be sure slides are parallel.
3. Mount the inner member (smallest) to the drawer or chassis using brackets provided. Secure brackets to the drawer or chassis with #8 screws. Be sure slides are parallel. For bracket placement see Figures 1 and 4.
4. To secure the drawer or chassis member to the slide use the C-clips provided (Figure 5).
5. Optional mounting includes hard mounting the drawer or chassis member through the drawer or chassis member using #8 screws (Figure 6).
6. Check the slide alignment by opening and closing the drawer or chassis. Any sign of binding indicates a side space, alignment or an out-of-square issue. To check for alignment loosen the screws and adjust the slide position until movement is smooth. Retighten screws and add additional screws if necessary to secure completely.

NOTE: To ensure proper slide operation, make certain that all mounting screws are secure so the screw heads are fully seated inside the slide (Do not use washers). Use #10 (5 mm) countersunk screws or 6 mm Euro screws for cabinet member. To achieve maximum load rating, use all mounting holes and for tall drawers or chassis exceeding 4" [100 mm] mount brackets at centerline of the drawer or chassis. (Figure 4).

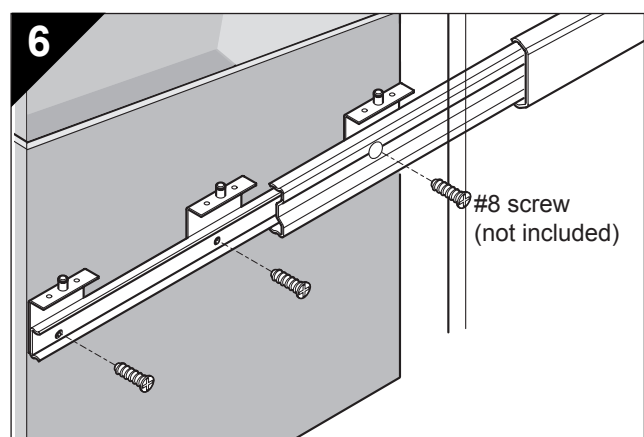
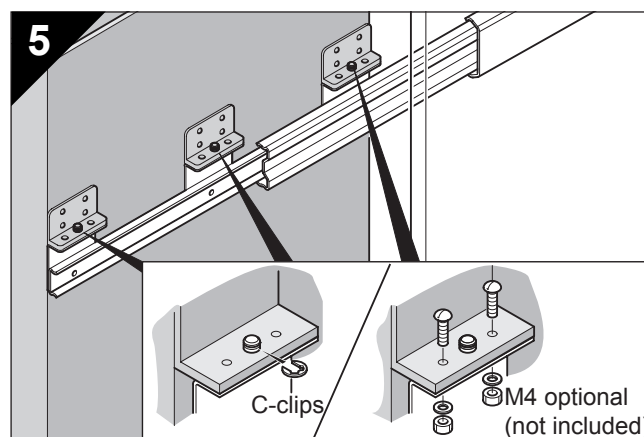
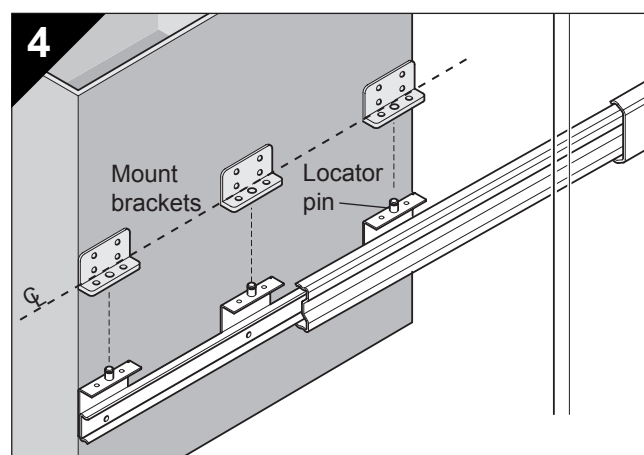
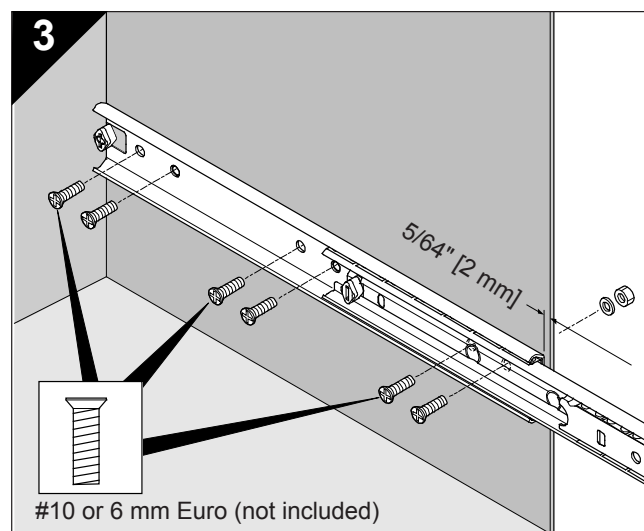
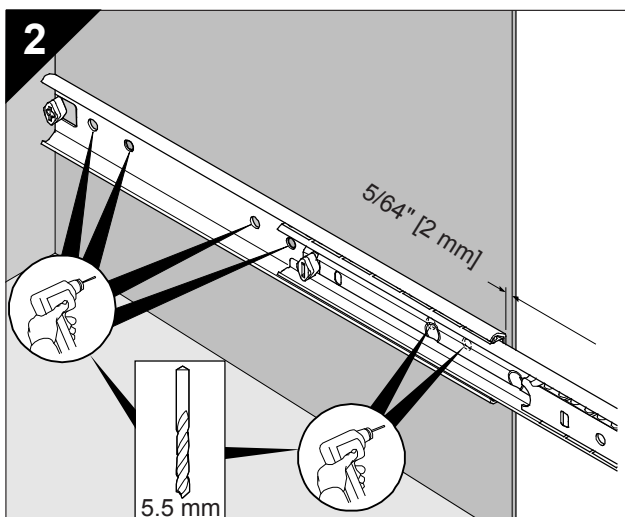
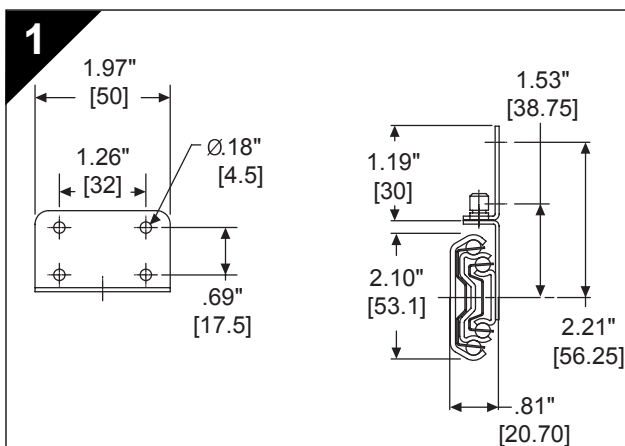

Packaging

Bulk (P) Pack: All lengths are packaged 5 pair per box with installation instructions, mounting brackets, locator pins, and C-clips. Other hardware is **not** included.

Specifications

Slide Members: Stainless Steel
Ball Retainers: Stainless Steel
Ball Bearings: Stainless Steel
Stainless Steel finish is RoHS compliant.

NOTE: Specifications, materials, prices, terms, and delivery are subject to change without notice.

Slide Ordering Instructions

Complete your slide order for model SS5322 by specifying the following information:

	<u>5</u>	<u>Pair</u>	<u>SS</u>	<u>5322</u>	<u>-18</u>	<u>P</u>
Total Slides Required	_____					
Slide Finish	_____					_____
Slide Model	_____				_____	_____
Slide Length	_____			_____	_____	_____
Bulk Packaging	_____					_____

(Includes mounting brackets with locator pins)

Accuride

ACCURIDE INTERNATIONAL INC.

12311 Shoemaker Avenue
Santa Fe Springs, CA 90670

TEL (562) 903-0200
FAX (562) 903-0208
www accuride.com

Manufacturing, Engineering, and Sales

United States • Germany • Japan • Mexico • United Kingdom • China

Copyright © 2007 Accuride International Inc. 3700-9515(1194)-MK121-R2-0610