

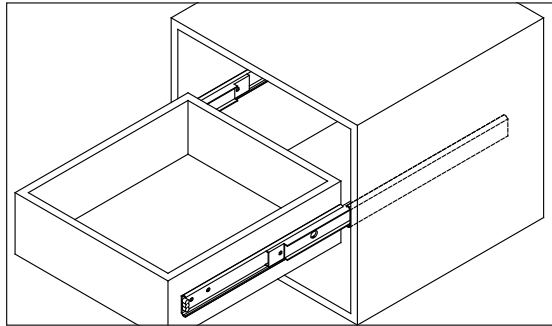

Applications: Ideal for environments subject to corrosion.

## MODEL SS0330

Stainless Steel  
 Full Extension  
 Hold-in Detent  
 Up to 143 lb. [65 kg.] Load Rating  
 .75" [19.1 mm] Slide Thickness



Closed Position

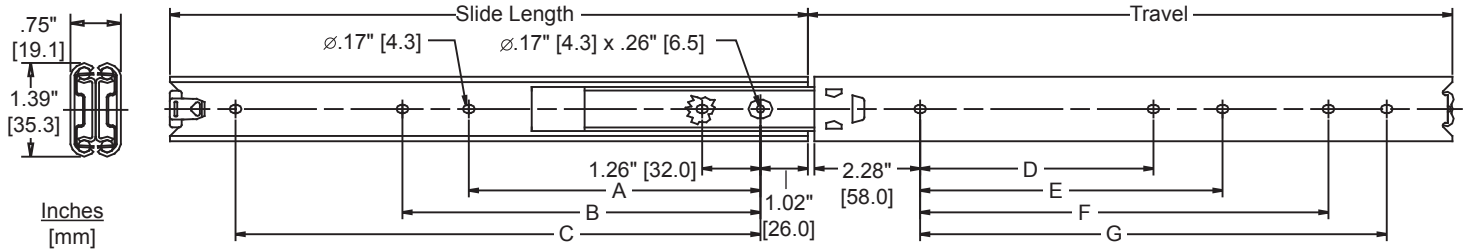

**Finish:** Stainless Steel (RoHS compliant)  
**Length:** 12"–24" [300 mm–600 mm] and 28" [700 mm]\*\*  
**Travel:** Full extension  
**Height:** 1.39" [35.3 mm]  
**Load:** Up to 143 lbs. [65 kg]

**Side Space:** .75+.030/-0.00 [19.1 mm+.76/-0.00]  
**Mounting:** Side or hard mount  
**Hardware:** #8 pan head screws (not included)  
**Features:** Hold-in detent

Part Number	Slide Length	Travel ± .13 [3.2]	A	B	C	D	E	F	G	lb [kg] Load Rating
SS0330-12	11.81 [300]	11.98 [304.5]		7.55 [192]	8.81 [224]			7.55 [192]	8.81 [224]	110 [50]
SS0330-14	13.77 [350]	13.93 [354]		8.81 [224]	10.07 [256]			8.81 [224]	10.07 [256]	121 [55]
SS0330-16	15.74 [400]	15.86 [403]		7.55 [192]	12.59 [320]	6.29 [160]		11.33 [288]	12.59 [320]	121 [55]
SS0330-18	17.71 [450]	17.79 [452]		8.81 [224]	13.85 [352]	7.55 [192]		12.59 [320]	13.85 [352]	143 [65]
SS0330-20	19.68 [500]	19.72 [501]	10.07 [256]	11.33 [288]	16.37 [416]	8.81 [224]	10.07 [256]	15.11 [384]	16.37 [416]	121 [55]
SS0330-22	21.65 [550]	21.67 [550.5]	11.33 [288]	12.59 [320]	18.90 [480]	10.08 [256]	11.34 [288]	16.38 [416]	17.64 [448]	110 [50]
SS0330-24	23.62 [600]	23.62 [600]	12.60 [320]	13.86 [352]	20.16 [512]	11.34 [288]	12.60 [320]	18.90 [480]	20.16 [512]	99 [45]
SS0330-28	27.55 [700]	27.48 [698]	13.86 [352]	15.12 [384]	23.94 [608]	12.60 [320]	13.86 [352]	22.68 [576]	23.94 [608]	77 [35]



Request Info  
 \* \* \*

1-800-453-1692  
[www.aboveboardelectronics.com](http://www.aboveboardelectronics.com)

\*\* Note: The lengths indicated in inches are approximate conversions from the metric measurements; please see the chart above for exact dimensions.

## Installation Instructions

**Important:** Accuride recommends first pre-drilling all mounting holes (Figures 1 and 3). Align the slide as described below to pre-drill.

1. Set the outer member back 5/64" [2 mm] from the cabinet or rack opening. Mount the slide member to the cabinet or rack (Figure 2) using #8 pan head screws (not included). Be sure slides are parallel.
2. For flush-mounted drawers, position the inner member 5/64" [2 mm] back from the front of the drawer or chassis. Mount using #8 pan head screws (Figure 4).
3. Check slide alignment by opening and closing the drawer/chassis. Any sign of binding indicates an issue with side space, alignment, or the cabinet and/or drawer are out of square. To adjust alignment, loosen the screws and adjust the slide position until movement is smooth. Retighten screws. Add additional screws if necessary to secure completely.

**Note:** To ensure proper slide operation, make certain that all mounting screw heads are fully seated inside the slide. Use #8 pan head screws (not included); do not use washers.

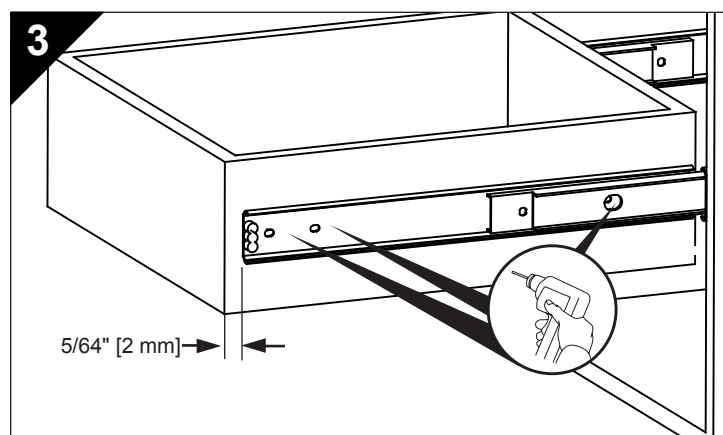
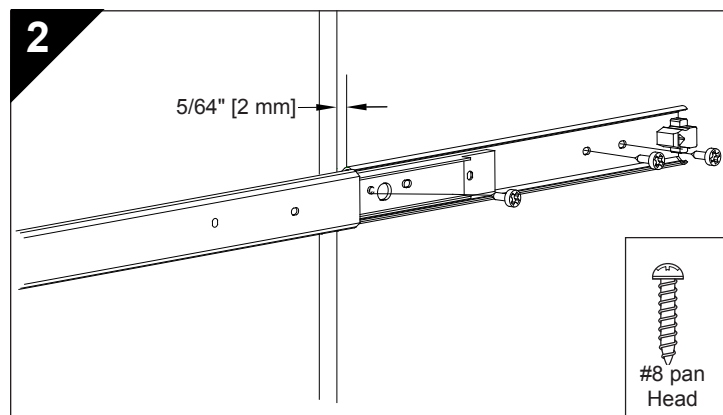
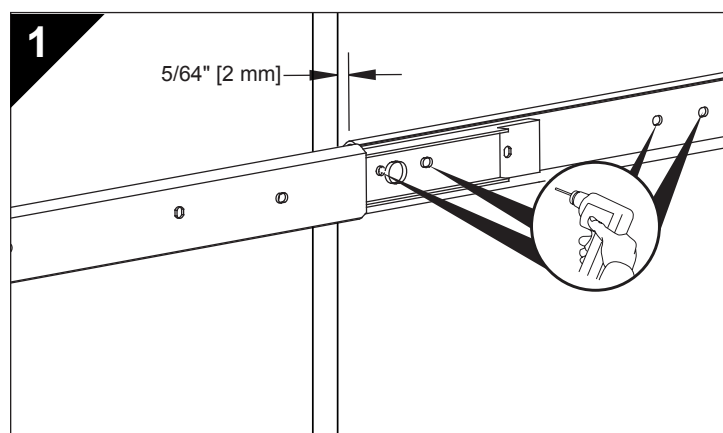

For the most current technical information please visit [www accuride.com](http://www accuride.com)

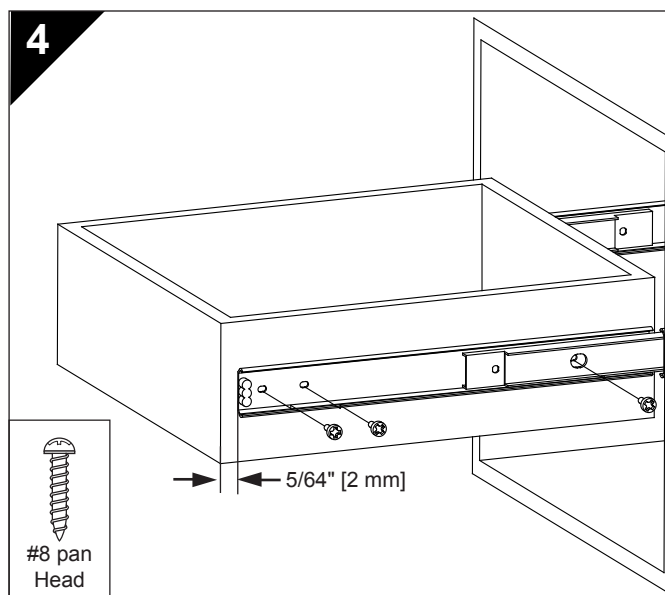

## Packaging

**Bulk (P) Pack:** Fasteners are not included.

- Lengths 12"-14" 5 pair per box
- Lengths 16"-18" 4 pair per box
- Lengths 20"-24" 3 pair per box
- Length 28" 2 pair per box

## Specifications

- Slide Members: Stainless Steel
- Ball Retainers: Stainless Steel
- Ball Bearings: Stainless Steel
- Stainless steel finish is RoHS compliant

**Note:** Specifications, materials, prices, terms, and delivery are subject to change without notice.

## Slide Ordering Instructions

Complete your slide order for model SS0330 by specifying the following information:

	4 Pair	SS	0330	-18 P
Total Slides Required	_____	_____	_____	_____
Slide Finish	_____	_____	_____	_____
Slide Model	_____	_____	_____	_____
Slide Length	_____	_____	_____	_____
Packaging (Fasteners are <b>not</b> included)	_____	_____	_____	_____

# Accuride

ACCURIDE INTERNATIONAL INC.

12311 Shoemaker Avenue  
Santa Fe Springs, CA 90670

TEL (562) 903-0200

FAX (562) 903-0208

[www accuride.com](http://www accuride.com)

Manufacturing, Engineering, and Sales

United States • Germany • Japan • Mexico • United Kingdom • China

Copyright © 2007 Accuride International Inc. 3700-9511(1190)-MK117-R1-0610