

**APPLICATIONS:** EIA rack-mount chassis, power supply, disc/tape drive, industrial workstations, and dispensing equipment. Use model 3301 whenever a medium duty, positive stop, non-disconnect, over travel slide is required.

Medium Duty, Over Travel  
Rack Mounted Slide  
Optional Detent-In (DI) Feature Available  
Up to 150 lb. [68 kg.] Capacity

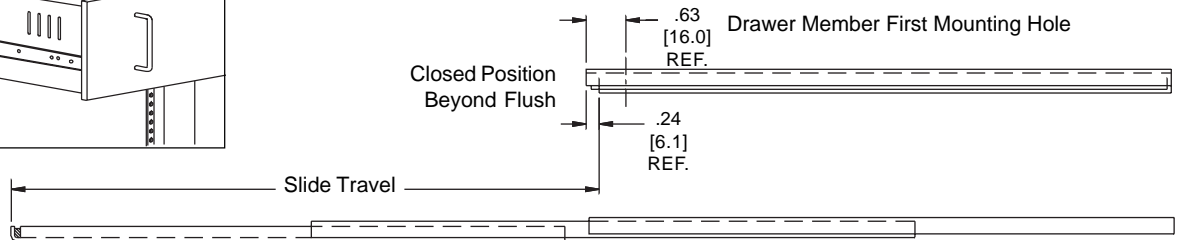
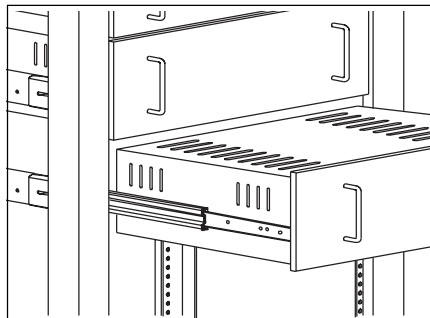

Request Info  
\* \* \*

1-800-453-1692

[www.aboveboardelectronics.com](http://www.aboveboardelectronics.com)

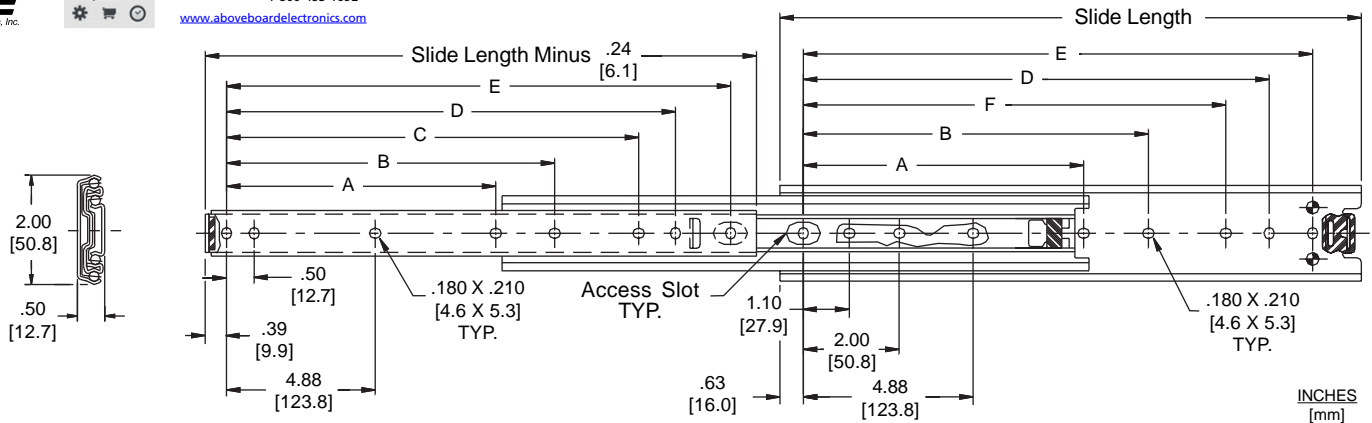

**Finish** Bright electro-zinc (C) plating only  
**Length** 12" - 28" [305mm - 711mm]  
**Travel** Slide length plus 1" [25.4mm]  
**Height** 2.00" [50.8mm]  
**Sidespace** .50" +.015 / -.000  
 [12.7mm + 0.4 / - 0.0]

**Load** See chart \*  
**Mounting** Bracket or hard mounting  
**Movement** Steel ball bearing  
**Hardware** #8 pan head screw  
**Also** Optional detent-in feature (ordered as "DI") available, silenced open/closed.

Part Number	Slide Length	Slide Travel	* Load Rating lb. [kg.] per pr	A	B	C	D	E	F
3301-12	12.00 [305]	13.00 [330]	150 [68.2]		6.38 [162.1]	8.75 [222.3]	9.25 [235.0]	10.25 [260.3]	8.25 [209.6]
3301-14	14.00 [356]	15.00 [381]	148 [67.3]		8.38 [212.8]	10.75 [273.1]	11.25 [285.8]	12.25 [311.2]	10.25 [260.3]
3301-16	16.00 [406]	17.00 [432]	147 [66.8]		10.38 [263.6]	12.75 [323.9]	13.25 [336.6]	14.25 [361.9]	12.25 [311.1]
3301-18	18.00 [457]	19.00 [483]	146 [66.4]	8.38 [212.8]	12.38 [314.4]	14.75 [374.7]	15.25 [387.4]	16.25 [412.7]	14.25 [361.9]
3301-20	20.00 [508]	21.00 [533]	145 [65.9]	9.38 [238.2]	14.38 [365.2]	16.75 [425.5]	17.25 [438.2]	18.25 [463.5]	16.25 [412.7]
3301-22	22.00 [559]	23.00 [584]	140 [63.6]	10.38 [263.6]	16.38 [416.0]	18.75 [476.3]	19.25 [489.0]	20.25 [514.3]	18.25 [463.5]
3301-24	24.00 [610]	25.00 [635]	135 [61.4]	11.38 [289.1]	18.38 [466.8]	20.75 [527.1]	21.25 [539.8]	22.25 [565.1]	20.25 [514.3]
3301-26	26.00 [660]	27.00 [686]	127 [57.7]	12.38 [314.4]	20.38 [517.6]	22.75 [577.9]	23.25 [590.6]	24.25 [615.9]	22.25 [565.1]
3301-28	28.00 [711]	29.00 [737]	120 [54.5]	13.38 [339.8]	22.38 [568.4]	24.75 [628.7]	25.25 [641.4]	26.25 [666.7]	24.25 [615.9]

\* Load rating based on a 16" wide drawer cycled 10,000 times.

## Installation Instructions

### Instructions to Bracket Mount Slides

1. To ensure proper operation of the slides, make certain that all bracket mounting screws are inserted so that only the screw heads are inside the slides. (No washers on the inside of the slides.)
2. Using mounting kits and brackets, install brackets to slide outer members (largest). For adjustment purposes screw the back brackets on loosely. See Figure 1.
3. Install slides into EIA rack with #10 x 32 screws (customer supplied) and secure with bar nuts. Rear adjustment is possible by aligning the back bracket. Do not tighten screws until final adjustment is made.
4. Mount slide drawer members (smallest) to the chassis using #8 pan head screws. Position slides 1/8" from the front edge of the chassis making sure both slides are parallel.
5. It may be necessary to use a hoist for positioning and aligning the chassis when the weight exceeds 50 pounds. Check slide alignment by opening and closing the chassis. Any sign of binding indicates lateral stress or misalignment.
6. Adjust slide position until movement is smooth. Tighten all screws and, if necessary, use more screws to secure slides and complete installation.

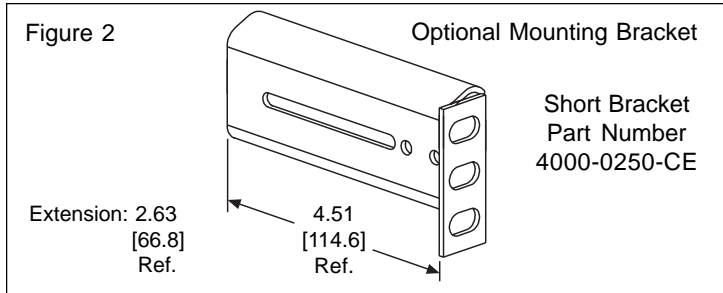
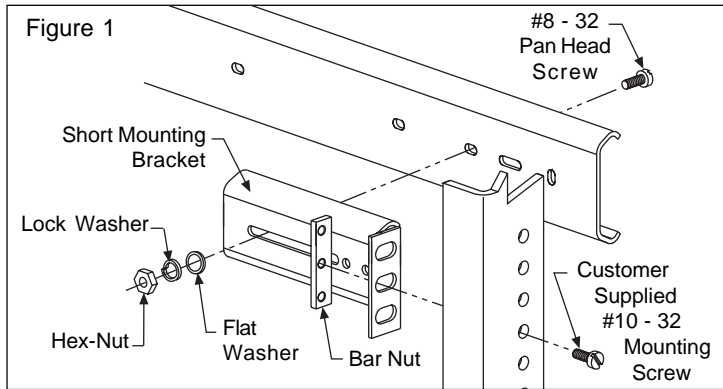

### Instructions to Hard Mount Slides

1. To ensure proper operation of the slides, make certain that all mounting screws are inserted so that only the screw heads are inside the slides. (No washers on the inside of the slides.)
2. With the slides fully extended, install slide cabinet (outer) members into cabinet using #8 pan head screws through uncovered mounting slots. Move intermediate members to allow access to remaining slots. Be sure slides are parallel.
3. Mount slide drawer (inner) members to drawer using #8 pan head screws. Move intermediate members to allow access to remaining slots. Leave all screws loose for future adjustment. Be sure slides are parallel.
4. It may be necessary to use a hoist for positioning and aligning the drawer when the weight exceeds 50 pounds. Check slide alignment by opening and closing the drawer. Any sign of binding indicates lateral stress or misalignment.
5. Adjust slide position until movement is smooth. Tighten all screws and, if necessary, use more screws to secure slides and complete installation.

## Ordering Procedure

Complete your slide order for model 3301 by specifying the following:

Total Slides Required 10 Pair  
 Slide Finish C  
 Slide Model 3301  
 Slide Length -18  
 Optional Detent-In Feature DI  
 Optional Polybag Packaging D

## Optional Mounting Brackets

Optional mounting brackets are ordered as **kits** or in **bulk**.

Each **kit** contains enough brackets and hardware to mount one pair of slides. Order kit part number 4180-0219-XE.

Total Kits Required 10 each  
 Kit Part Number 4180-0219-XE

Bracket **kit** includes the following. See Figure 1.

- 4 short brackets (part number 4000-0250-CE)
  - 1 bracket hardware kit\* (part number 4180-0230-XE)
- (\*Kit contains screws, hex-nuts, washers, bar nuts)

For **bulk**, order 4 each short brackets and 1 hardware kit per pair of slides required. See Figure 2.

Total Brackets Required 40 each  
 Bracket Part Number 4000-0250-CE

Total Hardware Kits Required 10 each  
 Hardware Kit\* Part Number 4180-0230-XE  
 (\*Kit contains screws, hex-nuts, washers, bar nuts)

## Packaging

**Distributor (D) Pack:** Polybag contains one pair of slides and one slide mounting hardware kit. Brackets ordered separately.

Lengths 12" - 20" 10 pair per box  
 Lengths 22" - 28" 5 pair per box

**Bulk (P) Pack:** Slides, optional mounting brackets, and hardware kits are ordered and packaged separately.

Lengths 12" - 22" 10 pair per box  
 Lengths 24" - 28" 7 pair per box

## Specifications

Slide members and ball retainers: Cold rolled steel  
 Ball bearings: Carburized steel

**Note:** Specifications, materials, prices, terms, and delivery are subject to change without notice.

# Accuride

ACCURIDE INTERNATIONAL INC.

12311 Shoemaker Avenue  
 Santa Fe Springs, CA 90670  
 TEL (562) 903-0200  
 FAX (562) 903-0208  
 www accuride.com

Manufacturing, Engineering, and Sales  
 United States • Germany • Japan • Mexico • United Kingdom