

Accuride®

MODEL 3832AA DRAWER ADJUST

Action-Assist™

Vertical Drawer Adjustment Cam
32 mm System Box Drawer Slide
Up To 100 lb. [45.5] Capacity•

APPLICATIONS: For use in wood pedestals, dresser and desk drawers, casework, residential and kitchen cabinetry. **Not intended for lateral file drawer applications.†** Use for side mount only. This product is covered by U.S. (5,980,007), (488,712) and various foreign patents issued and/or pending.

3832AA QUICK REFERENCE

Side Space: (.50" + 0.031) x 2
Length: 12"–28"
Height: Left Hand—1.80"
Right hand—2.89"
Load Rating: 100 lbs. •
Action-Assist™ Feature

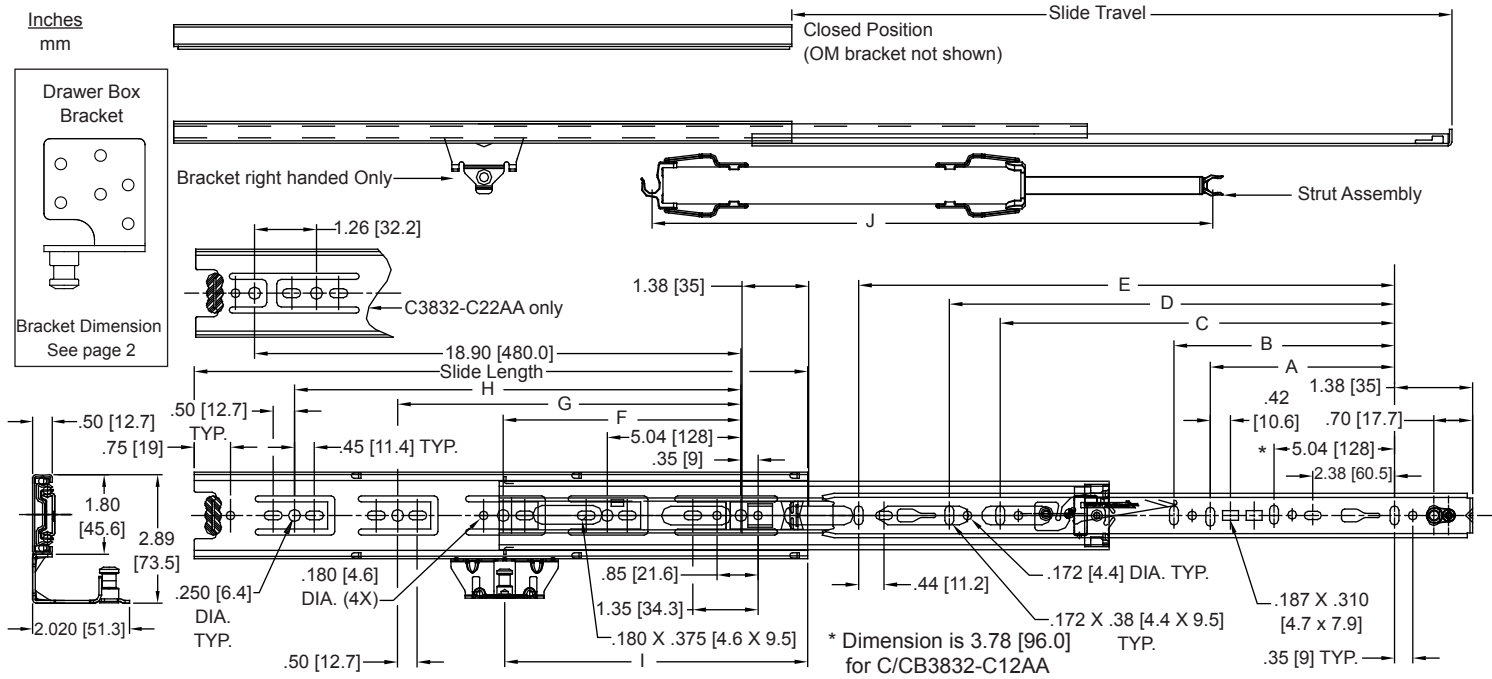

Finish Bright electro-zinc (C), black zinc (CB) ■

Length 12"–28" [300 mm–700 mm]

Travel Full extension

Height 1.80" [45.7 mm] Left hand
2.89" [73.5 mm] Right hand

Load 100 lbs. [45.5kg.] •

Side Space 50" +0.031 / -0.0 [12.7 mm +.8 / -0.0]

Disconnect Front, handed lever

Mounting Side, optional face frame brackets

Hardware Flat head 6 mm Euro System screw or #8 pan head screw.

Ball Bearings C & CB finish: Steel

Features Action-Assist™ feature helps bring drawers to a fully open position and ensures full closure as drawer is closed. Drawer member vertical adjustment cam, silenced open and closed; 32 mm spacing on cabinet member holes

Part Number	Slide Length	Travel	A	B	C	D	E	F	G	H	I	J Extended length	Minimum Drawer Width
3832-C12AA	11.81 [300]	12.00 [305]					9.52 [242]	8.82 [224]			6.04 [153]	11.23 [285.2]	10.00 [254.0]
3832-C14AA	13.78 [350]	14.00 [356]					11.50 [292]	8.82 [224]			7.04 [178]	11.23 [285.2]	10.00 [254.0]
3832-C16AA	15.75 [400]	16.00 [406]					13.47 [342]	8.82 [224]	12.60 [320]		8.04 [204]	11.23 [285.2]	10.00 [254.0]
3832-C18AA	17.72 [450]	18.00 [457]			12.60 [320]		15.43 [392]	8.82 [224]	13.86 [352]		9.04 [229]	14.83 [276.6]	12.00 [304.8]
3832-C20AA	19.69 [500]	20.00 [508]			12.60 [320]		17.40 [442]	8.82 [224]	16.38 [416]		10.04 [255]	14.83 [276.6]	12.00 [304.8]
3832-C22AA	21.65 [550]	22.00 [559]			12.60 [320]	16.38 [416]	19.37 [492]	8.82 [224]	13.86 [352]	17.64 [448]	11.04 [280]	14.83 [276.6]	12.00 [304.8]
3832-C24AA	23.62 [600]	24.00 [610]	8.82 [224]		16.38 [416]		21.34 [542]	8.82 [224]	13.86 [352]	18.90 [480]	12.04 [305]	18.33 [465.5]	14.00 [355.6]
3832-C26AA	25.59 [650]	26.00 [660]	8.82 [224]		16.38 [416]	21.42 [544]	23.31 [592]	8.82 [224]	13.86 [352]	21.42 [544]	13.04 [331]	18.33 [465.5]	14.00 [355.6]
3832-C28AA	27.56 [700]	28.00 [711]	8.82 [224]	11.34 [288]	16.38 [416]	21.42 [544]	25.28 [642]	8.82 [224]	13.86 [352]	21.42 [544]	14.04 [356]	18.33 [465.5]	14.00 [355.6]

† A lateral file drawer is wider than it is deep
• Load rating based on 18" slides mounted in a 16" wide drawer cycled 50,000 times.
■ RoHS compliant.

- To accommodate the Action-Assist™ mechanism, there is a minimum drawer width that is determined by the slide length, see below.

Slide Length	Min. Drawer Width
12"–16"	10"
18"–22"	12"
24"–28"	14"

NOTE: Minimum 7/16" gap required from back of drawer box to inside cabinet wall.

- Important:** For inset drawer bottoms, notch the back of the drawer box so it is flush with the drawer bottom (Figure 1). The back of the drawer must be flush to the drawer bottom to accommodate the bracket used to connect the Action-Assist™ strut assembly.
- Be sure to allow adequate side space between the drawer box and the cabinet (Figure 2) for optimal slide operation. There must be a minimum of 1" below the drawer bottom to provide clearance for the Action-Assist™ mechanism.

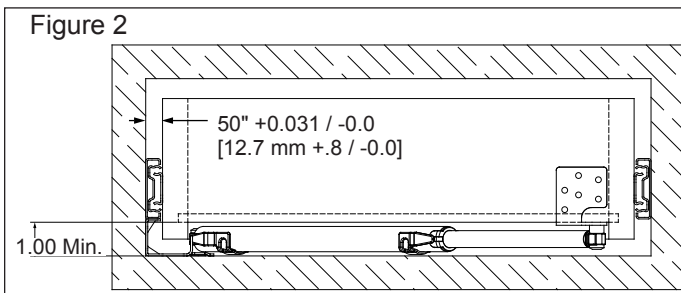
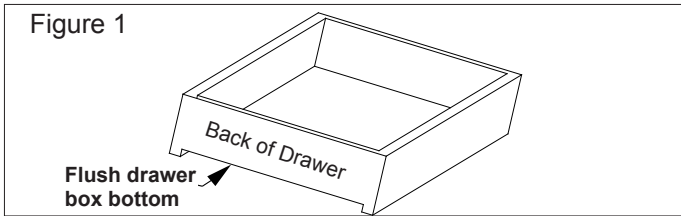

Drawer Bracket Installation

- The position of the bracket on the back of the drawer is based on slide length (Figure 3). See dimension "W" for the placement distance from the drawer side to the edge of the bracket. Align the bracket to the bottom of the drawer box and install screws. **Note:** A jig is under development that will assist in locating the drawer bracket position (P/N 4180-0709-YE).

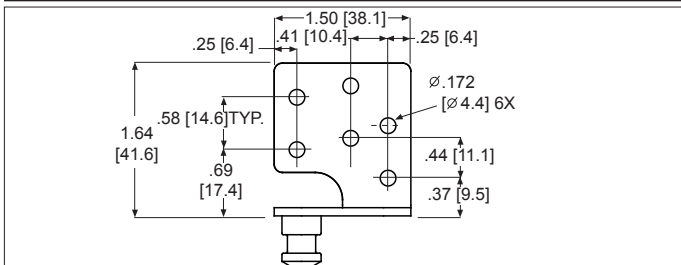
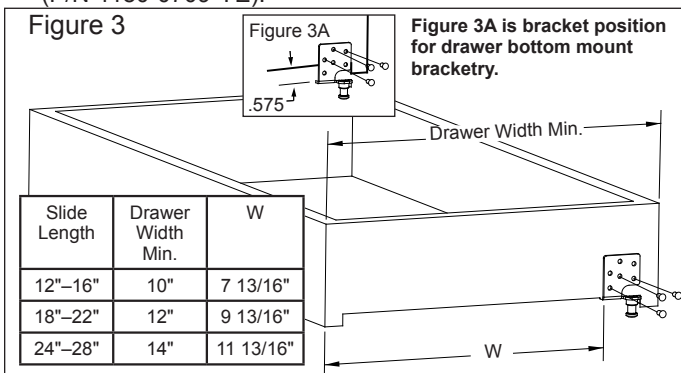

- Separate slide members. To disconnect drawer member from cabinet member, lift up the disconnect lever on the left hand slide; push the disconnect lever down on the right hand slide.
- Overlay drawer fronts
Conventional mounting: see Figure 4 for slide positioning.
32 mm system mounting: see Figure 5 for slide positioning.
- Inset drawer fronts: set the slide back the thickness of the drawer plus 1/8" [3.2 mm].

Important: There must be a minimum of 2" [50.5 mm] from the location of the installed slide centerline to the base of the cabinet, dividing panel, or next drawer box, to allow adequate room for the Action-Assist™ strut assembly.

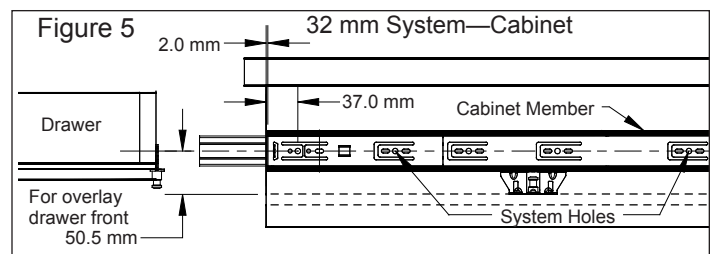
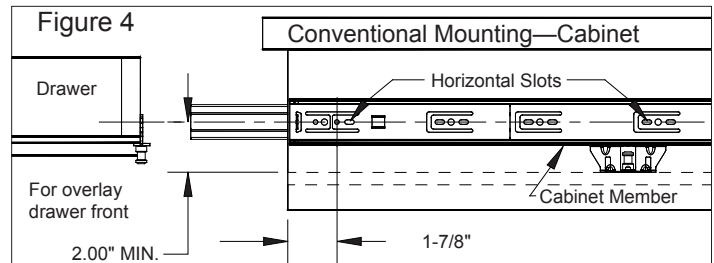

- Use only the 32 mm system holes or wood screw holes located at the tip of the breathing tabs. Do not use any other holes on the cabinet member for mounting (Figure 6).

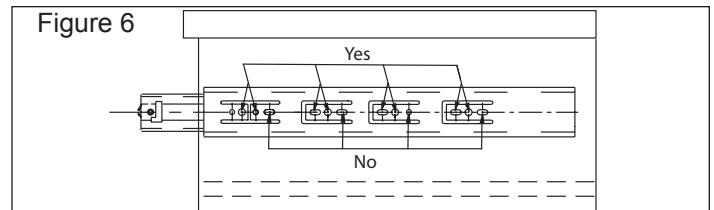

Drawer Member Installation

- For **flush-bottom drawers**, the centerline of the drawer member must be located 1" [25.1 mm] from the drawer bottom. For **inset bottom drawers**, the centerline must be 1.5" [37.8 mm], presuming the inset is .50" (Figure 7). **Note:** A jig is under development that will assist in locating the drawer member centerline (P/N 4180-0709-YE).

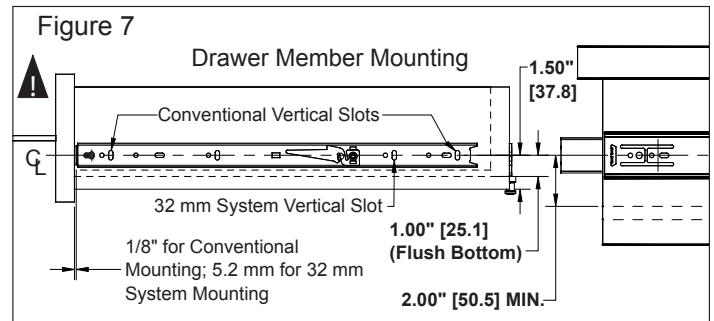

- Install the drawer member with a screw through the cam adjuster and a screw through a hole or slot at the rear (Figure 8).

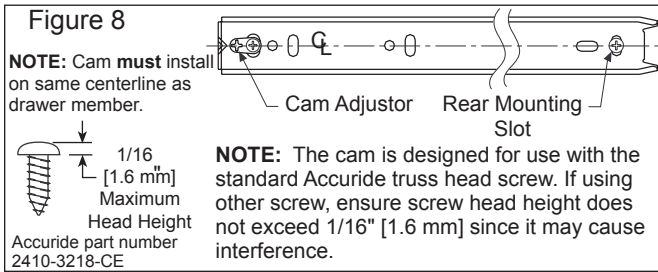

Action-Assist™ Strut Installation

11. After the cabinet members are installed, attach the Action-Assist™ strut assembly to the cabinet member bracket (Figure 9, position "A"). The strut clips on to the bracket pin.
12. Then, insert the drawer and close completely. Open and release the drawer by pulling it out of the cabinet approximately 2–3 inches. Locate the other end of the strut assembly and snap the clip onto the drawer bracket pin (Figure 8, position "B"). Fully close the drawer and cycle a few times to check movement and strut function.

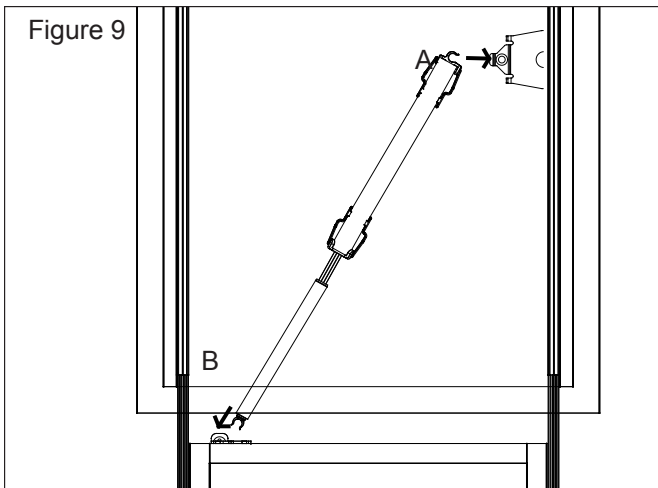

13. There is a neutral zone at the mid-point of the slide travel where the drawer will remain in a steady position (Figure 10) between opening and closing actions.

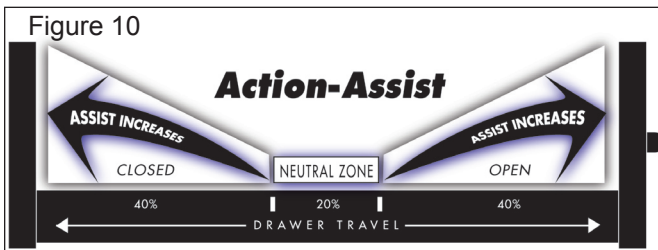

Drawer Installation and Adjustment

14. Ensure the ball bearing retainers in the cabinet members are fully forward. Install the drawer into the cabinet and close the drawer.
15. Open the drawer and rotate the cam with a Phillips or Pozi screwdriver to vertically position the drawer in relation to the cabinet. Vertical adjustment is +/- 1/16" from the center up and down.
16. Install additional set screws to secure. Install drawer pulls or knobs after the set screws are in place.



For the most current technical information please visit www.accuride.com

Available in D-pack or bulk packaging.

Distributor (D) Pack: All lengths are packaged 1 pair per box. Box includes one pair of slides with strut assembly, drawer bracket and mounting screws.

Bulk (X) Pack: All lengths are packaged 5 pair per box. One pair includes slides, strut assembly, and drawer bracket. Screws not included.

Specifications

Slide members and ball retainers: Cold rolled steel
 Ball bearings: Carburized steel/acetal polymer
 RoHS compliant.

NOTE: Specifications, materials, prices, terms, and delivery are subject to change without notice.

Slide ordering Instructions

Complete your slide order for Accuride models 3832C by specifying the following:

Total Required Slides 5 Pair C 3832-C 18 AA D
 Slide Finish _____
 Slide Model _____
 Slide Length _____
 Action Assist _____
 D-Pack Packaging _____

Optional Hardware Kits

Face frame brackets are ordered as a kit or in bulk. Brackets are available in clear zinc finish only. Mounting screws are not included.

To order kits, specify part number 4180-0322-XE.

Each kit contains: 2 front brackets, 2 rear brackets, and installation instructions. Order 1 kit per pair of slides.

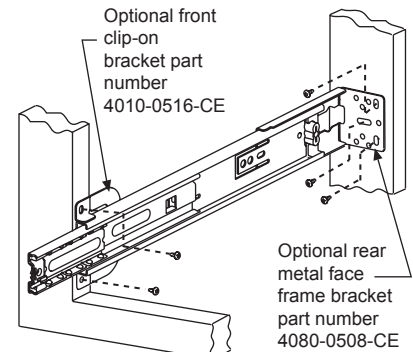

For bulk, order 2 front brackets (P/N 4010-0516-CE) and 2 rear brackets (P/N 4080-0508-CE) per pair of slides.

Pilaster kit (P/N 4180-0266-XE) The kit contains 4 each pilaster brackets, 4 each mounting screws, 4 each hex nuts, and 8 each washers.

Jig Guide Kit Number (4180-0709-YE) kit includes the Installation Jig and Technical Sheet in a polybag.



ACCURIDE INTERNATIONAL INC.

12311 Shoemaker Avenue
 Santa Fe Springs, CA 90670

TEL (562) 903-0200
 FAX (562) 903-0208
www.accuride.com

Manufacturing, Engineering, and Sales
 United States • Germany • Japan • Mexico • United Kingdom • China