

**APPLICATIONS:** Utility vehicles, work stations and shelving units, bin, trays or deep storage drawers in commercial and residential settings.

Heavy-Duty Slides  
Full Extension  
Up to 273 lbs. (124 kg.) Capacity\*

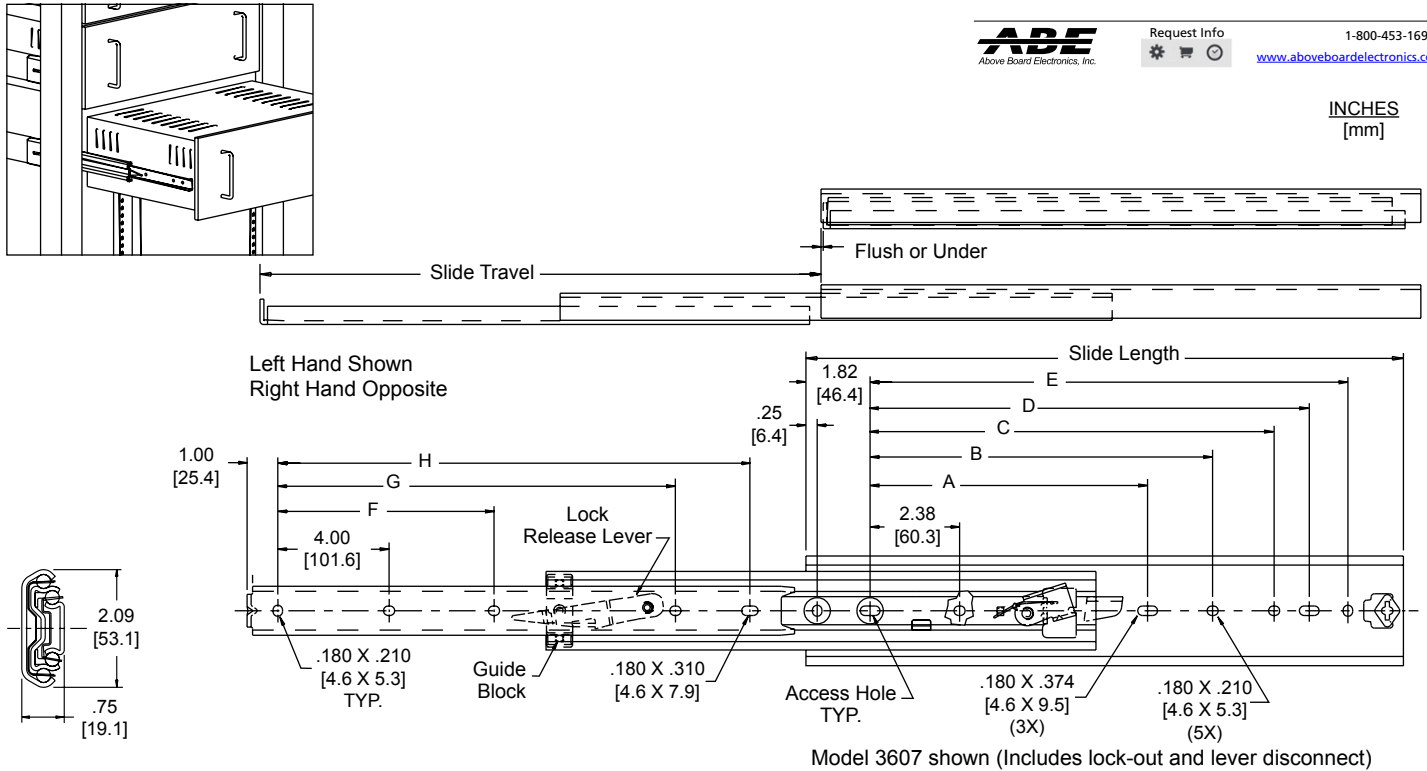

1-800-453-1692  
[www.aboveboardelectronics.com](http://www.aboveboardelectronics.com)



<b>Finish</b>	Clear zinc (C)	<b>Travel</b>	Full Extension
<b>Length</b>	Even lengths 12" to 28" [305 mm–711 mm]	<b>Mounting</b>	Bracket or side/hard mount
<b>Height</b>	2.09" [53.1 mm]	<b>Hardware</b>	#8 pan head screws
<b>Side Space</b>	.75" + .030/ - .000 [19.1 mm + .76/ - .00]	<b>Movement</b>	Carburized steel ball bearings
<b>Load Capacity</b>	Moderate use: Up to 273 lbs. [124 kg] * Frequent use: Up to 200 lbs. [91 kg] **	<b>Features</b>	Models 3657, Stop-out + lever disconnect Models 3607, Lock-out + lever disconnect

Part Number	Slide Length	Slide Travel	A	B	C	D	E	F	G	H
C36XX-12	12.00 [305]	12.00 [305]		5.33 [135.4]	7.05 [179.1]	8.05 [204.5]	9.05 [229.9]			9.00 [228.6]
C36XX-14	14.00 [356]	14.00 [356]		7.33 [186.2]	9.05 [229.9]	10.05 [255.3]	11.05 [280.7]			11.00 [279.4]
C36XX-16	16.00 [406]	16.00 [406]		9.33 [237.0]	11.05 [280.7]	12.05 [306.1]	13.05 [331.5]		10.13 [257.3]	13.00 [330.2]
C36XX-18	18.00 [457]	18.00 [457]		11.33 [287.8]	13.05 [331.5]	14.05 [356.9]	15.05 [382.3]		12.13 [308.1]	15.00 [381.0]
C36XX-20	20.00 [508]	20.00 [508]	8.50 [215.9]	13.33 [338.6]	15.05 [382.3]	16.05 [407.7]	17.05 [433.1]	8.00 [203.2]	14.13 [358.9]	17.00 [431.8]
C36XX-22	22.00 [559]	22.00 [559]	9.50 [241.3]	15.33 [389.4]	17.05 [433.1]	18.05 [458.5]	19.05 [483.9]	9.00 [228.6]	16.13 [409.7]	19.00 [482.6]
C36XX-24	24.00 [610]	24.00 [610]	10.50 [266.7]	17.33 [440.2]	19.05 [483.9]	20.05 [509.3]	21.05 [534.7]	10.00 [254.0]	18.13 [460.5]	21.00 [533.4]
C36XX-26	26.00 [660]	26.00 [660]	11.50 [292.1]	19.33 [491.0]	21.05 [534.7]	22.05 [560.1]	23.05 [585.5]	11.00 [279.4]	20.13 [511.3]	23.00 [584.2]
C36XX-28	28.00 [711]	28.00 [711]	12.50 [317.5]	21.33 [541.8]	23.05 [585.5]	24.05 [610.9]	25.05 [636.3]	12.00 [304.8]	22.13 [562.1]	25.00 [635.0]

\* Load rating based on a pair of slides mounted in a 16" wide drawer cycled 10,000 times.

\*\* Load rating based on side mount testing criteria for Model 3640A: a pair of 18" slides on a 42" wide drawer, cycled 75,000 times.

## Installation Instructions

### Instructions to Bracket Mount

- To ensure proper operation of the slides, make certain all mounting screws are inserted so the screw heads are inside the slides. (No washers on the inside of the slides.)
- Separate slide members by pushing up on lock release lever.  
**NOTE:** Slides are handed. Ensure that left hand drawer members mate with left hand cabinet members, etc., to prevent damage upon re-connect.
- Using mounting kits and brackets, mount brackets to slide cabinet members (largest). For adjustment purposes screw the rear brackets on loosely.
- Install slides into EIA rack with (customer supplied) #10-32 screws and secure with bar nuts. Rear adjustment is possible by aligning the back bracket. Do not tighten screws until final adjustment is made.
- Mount slide drawer members (smallest) to the chassis. Position slides 1/8" [3.2 mm] from the front edge of the chassis making sure both slides are parallel.
- With cabinet members in the closed position and ball retainers fully forward, install chassis by engaging the slide members and close completely. Check slide alignment by opening and closing the chassis. Any sign of binding indicates lateral stress or misalignment.
- Adjust slide position until movement is smooth. Tighten all screws if necessary, use more screws to secure slides and complete installation.

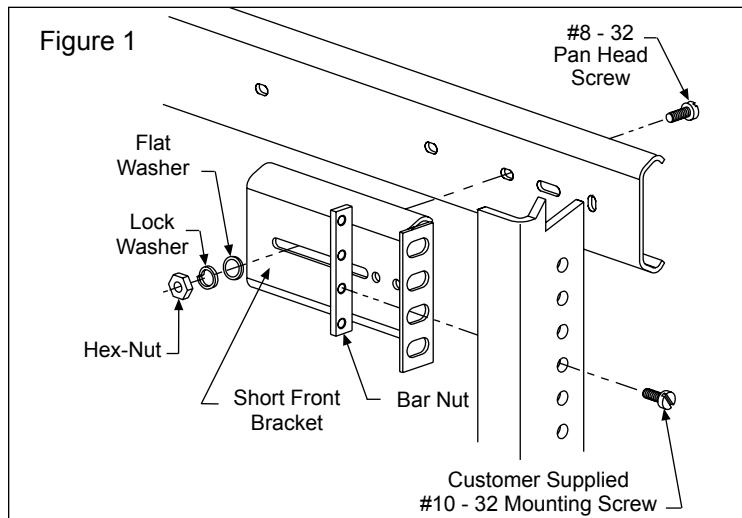

### Instructions to Hard Mount

- Follow steps 1 and 2 of "Bracket Mount" instructions.
- With slides fully extended, install slide cabinet members (largest) into cabinet using #8 pan head screws. Be sure slides are parallel.
- Mount slide drawer members (smallest) to chassis. Leave all screws loose for future adjustment. Make sure slides are parallel.
- Follow steps 6 and 7 of "Bracket Mount" instructions.

## Packaging

**Distributor (D) Pack:** All lengths are packaged 5 pair per box. Polybag includes one pair of slides packaged with screws.

**Bulk (P) Pack:** Lengths 12"-20" 14 each per box  
Lengths 22"-28" 10 each per box

A pair includes right and left hand slides. Order optional bracket mounting hardware kit (part number 4180-0220-XE) separately.

### Slide Ordering Instructions

Complete your slide order for Accuride Models 3607 (lock out) or 3657 by specifying the following:

Total Slides Required \_\_\_\_\_ 10 Pair C 36XX -18 D  
Slide Finish \_\_\_\_\_  
Slide Model \_\_\_\_\_  
Slide Length \_\_\_\_\_  
Optional Polybag Packaging (includes mounting screws) \_\_\_\_\_

### Optional Hardware Kits—Ordered Separately

Mounting bracket kits are ordered separate. Each kit contains enough brackets and hardware to mount one pair of slides. Order kit part number 4180-0220-XE.

Total Bracket Kits Required \_\_\_\_\_ 10 Each 4180-0220-XE  
Optional Bracket Kit Part Number \_\_\_\_\_  
Bracket kit includes the following. See Figure 1.

2 short front brackets (part number 4000-0501-CE)  
2 long rear brackets (part number 4000-0502-CE)  
1 bracket hardware kit\* (part number 4180-0232-XE)  
(\*Kit contains screws, hex-nuts, washers, bar nuts.)

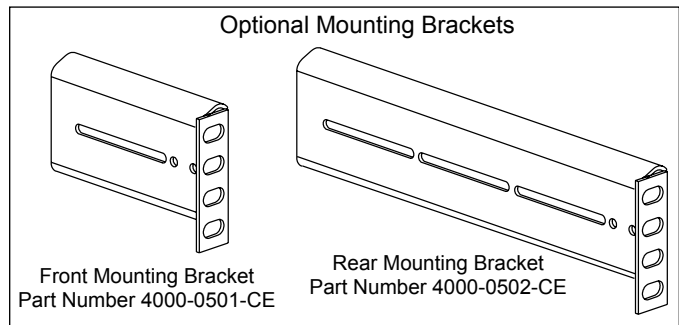

### Specifications

Slide members and ball retainers: Cold rolled steel  
Ball bearings: Carburized steel  
RoHS compliant.

**NOTE:** Specifications, materials, prices, terms, and delivery are subject to change without notice.

# Accuride

ACCURIDE INTERNATIONAL INC.

12311 Shoemaker Avenue  
Santa Fe Springs, CA 90670

TEL (562) 903-0200  
FAX (562) 903-0208  
www accuride.com

Manufacturing, Engineering, and Sales

United States • Germany • Japan • Mexico • United Kingdom • China

Copyright © 2012 Accuride International Inc. 3700-9222(9041)-MK031-R9-1113