



1-800-453-1692
www.aboveboardelectronics.com

APPLICATIONS: Designed for use in a variety of heavy-duty metal applications for wider drawers used in truck bodies and emergency vehicles. **This product is covered by U.S. and various foreign patents issued and/or pending.**

MODEL 9322E
Non-Locking Companion
Pocket and Bayonet Mount

MODEL 9328E
Lock-in & Lock-out with Front Release
Pocket and Bayonet Mount

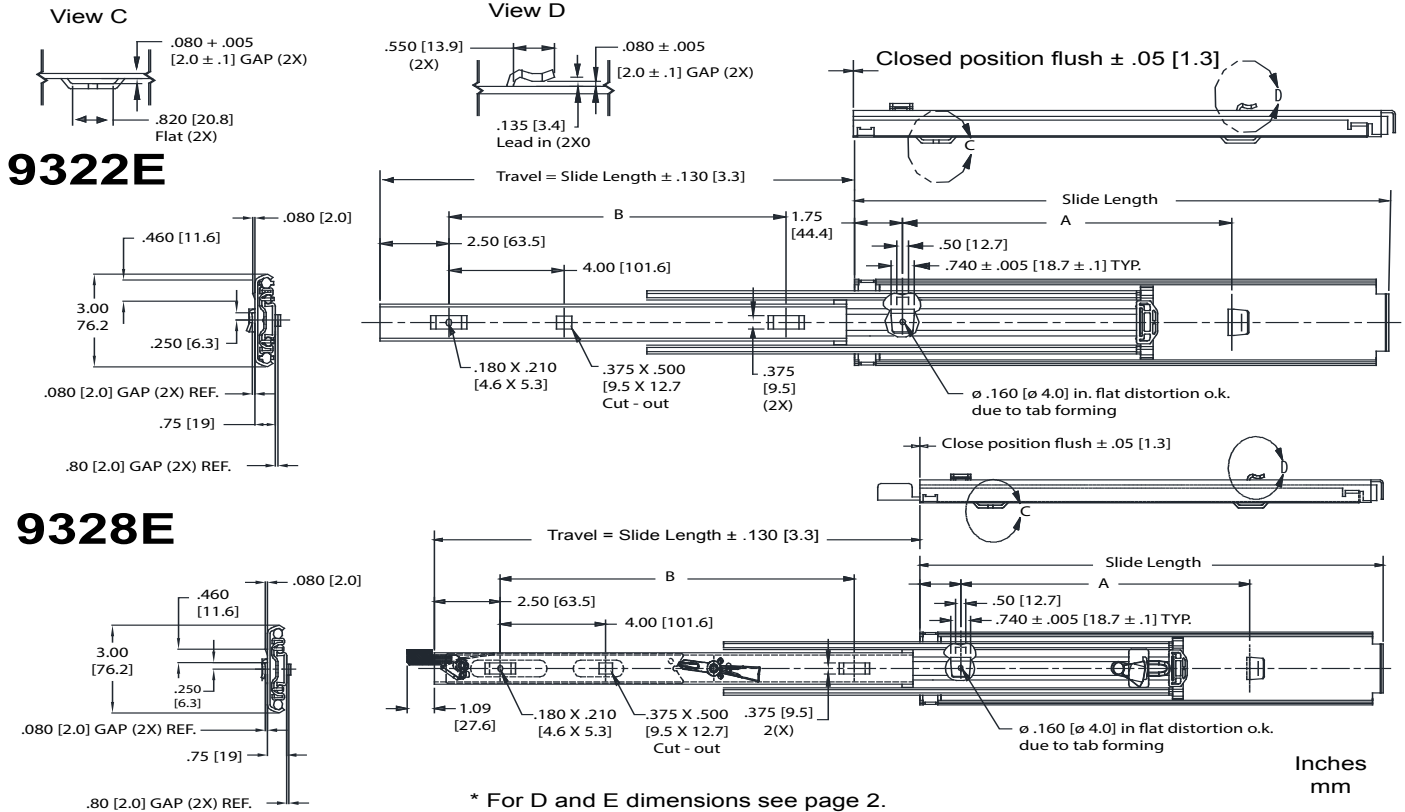

Finish	Bright electro-zinc (C) plating*	Side Space	.75" (+.030, -.000) [19 mm (+.76, -.00)]
Lengths	Even lengths 10"-36" and 40", 42", 48" and 60" [254-914, 1016, 1067, 1219, 1524 mm]	Drawer Width	Maximum 32" wide
Travel	Full extension	Mounting	Side; bayonet and pocket
Height	3.00" [76.2 mm]	Hardware	Not included. Recommended: Drawer: #8 pan head self-tapping screw Cabinet: #10 pan head self-tapping screw
Load	360 lbs. [163.68 kg.]	Features	Silenced for quiet operation. 9328E offers lock-in and lock-out with front release.

Part number	Slide Length	Travel	A	B	Part Number	Slide Length	Travel	A	B	Part Number	Slide Length	Travel	A	B
9322-E10	10.00	10.00	5.50	5.50	9322-E22	22.00	22.00	15.50	12.50	9322-E34	34.00	34.00	25.50	22.50
9328-E10	[254.0]	[254.0]	[139.7]	[139.7]	9328-E22	[558.8]	[558.8]	[393.7]	[317.5]	9328-E34	[863.6]	[863.6]	[647.7]	[571.5]
9322-E12	12.00	12.00	7.50	6.00	9322-E24	24.00	24.00	15.50	12.50	9322-E36	36.00	36.00	30.50	27.50
9328-E2	[304.8]	[304.8]	[190.5]	[152.4]	9328-E24	[609.6]	[609.6]	[393.7]	[317.5]	9328-E36	[914.4]	[914.4]	[774.7]	698.5]
9322-E14	14.00	14.00	9.50	8.00	9322-E26	26.00	26.00	15.50	15.50	9322-E40	40.00	40.00	30.50	27.50
9328-E14	[355.6]	[355.6]	[241.3]	[203.2]	9328-E26	[660.4]	[660.4]	[393.7]	[393.7]	9328-E40	[1016.0]	[1016.0]	[774.7]	698.5]
9322-E16	16.00	16.00	12.50	10.00	9322-E28	28.00	28.00	15.50	15.50	9322-E42	42.00	42.00	30.50	27.50
9328-E16	[406.4]	[406.4]	[317.5]	[254.0]	9328-E28	[711.2]	[711.2]	[393.7]	[393.7]	9328-E42	[1066.8]	[1066.8]	[774.7]	698.5]
9322-E18	18.00	18.00	12.50	10.50	9322-E30	30.00	30.00	18.50	17.50	9322-E48	48.00	48.00	30.50	27.50
9328-E18	[457.2]	[457.2]	[317.5]	[266.7]	9328-E30	[762.0]	[762.0]	[469.9]	[444.5]	9328-E48	[1219.2]	[1219.2]	[774.7]	698.5]
9322-E20	20.00	20.00	15.50	10.50	9322-E32	32.00	32.00	20.50	17.50	9322-E60	60.00	60.00	40.50	37.50
9328-E20	[508.0]	[508.0]	[393.7]	[266.7]	9328-E32	[812.8]	[812.8]	[520.7]	[444.5]	9328-E60	[1524.0]	[1524.0]	[1028.7]	[952.5]

* Load rating based on an 22" slide in a 24" wide drawer cycled 10,000 times.
• RoHS compliant

Cabinet Cut-Out Recommendation

See figure 1 for hat section cut-out details.

Same cut-out details apply to locking and non-locking slide.

Front and rear hat sections are identical.

The .200 dia. round hole is used for optional #10 fixing screw. See installation details for proper use of this feature.

Attach the hat sections to the cabinet sidewall using the pitch pattern recommended in figure 2.

For A dimensions, see table on front page.

The vertical cut-out at the front of the rear hat section accepts the rear cabinet member tab (see figure 3).

NOTE: Minimum recommended material thickness for hat section is .060" [1.52mm] or 16 gauge.

Mounting Slide to Cabinet

1. Insert the cabinet member rear bayonet tab into the rear hat section cut-out (see figure 3).
2. Lower the slide until the front bayonet tab engages the front cut-out.
3. Insert the front tab into the trapezoidal cut-out. Push firmly downward until the tab snaps into place and the retention lug is engaged (see figure 3).
4. The retention lug prevents the cabinet member from lifting and disengaging from the cabinet.
5. When desired, an optional #10 self-tapping screw (customer provided) can be used to fix the slide firmly in the cabinet. Run the screw from the hat section hole into the front bayonet tab.
6. Repeat procedure on opposite side of cabinet for the companion slide.
7. The companion slide can be a locking or non-locking slide. Same installation procedure applies.

Drawer Cut-Out Recommendations

See figure 4 for drawer cut-out details.

Same cut-out details apply for locking and non-locking slides.

The .140 dia. round hole is used for optional #8 fixing screw. See installation details for proper use of this feature.

For B dimension (figure 5) see table on front page. For optimum slide performance, it is recommended that the slide centerline be located at the centerline of the drawer side or slightly toward the plane of the drawer pull.

Cut-out recommendation is based on 14 gauge material.

If a thinner material is used, adjustment to the cut-outs must be made to ensure a proper fit. Refer to the table below for the recommended modifications.

Material Gauge	Material Thickness	D	E
14	.075 [1.90]	.855 [21.72]	.815 [20.70]
16	.060 [1.52]	.865 [21.97]	.825 [20.96]

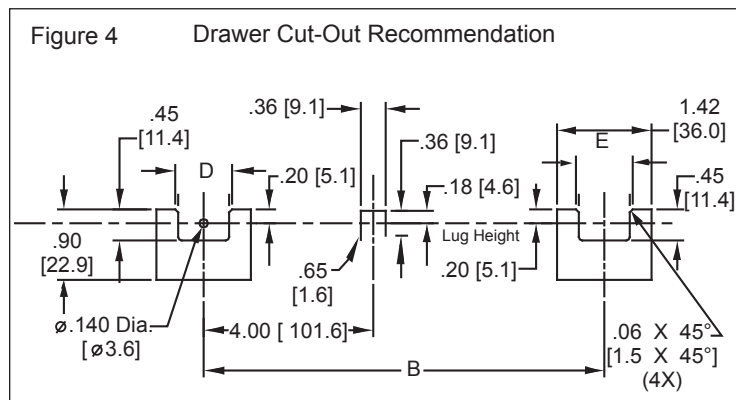
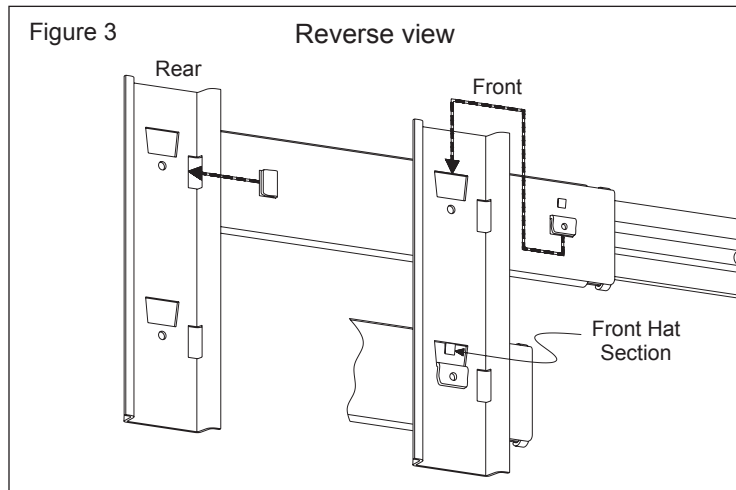
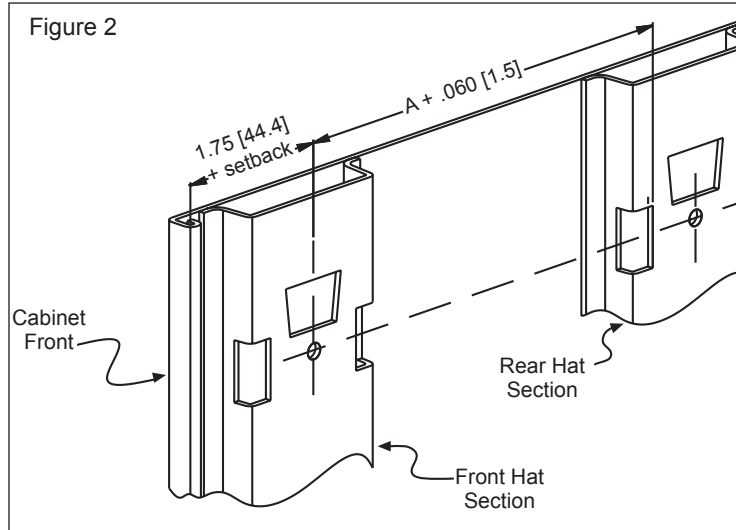
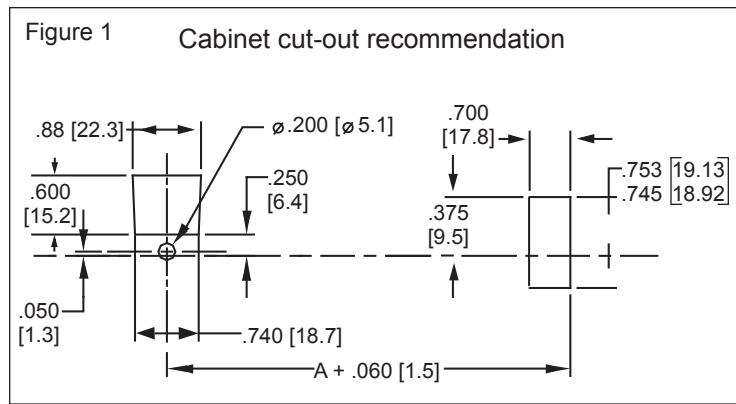

- Using recommended placement of drawer bayonets (figure 5), extend both right and left hand slide drawer members. See Figure 6.
- Position rear drawer tabs into both rear slide pockets. Guide front tabs into front pockets and push firmly into place making sure retention lug snaps into cut-out on slide drawer member. See Figure 6.
- The drawer retention lug will adequately protect the drawer from lifting and disengaging from the slide.
- When desired, an optional #8 self-tapping screw (customer provided) can be used through the front mounting pocket to fix the drawer firmly in place.

Slide Ordering Instructions

The locking slide is model 9328E. The non-locking companions slide is model 9322E. Both slides are handed.

The locking slide can be used on the right hand side, left hand side, or both sides of the unit.

After the length, specify L for left hand and R for right hand. See below for the various left and right locking and non-locking combinations.

Left Hand Locking System: 9328-EXX-L & 9322-EXX-R
 Right Hand Locking System: 9322-EXX-L & 9328-EXX-R
 Left & Right Hand Locking: 9328-EXX-L & 9328-EXX-R
 Left & Right Hand Non-Locking: 9322-EXX-L & 9322-EXX-R
 (XX designates slide length)

Complete your slide order by specifying the following:

Model 9328E Locking Slide

100 Each C 9328 -E16 -L

Total Required Slides _____

Slide Finish _____

Locking Model Number _____

Slide Length _____

Left Hand Slide _____

Model 9322E Non-Locking Slide

100 Each C 9322 -E16 -R

Total Required Slides _____

Slide Finish _____

Companion Model Number _____

Slide Length _____

Right Hand Slide _____

Packaging

Slides are available in bulk (P) packaging only. Locking slides and non-locking companion slides are ordered and packaged separately.

Models 9328E and 9322E:

Lengths 10"-20"	8 each per box
Lengths 22"-36"	4 each per box
Lengths 40"-60"	2 each per box

Specifications

Slide members: Cold rolled steel

Ball bearings: Carburized steel

RoHS compliant

Note: Specifications, materials, prices, terms, and delivery are subject to change without notice.

For the most current technical information visit www.accuride.com

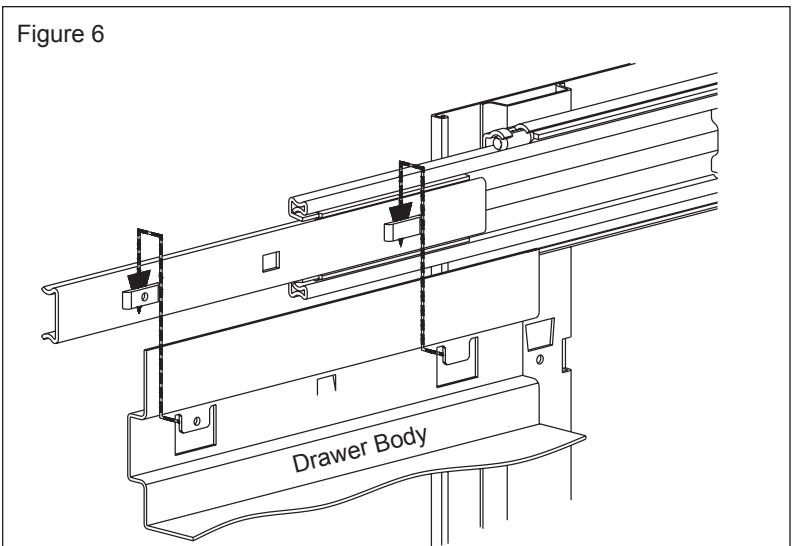
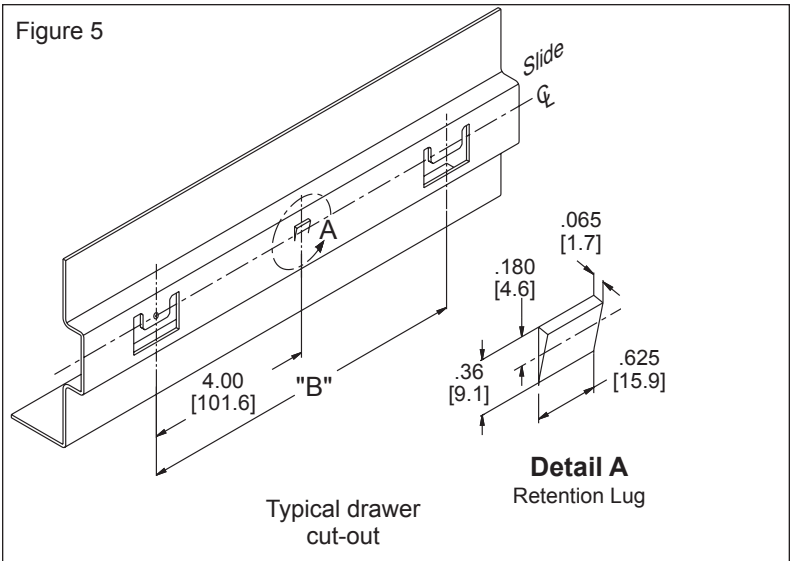

Request Info

1-800-453-1692

www.aboveboardelectronics.com



ACCURIDE INTERNATIONAL INC.

12311 Shoemaker Avenue
 Santa Fe Springs, CA 90670

TEL (562) 903-0200
 FAX (562) 903-0208
www.accuride.com

Manufacturing, Engineering, and Sales
 United States • Germany • Japan • Mexico • United Kingdom • China

Copyright © 2009 Accuride International Inc. 3700-9475(1126)-MK104-R2-0317