

Accuride

MODEL 3620

APPLICATIONS: Suitable for wider drawers; over travel provides full access to contents.

Bayonet and Pocket Mount
1" over travel
Up to 200 lb. [91 kg.] Capacity*

INCHES
mm

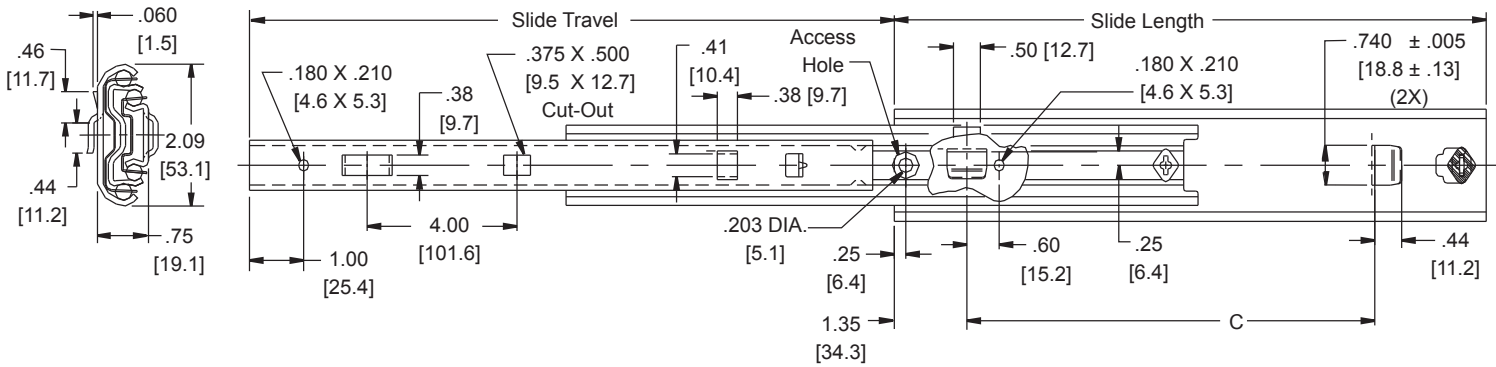
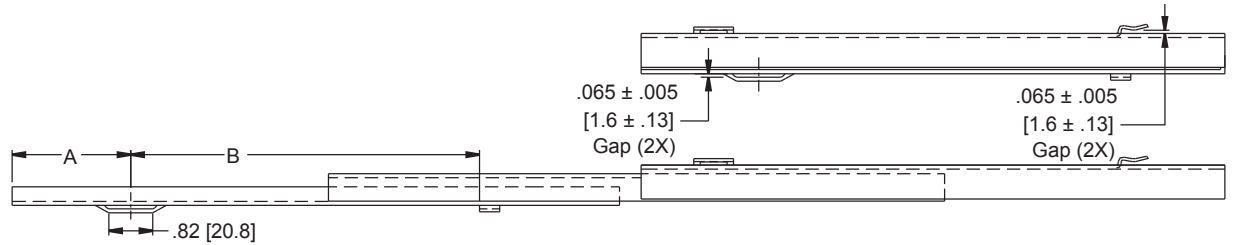

- Finish** Bright electro-zinc (C) plating*
- Length** 14"-28" [356 mm-711 mm]
- Travel** 1" [25.4 mm] over travel
- Height** 2.09" [53.1 mm]
- Load** 200 lbs. [91 kg.]*
- Side Space** .75" [19.1 mm]**
- Drawer Width** Maximum 42" wide
- Mounting** Pocket and bayonet
- Disconnect** Non-disconnect
- Hardware** Not included. Recommended: #8 pan head self-tapping screw
- Features** Hold-in detent
Silenced open and closed

Part Number	Slide Length	Slide Travel	A	B	C
3620-14	14.00 [356]	15.00 [381]	2.30 [58.4]	9.50 [241.3]	9.50 [241.3]
3620-16	16.00 [406]	17.00 [432]	2.30 [58.4]	9.50 [241.3]	12.50 [317.5]
3620-18	18.00 [457]	19.00 [483]	2.80 [71.1]	12.50 [317.5]	12.50 [317.5]
3620-20	20.00 [508]	21.00 [533]	2.30 [58.4]	15.50 [393.7]	15.50 [393.7]
3620-22	22.00 [559]	23.00 [584]	3.30 [83.8]	15.50 [393.7]	15.50 [393.7]
3620-24	24.00 [610]	25.00 [635]	4.30 [109.2]	15.50 [393.7]	15.50 [393.7]
3620-26	26.00 [660]	27.00 [686]	5.30 [134.6]	15.50 [393.7]	15.50 [393.7]
3620-28	28.00 [711]	29.00 [737]	6.30 [160.0]	15.50 [393.7]	15.50 [393.7]

** Provide + .030/- .000 [+ .76 mm/.00 mm] tolerance in cabinet design



Request Info
⚙️ 📄 🌐

1-800-453-1692

www.aboveboardelectronics.com

- * Load rating based on an 18" slide on a 42" wide drawer cycled 50,000 times.
- RoHS Compliant

Cabinet Cut-Out Recommendations

See figure 1 for hat section cut-out details.

Front and rear hat sections are identical.

Attach the hat sections to the cabinet sidewall using the pitch pattern recommended in figure 2.

For C dimensions, see table on front page.

NOTE: Minimum recommended material thickness for hat section is .060" [1.52 mm] or 16 gauge.

Set back=thickness of inset drawer front where applicable +.12" [3.1 mm] clearance.

Mounting Slide to Cabinet

1. Insert the cabinet member rear bayonet tab into the rear hat section cut-out (see figure 3).
2. Lower the slide until the front bayonet tab engages the front cut-out.
3. Insert the front tab into the trapezoidal cut-out. Push firmly downward until the tab snaps into place and the retention lug is engaged (see figure 3).
4. The retention lug prevents the cabinet member from lifting and disengaging from the cabinet.
5. Repeat procedure on opposite side of cabinet for the companion slide.

Drawer Cut-Out Recommendations

See figure 4 for drawer cut-out details.

For B dimension (figure 5) see table on front page. For optimum slide performance, it is recommended that the slide centerline be located at the centerline of the drawer side or slightly toward the plane of the drawer pull.

Cut-out recommendation is based on 16-gauge material.

If a thinner material is used, adjustment to the cut-outs must be made to ensure a proper fit. Refer to the table below for the recommended modifications.

Gauge	Material Thickness	Dimension D	Dimension E
16	.060 [1.52]	.855 [21.7]	.395 [10.0]
18	.048 [1.22]	.865 [22.0]	.405 [10.3]
20	.036 [.91]	.885 [22.5]	.425 [10.8]
22	.030 [.76]	.905 [23.0]	.435 [11.1]

* For dimension B, see tabulated table on page one.

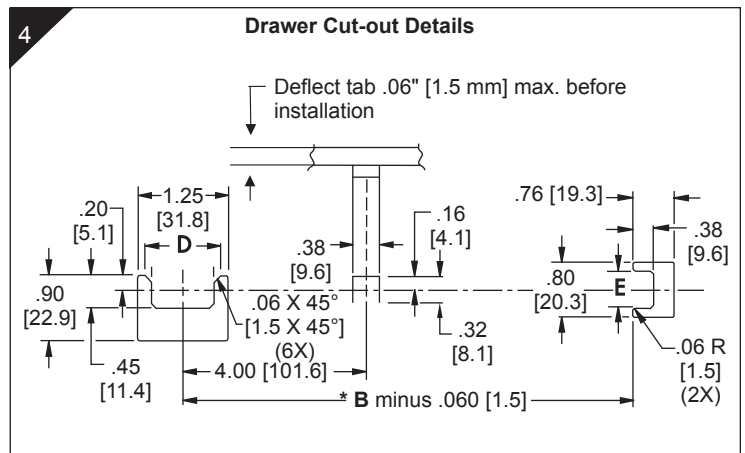
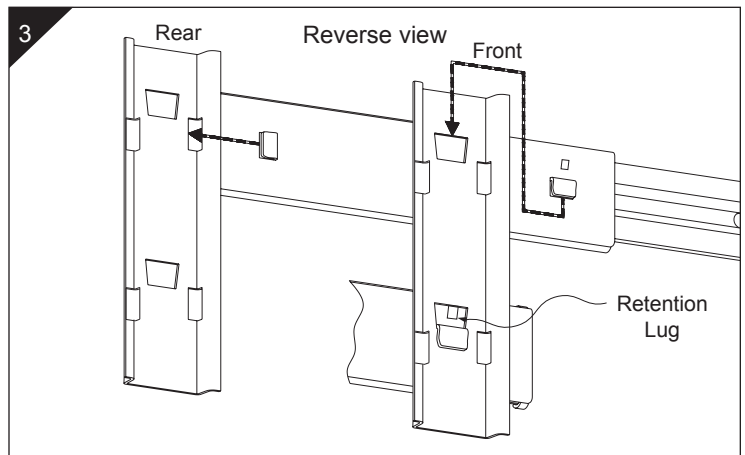
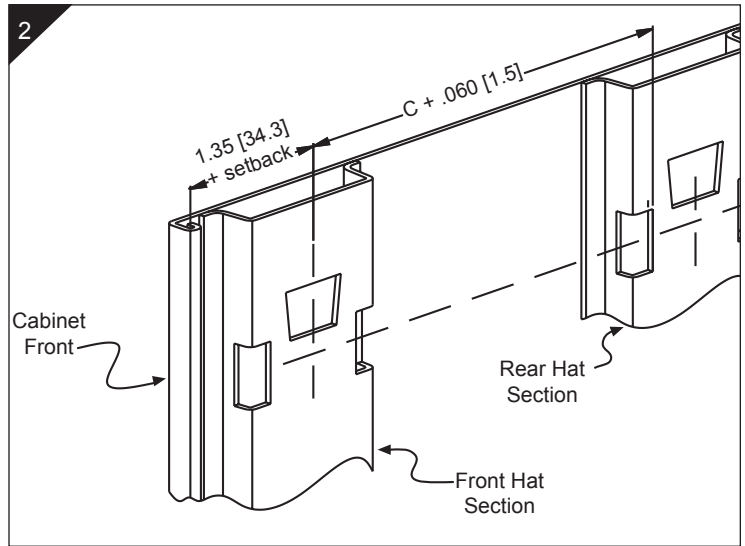
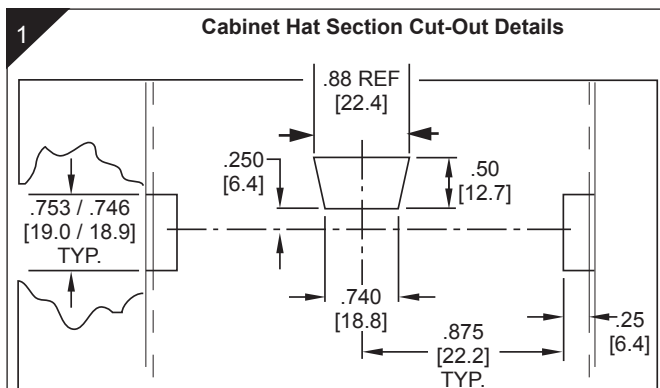

Mounting Slide to Drawer

1. Using recommended placement of drawer bayonets (figure 5), extend both right and left hand drawer members.
2. Position rear drawer tabs into both rear slide pockets. Guide front tabs into front pockets and push firmly into place making sure the retention lug snaps into the cut-out on the drawer member.
3. The drawer retention lug will adequately protect the drawer from lifting and disengaging from the slide.

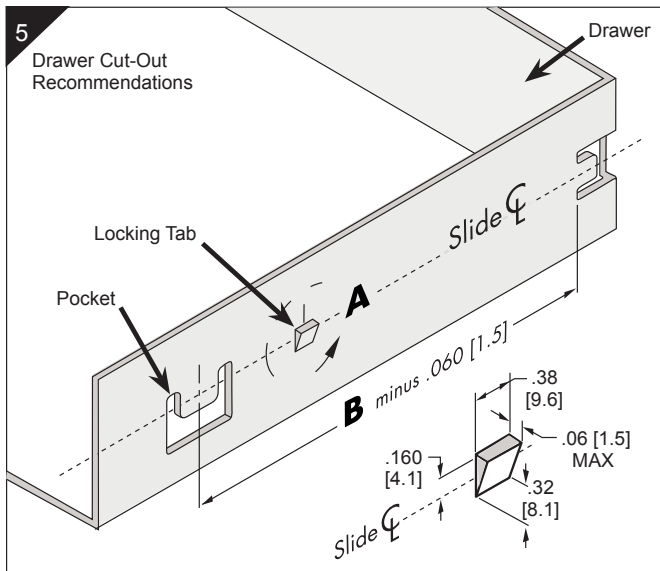

Slide Ordering Instructions

Complete your slide order by specifying the following:

Model 3620 Slide

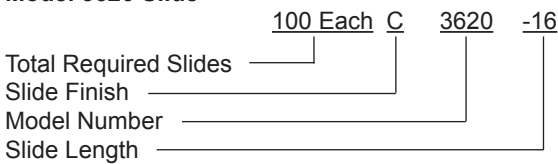

Packaging

Bulk packaging only. D-pack not available. Slides packaged in boxes (no polybags); left and right hand slides boxed separately.

Lengths are packaged:

- 14"-20" 14 each per box.
- 22"-28" 10 each per box.

Specifications

Slide members: Cold-rolled steel

Ball bearings: Carburized steel

RoHS compliant

Note: Specifications, materials, prices, terms, and delivery are subject to change without notice.



ACCURIDE INTERNATIONAL INC.

12311 Shoemaker Avenue
Santa Fe Springs, CA 90670

TEL (562) 903-0200
FAX (562) 903-0208
www accuride.com

Manufacturing, Engineering, and Sales
United States • Germany • Japan • Mexico • United Kingdom • China

Copyright © 2009 Accuride International Inc. 3700-9528(1216)-MK134-N-1109